

FEATURES

- ' High capacity squirrel cage blower is designed for quiet operation with flexible duct systems.
- ' Standard flexible duct connector installed on the unit. This connect also adapts to Aqua-Air AT series adapter duct tees.
- ' Three way motorized water valve is pre-installed on the unit. A separate valve assembly is not necessary.
- ' Dual condensate outlets on the drain pan are factory connected into a common 1/2" hose barb tee for ease of installation.
- ' Vertically adjustable mounting legs with rubber vibration pads and mounting screws.
- ' The air bleeder is mounted on the end of a 12" plastic tube for easy access during commissioning of the system.
- ' All surfaces that might have condensate form on them are covered in 1/8" thick foam insulation.
- ' Units available for 115/1/60, 100/1/50, 208-230/1/60 and 200-220/1/50 power inputs.
- ' Aqua-Air BH series blower heaters bolt directly to the discharge of the blower.

SPECIFICATIONS		AQOW-05		AQOW-07		AQOW-10	
COOLING CAPACITY		5,000 BTU/HR 1,260 KCAL/HR		7,000 BTU/HR 1765 KCAL/HR		10,000 BTU/HR 2,520 KCAL/HR	
AIR FLOW CAPACITY		135 CFM	230 M³H	270 CFM	460 M³H	330 CFM	560 M³H
WEIGHT		14 LBS	6.4 KG	17 LBS	7.7 KG	26 LBS	11.8 KG
WIDTH	A	15-1/8"	384mm	14-1/2"	368mm	16"	406mm
LENGTH	B	13-3/8"	340mm	14-1/2"	368mm	14-3/8"	365mm
HEIGHT	C	12"	305mm	12-7/8"	327mm	14-1/4"	362mm
AIR DISCHARGE	D	7-3/4"	197mm	8-7/8"	225mm	8-1/2"	216mm
CENTER LINE	E	2-3/4"	70mm	2-7/8"	73mm	2-7/8"	73mm
AMP DRAW 115 / 230		2.0	1.0	2.0	1.0	3.0	1.5
POWER, WATTS		127		127		190	
MIN RETURN AIR		64 in²	413 cm²	72 in²	465 cm²	100 in²	645cm²
MIN SUPPLY AIR		32 in²	207 cm²	40 in²	258 cm²	48 in²	310 cm²
CHILLWATER IN / OUT		5/8"	16mm	5/8"	16mm	5/8"	16mm
FLEX DUCT COLLAR		4"	102mm	5"	127mm	5"	127mm
MAXIMUM HEATER		1 Kw		1.5 Kw		1.5Kw	

ADD "C" TO THE END OF THE MODEL NUMBER FOR A 208-230/1/60 UNIT, "CK" FOR A 200-220/1/50 UNIT

80935.WPD

AQUA-AIR MANUFACTURING, division of the James D. Nall Co., Inc.
1050 East 9th Street, Hialeah, Florida 33010 U.S.A.
Ph. 305-884-8363 Fax 305-883-8549 Email sales@aquair.com

REVISION BLOCK

REV.	DESCRIPTION	REV. BY	DATE
B	MODIFIED DRAIN PAN	YP	09-18-96

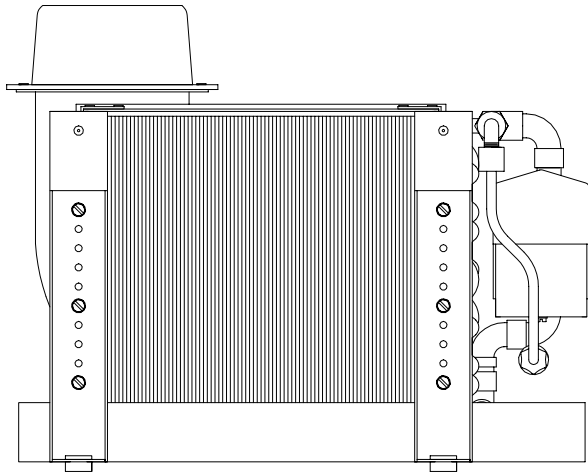

FRONT

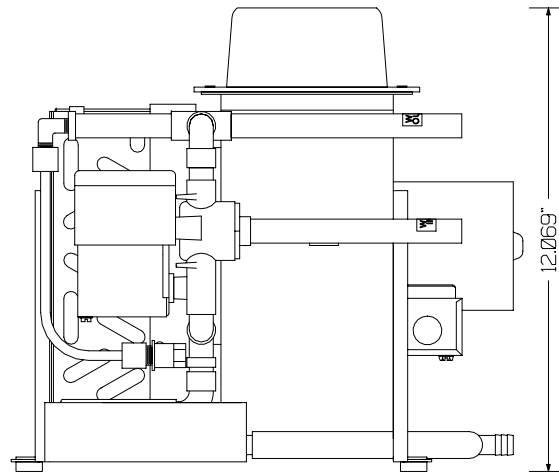

RIGHT

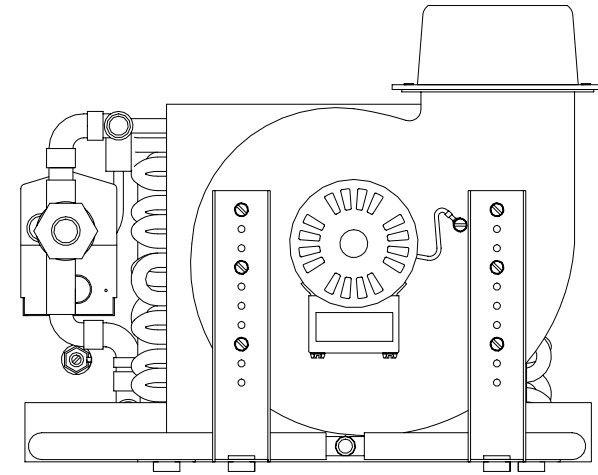

BACK

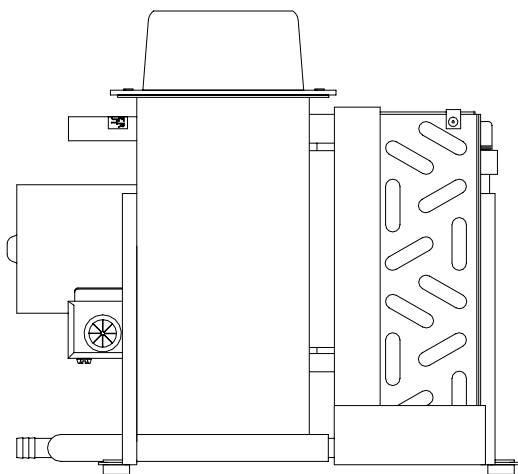

LEFT

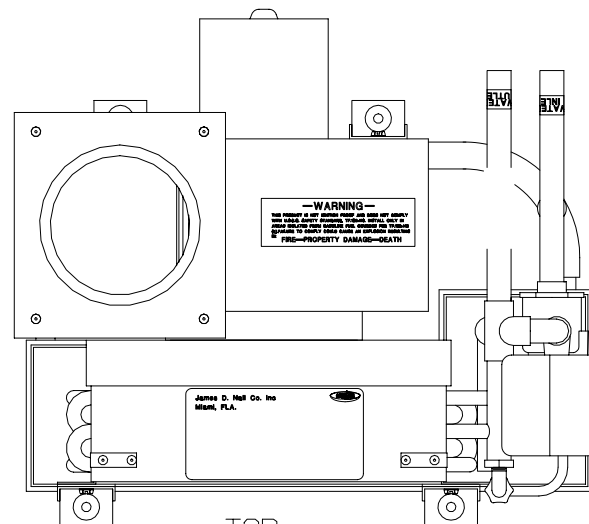

TOP

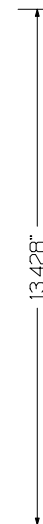

AQUA AIR MFG			
AQOW-05			
DRWG NUMBER	AQOW-05	DRWN BY	CP
SCALE	NONE	DATE	10-20-94
APPROVED BY		REVISION DATE	9-18-96
			REV B

REVISION BLOCK

REV.	DESCRIPTION	REV. BY	DATE
B	MODIFIED DRAIN PAN	YP	09-18-96

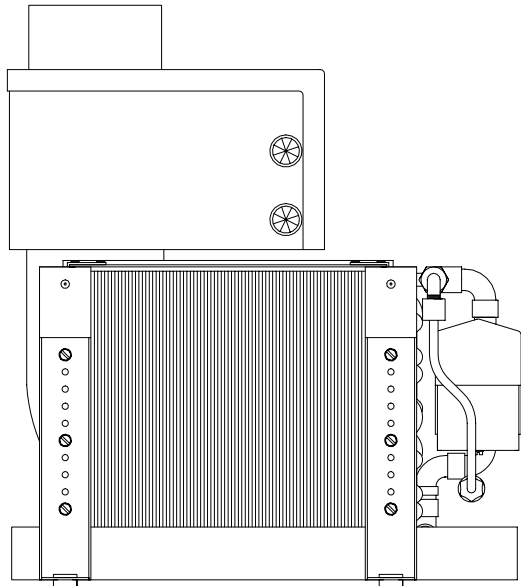

FRONT

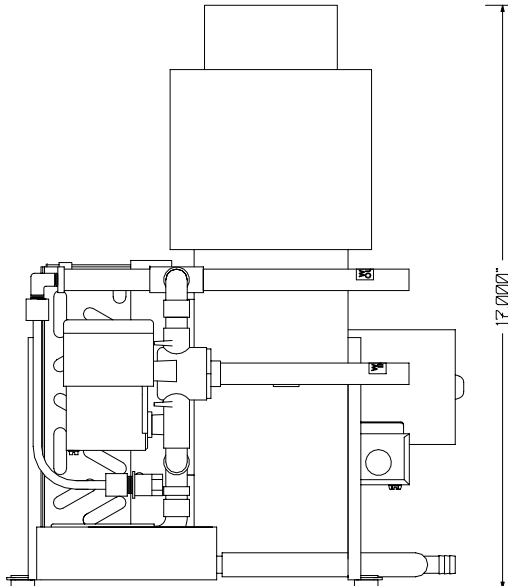

RIGHT

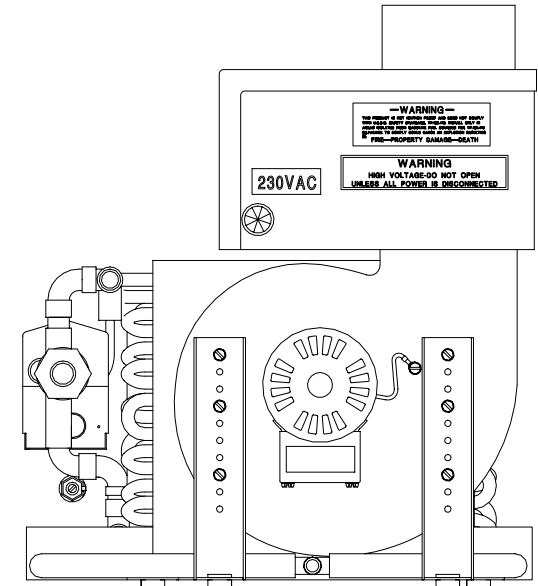

BACK

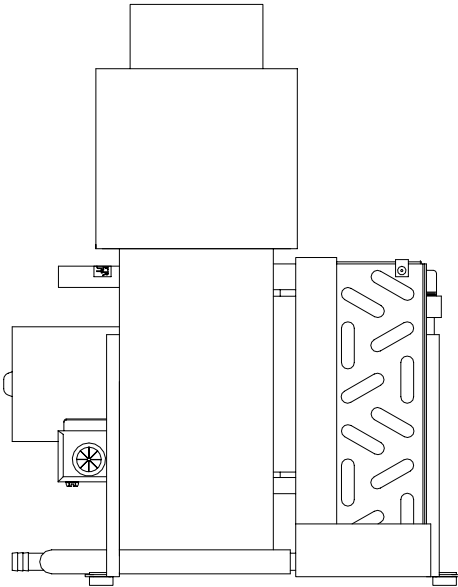

LEFT

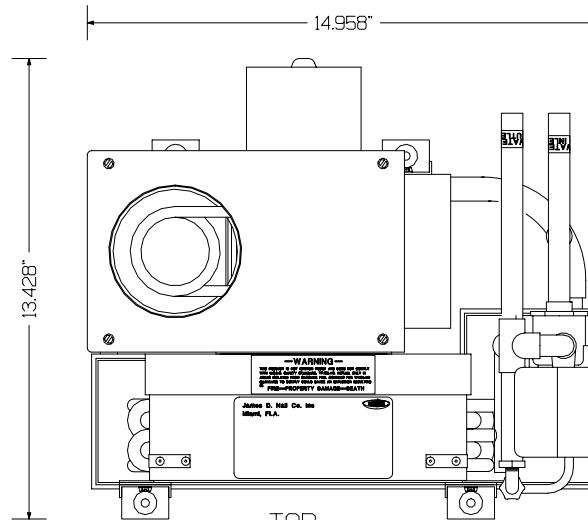

TOP

17.000"

14.958"

13.428"

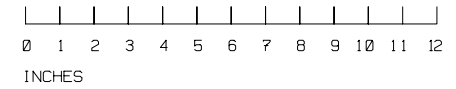

AQUA AIR MFG

AQOW-05 WITH
BLOWER HEATER

ISSUED NUMBER	APPROVED BY	DRAWN BY	DATE
AQOW-05		CP	10-20-94
SCALE	NONE	DESIGN DATE	9-18-96
			REV B

REVISION BLOCK			
REV.	DESCRIPTION	REV. BY	DATE
B	MODIFIED DRAIN PAN	YP	09-18-96

14.491"

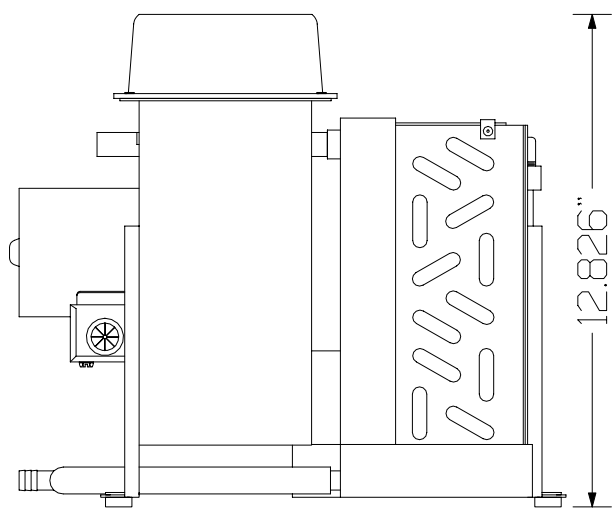

LEFT

12.826"

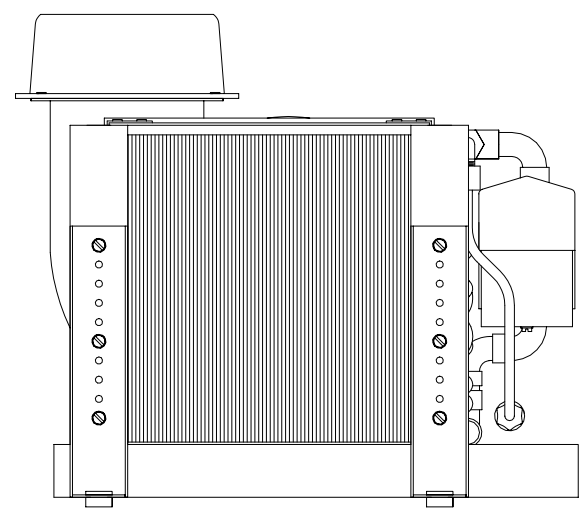

FRONT

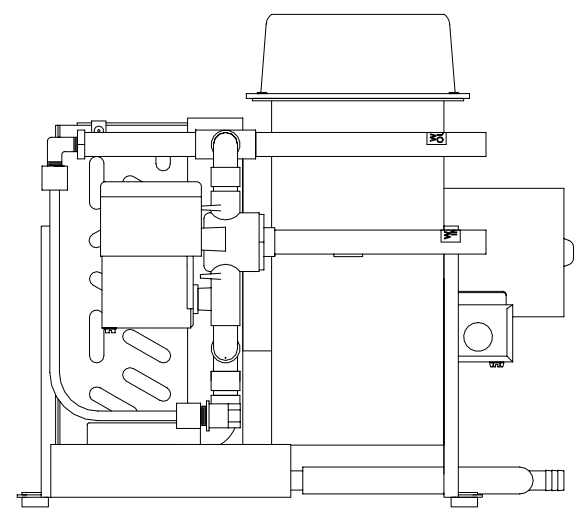

RIGHT

14.781"

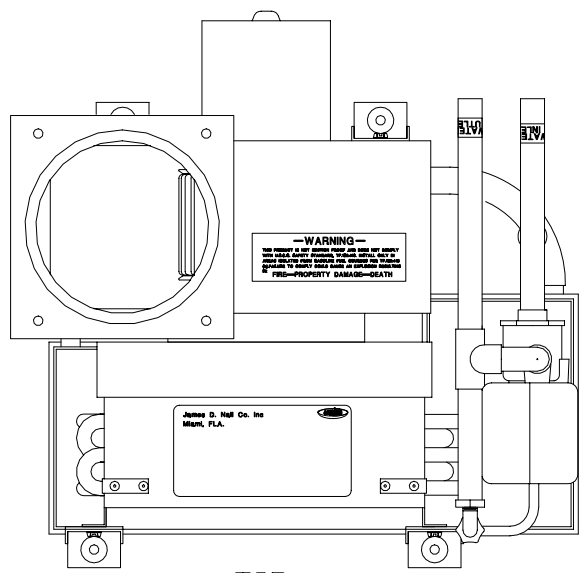

TOP

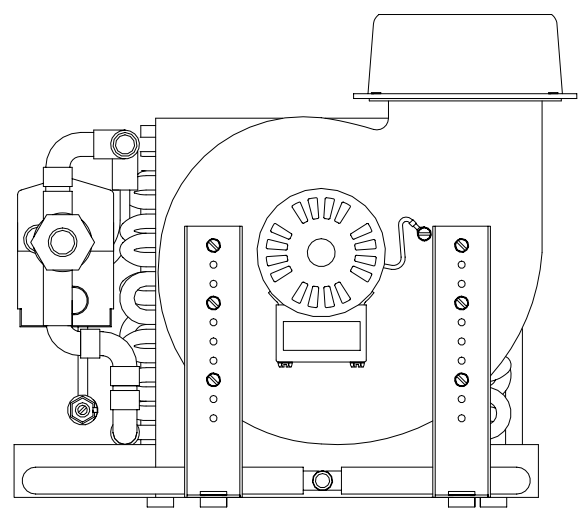

BACK

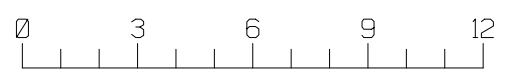

SCALE - INCHES

AQUA AIR MFG			
AQOW-07			
DRAWING NUMBER	AWOW-07	DRAWN BY	CP
SCALE	NONE	DATE	10-24-94
APPROVED BY		REVISION DATE	9-18-96
		REV	B

14.491"
8-7/8"

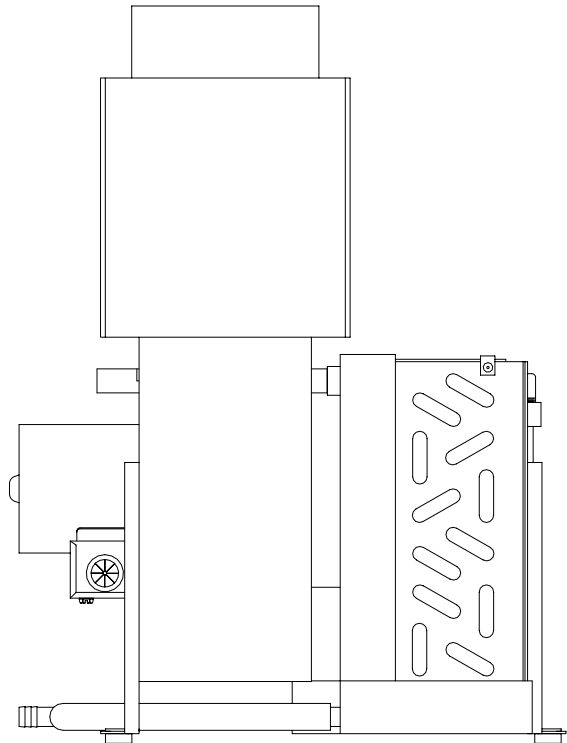

LEFT

14.875"
12"

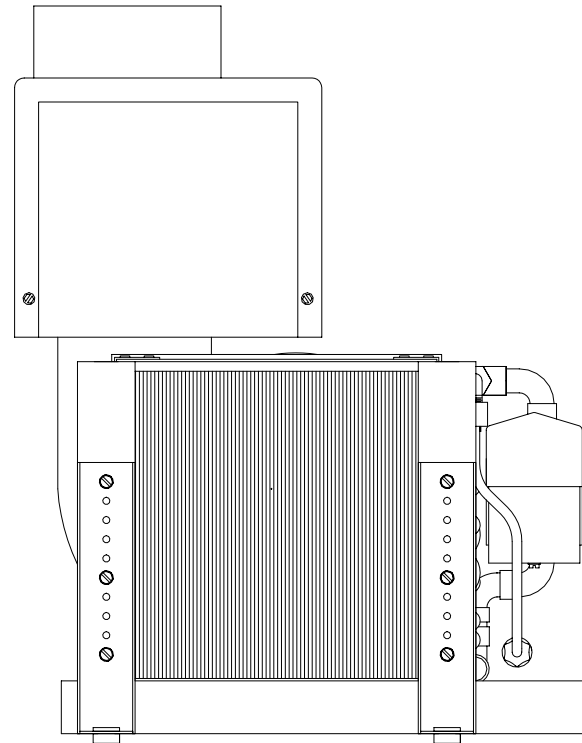

FRONT

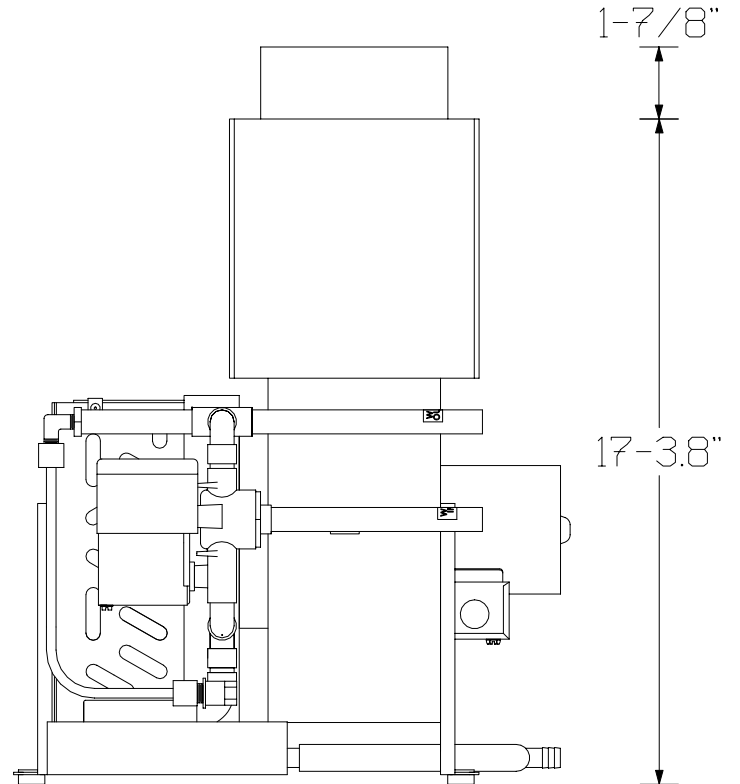

RIGHT

1-7/8"

17-3.8"

5" HOSE ADAPTER

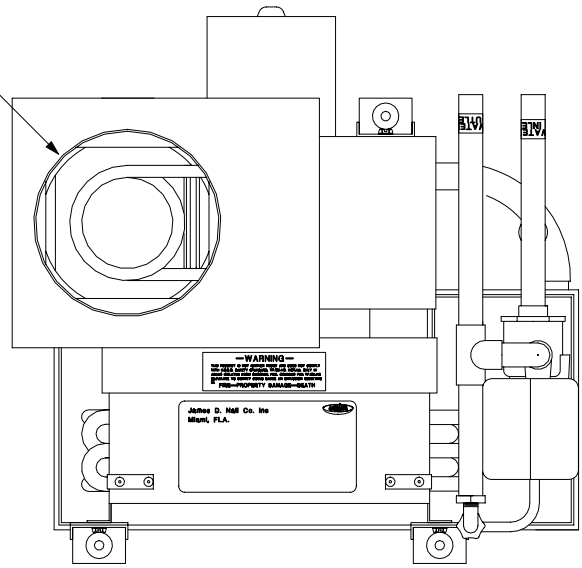

TOP

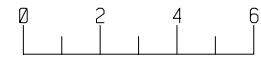

SCALE - INCHES



SCALE - MILLIMETERS

REVISION BLOCK			
REV.	DESCRIPTION	REV. BY	DATE
B	MODIFIED DRAIN PAN	YP	09-18-96

AQUA AIR MFG			
AQOW-07 WITH BLOWER HEATER			
CHANGED NUMBER	AQOW-07	DRAWN BY	CP
DATE	11-14-95	APPROVED BY	
SCALE	NONE	DATE	9-18-96
REV	B		

REVISION BLOCK

REV.	DESCRIPTION	REV. BY	DATE
B	MODIFIED DRAIN PAN	YP	09-18-96

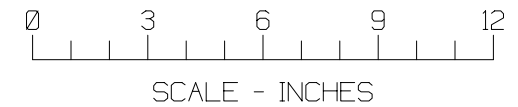
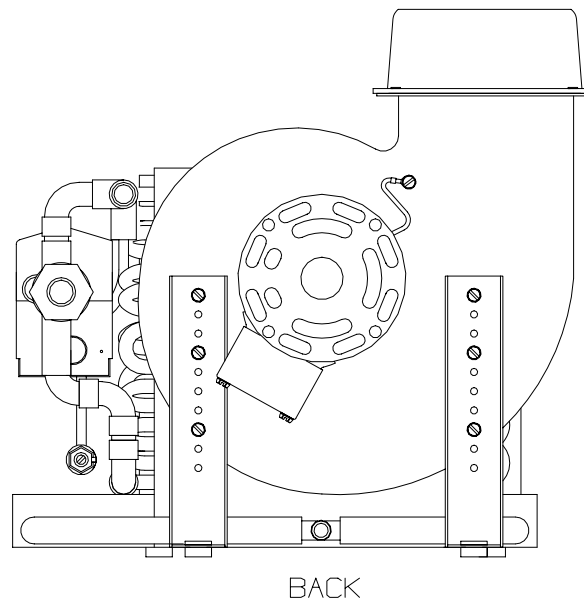
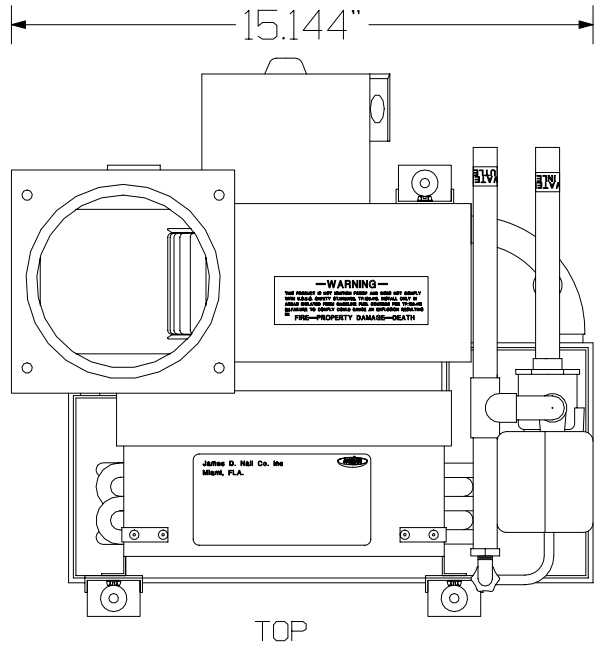
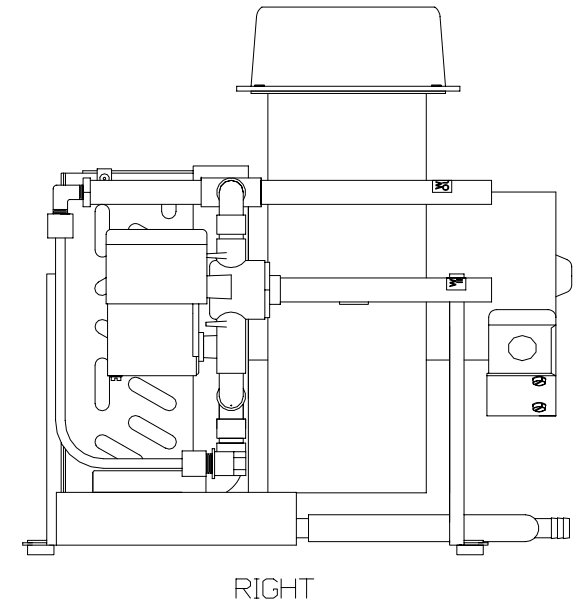
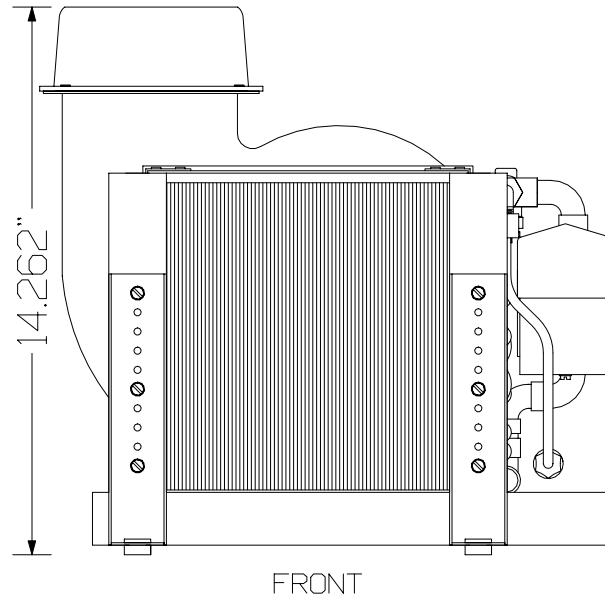
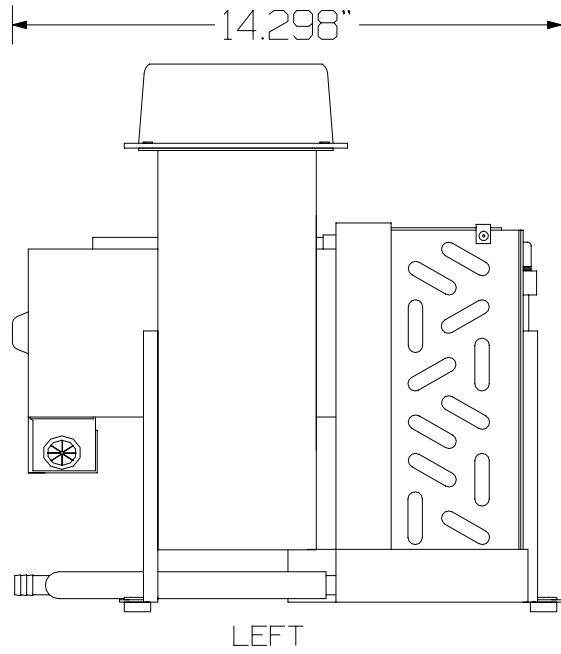

AQUA AIR MFG			
AQOW-07CK			
DESIGNED BY	AWQW-07	DRAWN BY	CP
DATE	10-24-94	APPROVED BY	
SCALE	NONE	REVISION DATE	9-18-96
			REV B

REVISION BLOCK

REV.	DESCRIPTION	REV. BY	DATE
B	MODIFIED DRAIN PAN	YP	09-18-96

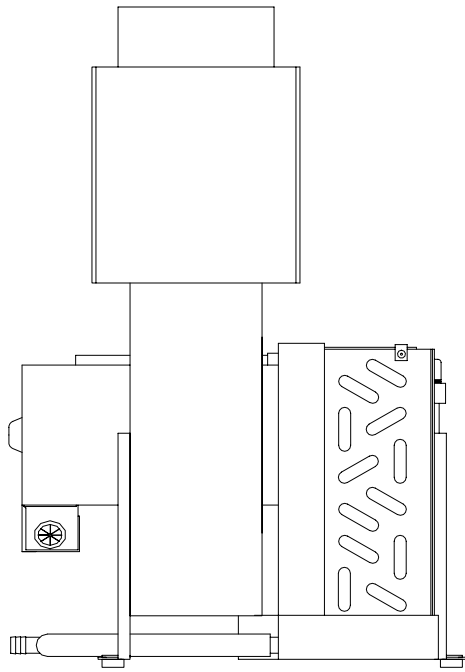

LEFT

13.888"

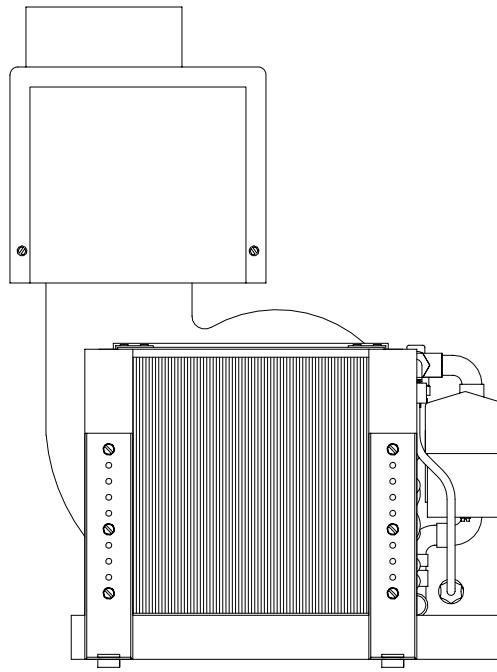

FRONT

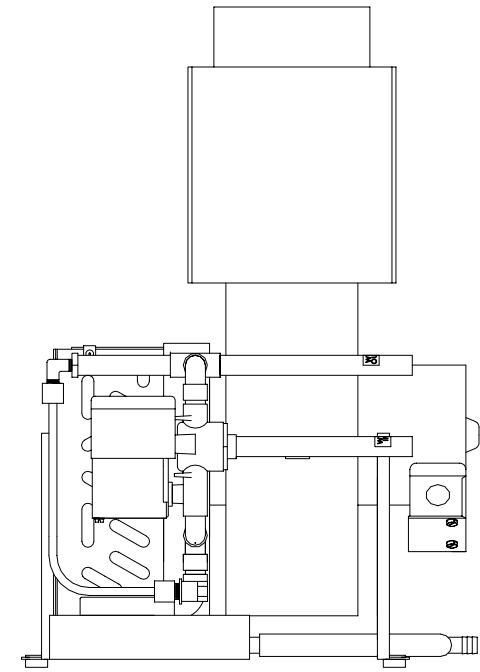

RIGHT

15.238"

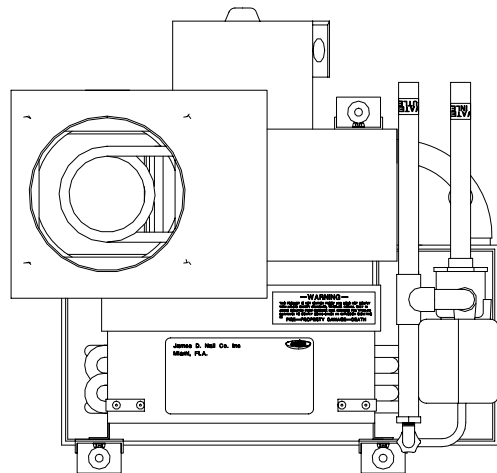

TOP

20.629"

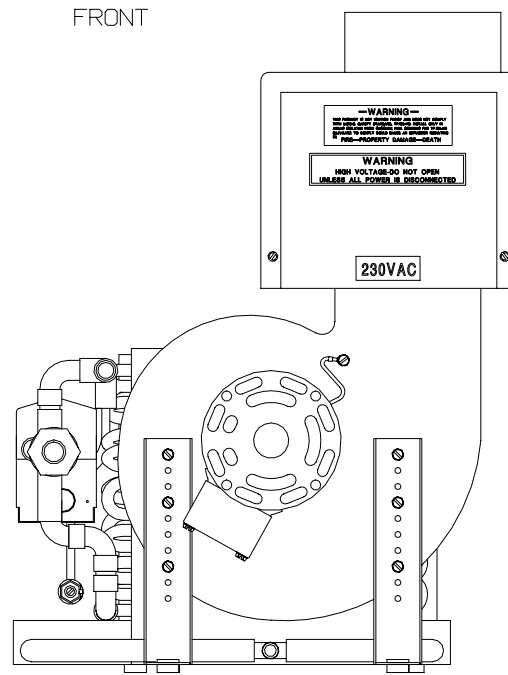

BACK

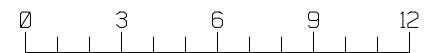

SCALE - INCHES

AQUA AIR MFG

AQOW-07CK WITH
BLOWER HEATER

DESIGN	DATE	REV
AQOW-07	10-24-94	CP
SCALE	APPROVED BY	REVISION DATE
NONE		9-18-96

REV B

REVISION BLOCK

REV.	DESCRIPTION	REV. BY	DATE
B	MODIFIED DRAIN PAN	YP	09-18-96

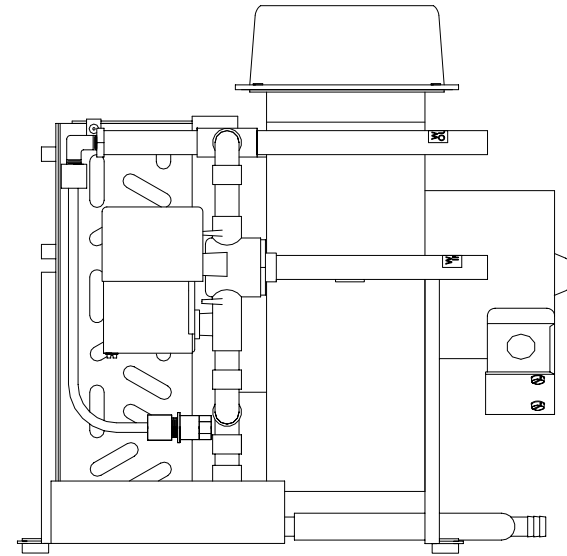
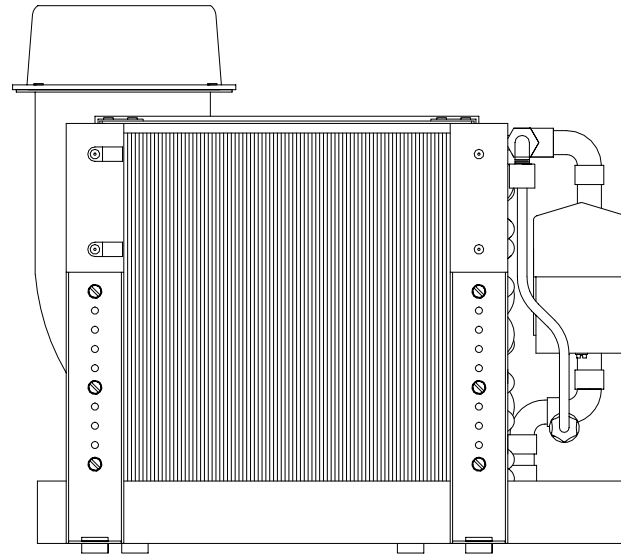
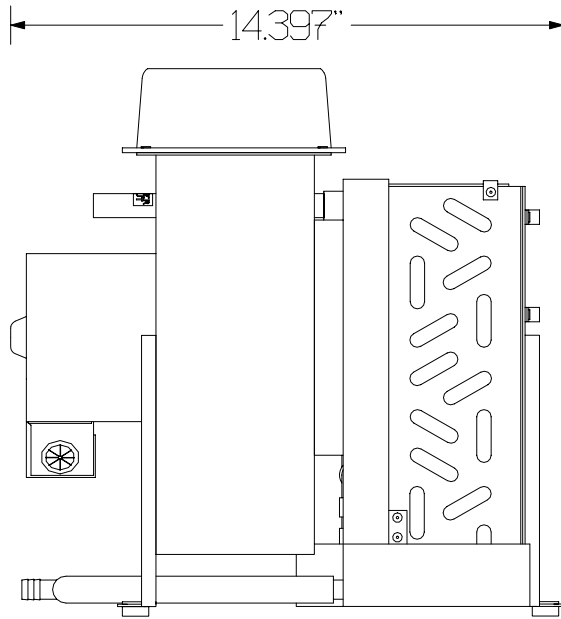

LEFT

FRONT

RIGHT

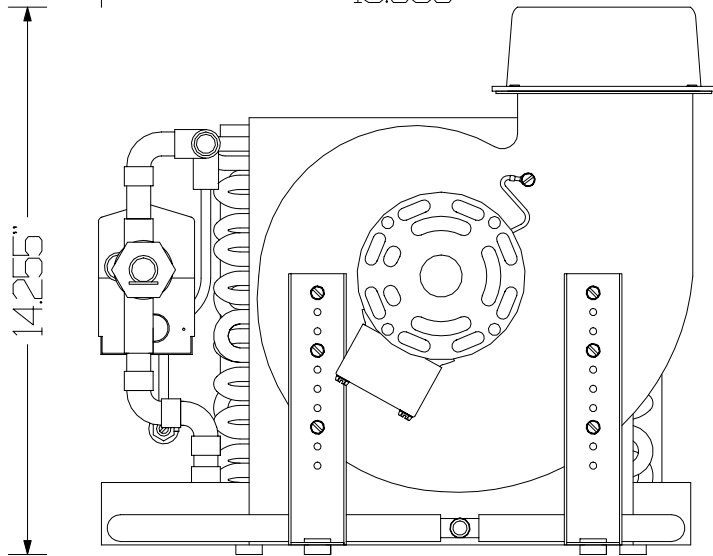

BACK

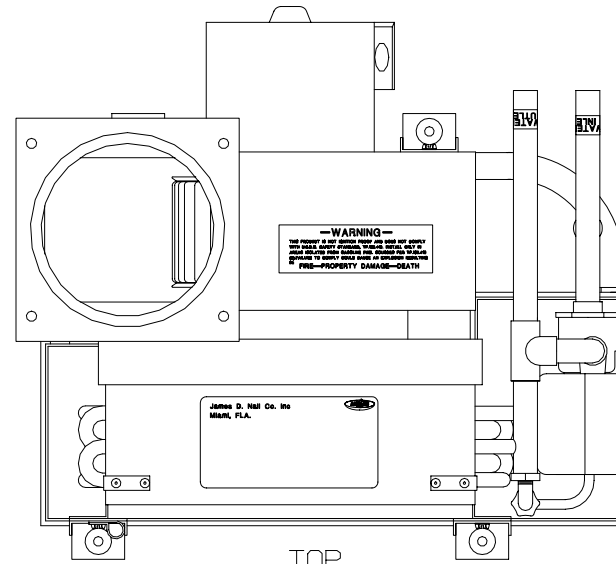

TOP

SCALE : INCHES

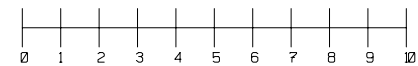

AQUA AIR MFG

AQOW-10

DRAWING NUMBER	CP	DATE	10-28-94
SCALE	NONE	REVISION DATE	9-18-96

APPROVED BY	REV	B
-------------	-----	---

REVISION BLOCK			
REV.	DESCRIPTION	REV. BY	DATE
B	MODIFIED DRAIN PAN	YP	09-18-96

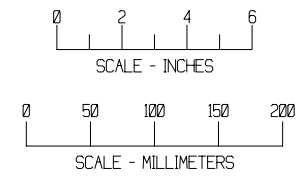
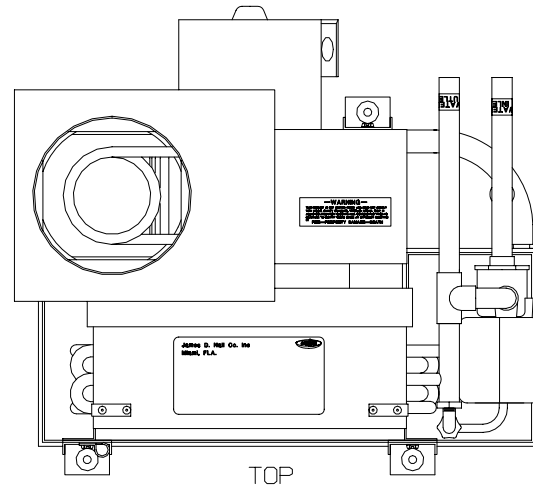
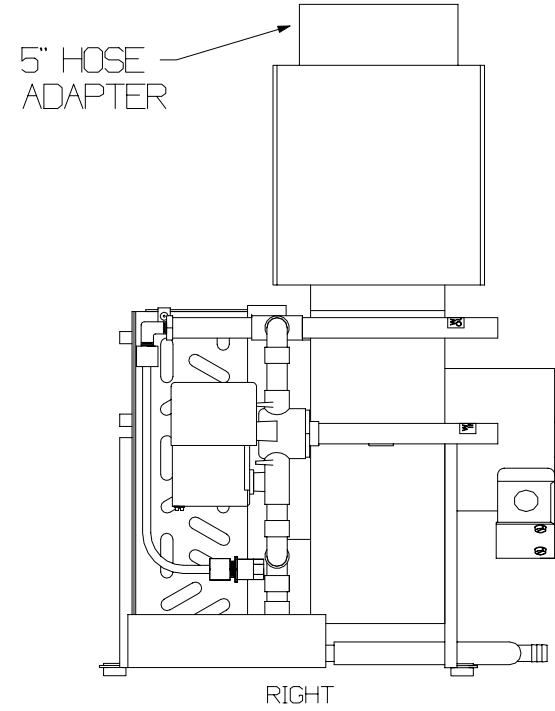
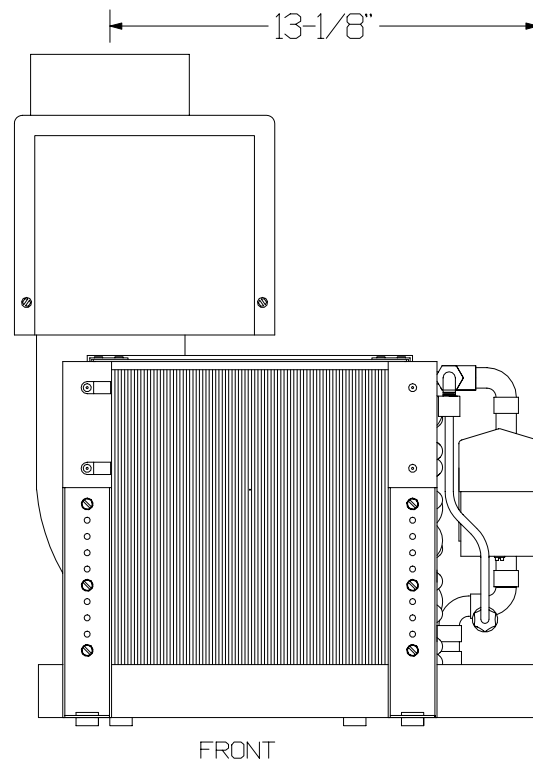
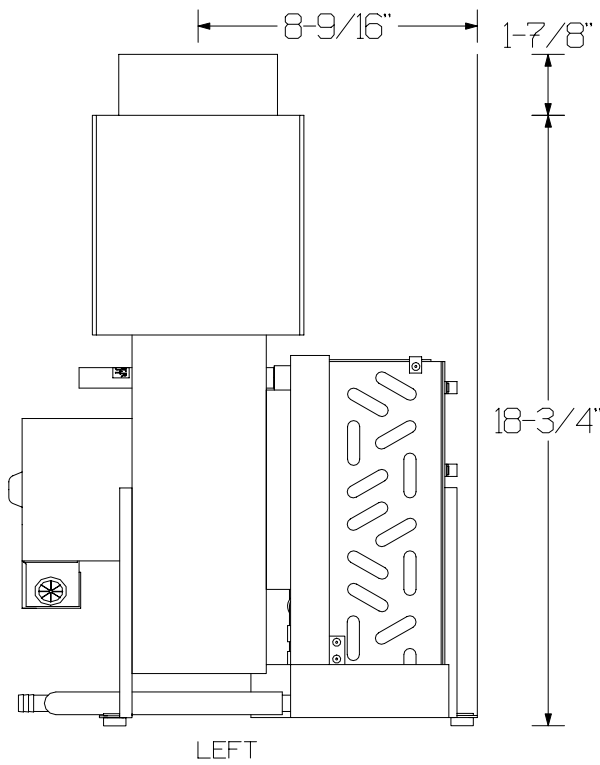

AQUA AIR MFG			
AQOW-10 WITH BLOWER HEATER			
DRAWING NUMBER	BY	DATE	REV
AQOW-10	LES	12-19-95	B
SCALE	APPROVED	DATE	REV
NONE		9-18-96	B

REVISION BLOCK

REV.	DESCRIPTION	REV. BY	DATE
B	MODIFIED DRAIN PAN	YP	09-18-96

16.022"

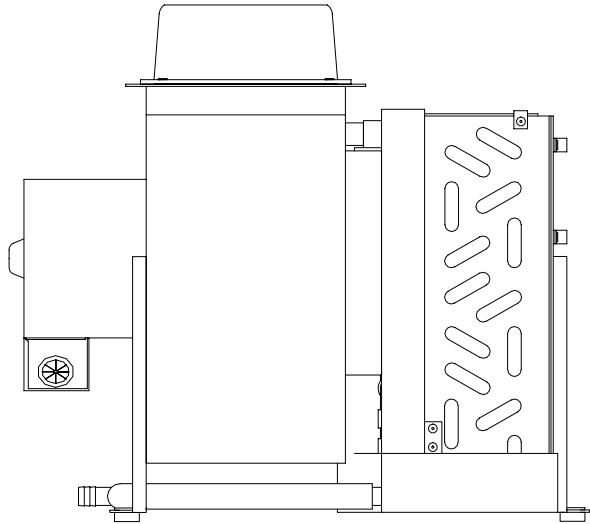

LEFT

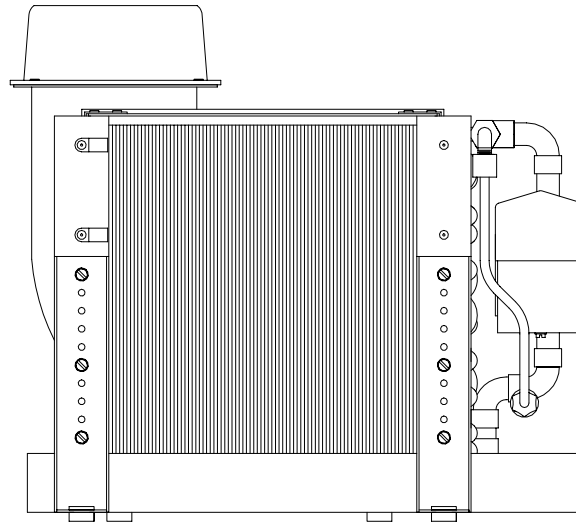

FRONT

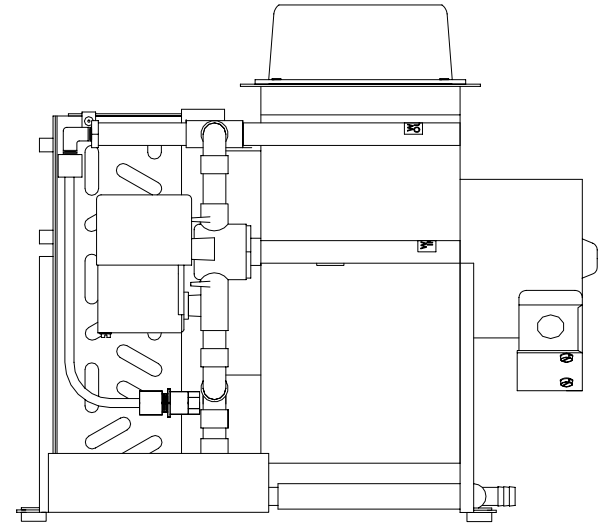

RIGHT

15.892"

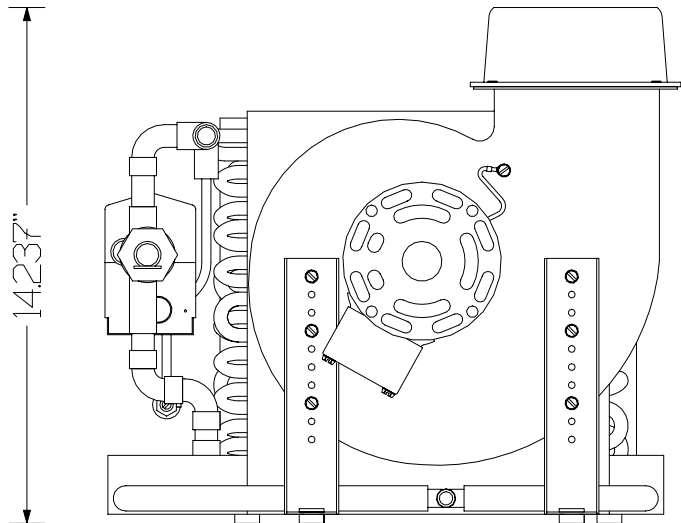

14.237"

BACK

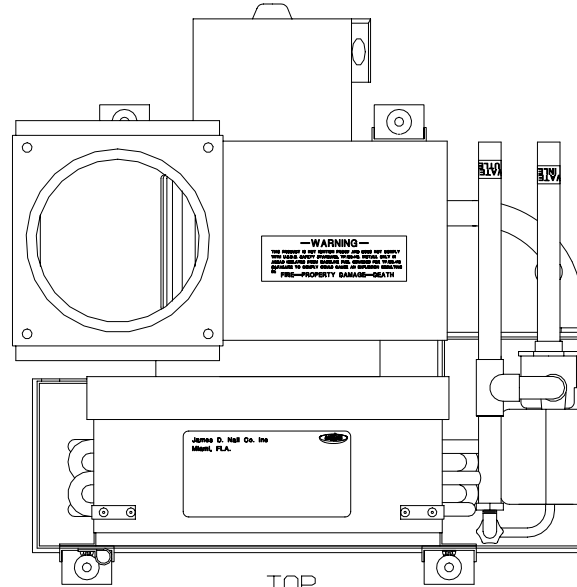

TOP

SCALE : INCHES



AQUA AIR MFG

AQOW-10CK

DRAWING NUMBER	AAOW-10	DRAWN BY	CP	DATE	10-28-94
SCALE	NONE	APPROVED BY		REVISION DATE	9-18-96
					REV B

REVISION BLOCK

REV.	DESCRIPTION	REV. BY	DATE
B	MODIFIED DRAIN PAN	YP	09-18-96

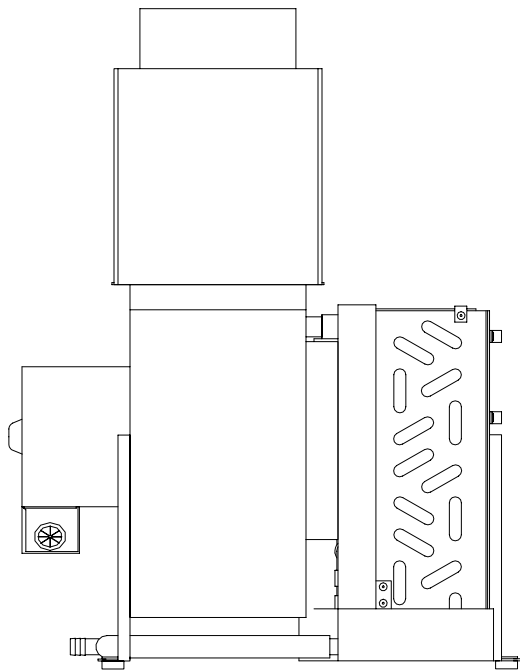

LEFT

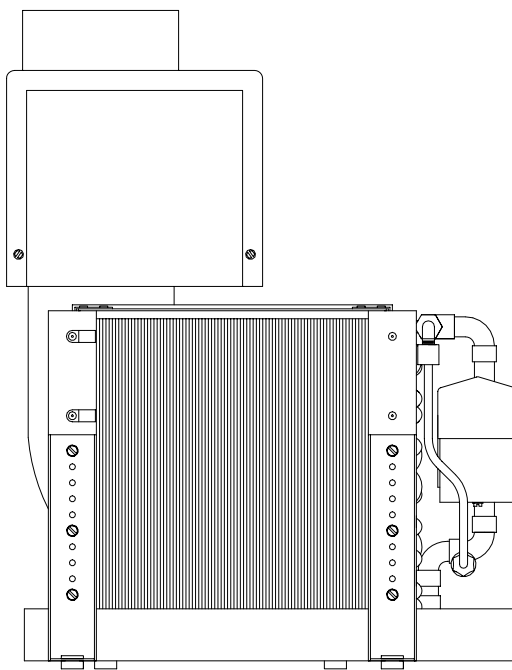

FRONT

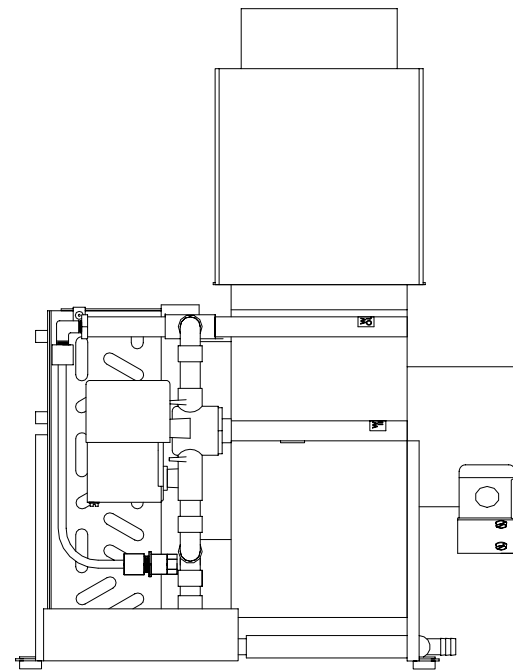

RIGHT

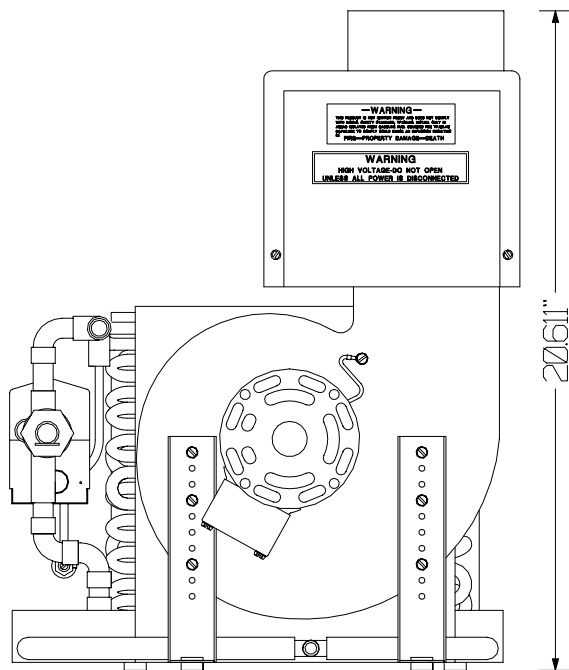

BACK

2061"

16070"

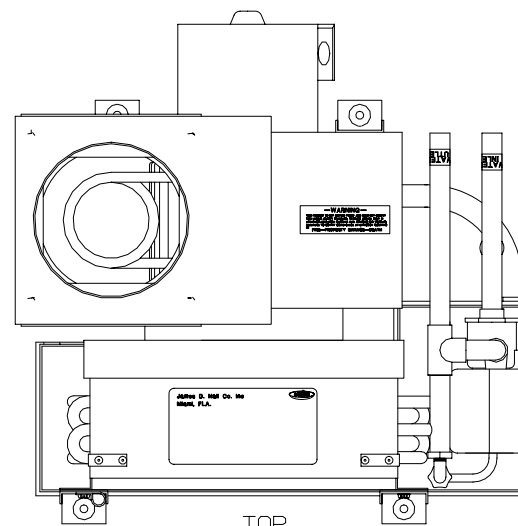

TOP

16022"

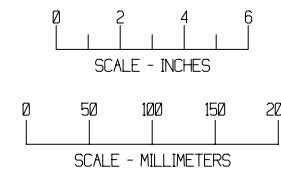

AQUA AIR MFG			
AQOW-10CK WITH BLOWER HEATER			
OWNER	MODEL	DATE	REV
AQOW-10	CP	10-28-94	
SCALE	APPROVED	DATE	REV
NONE		9-18-96	B

WIRING SCHEMATICS

HOT WATER HEATING SYSTEM

MULTIPLE FAN COILS CAN BE CONNECTED IN PARALLEL TO THE THERMOSTAT PROVIDED THEY DO NOT EXCEED THE MAXIMUM AMPERAGE RATINGS OF THE CONTROL MODULE

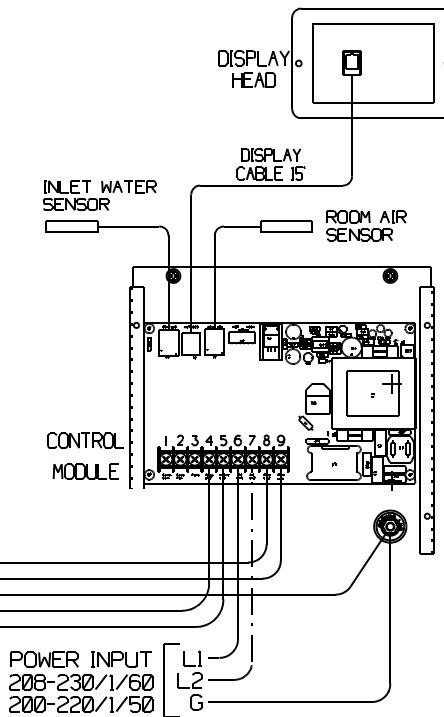
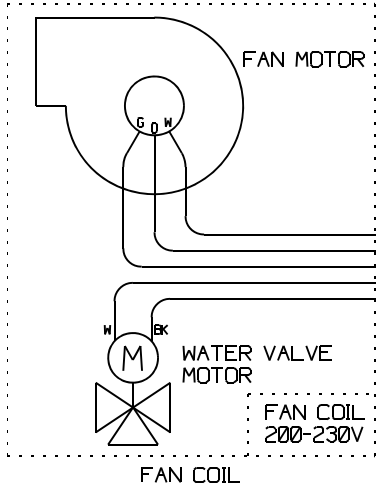

MAXIMUM CIRCUIT RATINGS
WATER VALVE 1/4A
FAN MOTOR 12A
HEATER 12A

TERMINAL BLOCK CONNECTIONS

1. HEATER ELEMENT L1
2. HEATER ELEMENT L2
3. N/A
4. WATER VALVE L2
5. WATER VALVE L1
6. POWER INPUT L1
7. POWER INPUT L2 or N
8. FAN L2
9. FAN L1

80999-SP.GXD

ELECTRIC ELEMENT HEATING SYSTEM

DUCT HEATER (DH SERIES) or
BLOWER HEATER (BH SERIES) or
FAN COIL HEATER (HTS SERIES)
200-230 / 1 / 50-60

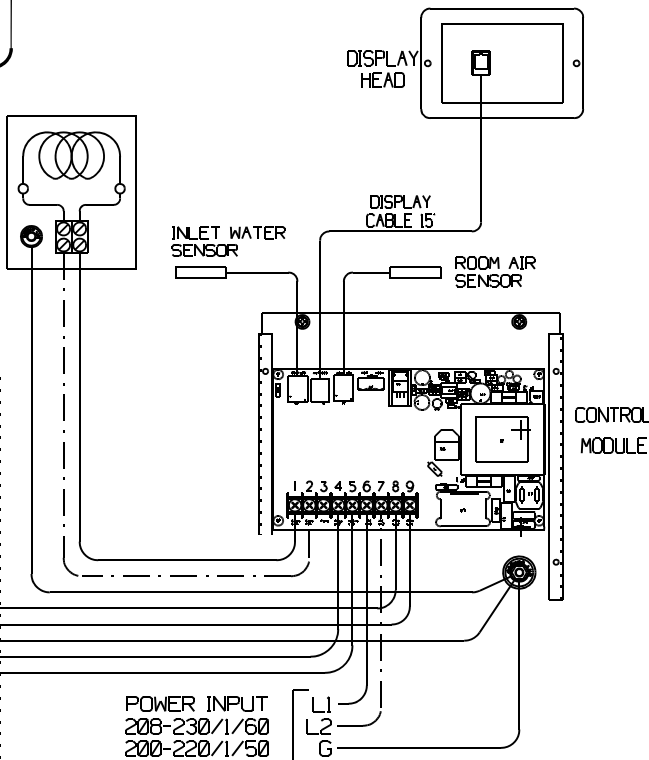
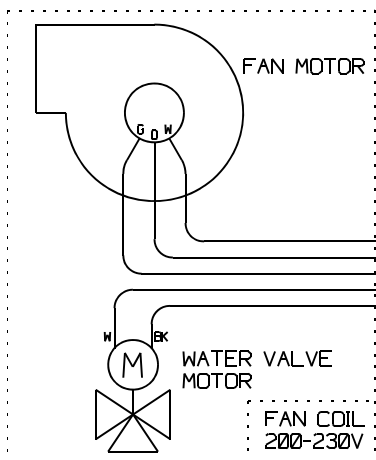

8099P-SP.GXD