

mini-kool series

INSTALLATION, OPERATION & MAINTENANCE

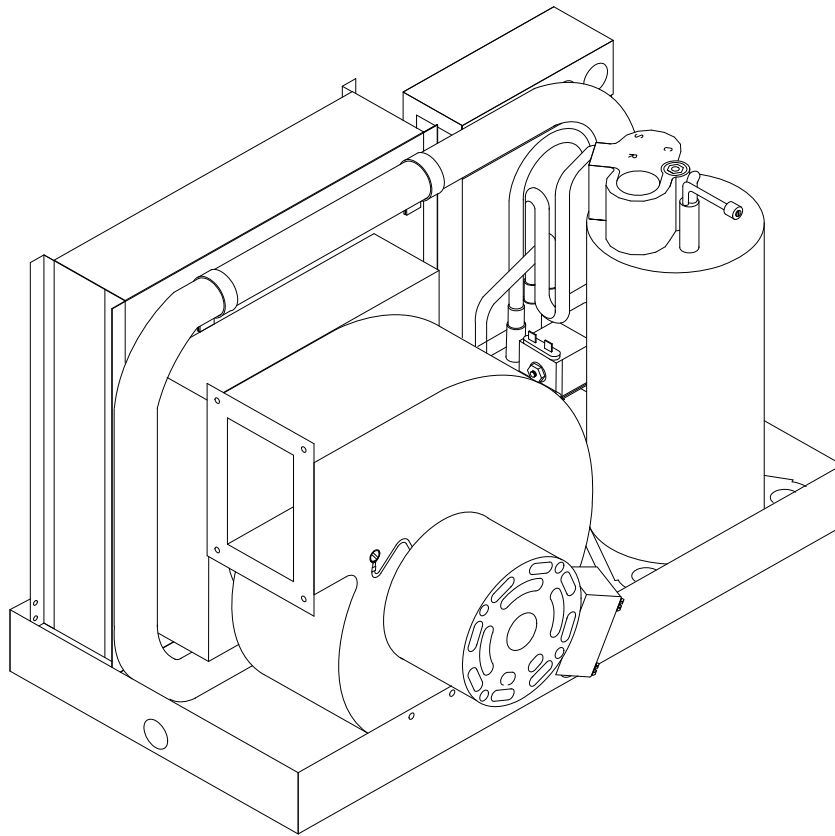

AQUA AIR
**MARINE AIR CONDITIONING
SYSTEMS**

80806-1 rev 04/09

TABLE OF CONTENTS

INTRODUCTION.....	1
PRODUCT OVERVIEW.....	1
The <i>mini-kool</i> [®] self contained unit.....	1
Thermostat / Controllers.....	3
Seawater pump.....	4
Pump relay.....	4
Seawater kit.....	5
Duct / Grille kit.....	5
INSTALLATION OF BASIC COMPONENTS	
The self contained unit.....	7
Blower rotation and collar.....	8
Insulated flex duct.....	8
Grilles.....	8
Return air filter.....	9
Seawater hoses.....	9
Thermostat / Controllers.....	9
Seawater pumps.....	10
Electrical connections.....	11
SYSTEM START-UP.....	
Pre-Start-Up check list	12
Start-up with TSV digital control.....	13
Start-up with mechanical controls.....	14
MAINTENANCE.....	15
TROUBLESHOOTING.....	16
IMPORTANT SAFETY NOTICES.....	19
MANUFACTURERS WARRANTY.....	20
OWNERS INFORMATION.....	21
TSV CONTROL OPERATIONS.....	22
CONTROL TEMPLATES.....	46
WIRING DIAGRAMS.....	47

INTRODUCTION

Thank you for purchasing the Aqua-Air® *mini-kool*® Self Contained Marine Air Conditioning System. Your new system is the most technically advanced system available, and it has been designed and manufactured by Aqua-Air®, division of the James D. Nall Co., the oldest company in the marine air conditioning industry. As the technology leader, Aqua-Air® has the experience and technical resources to continually develop and produce the innovations that result in better quality, more efficient and more cost effective marine air conditioning products. Your new *mini-kool*® is just one example.

The *mini-kool*® unit has been specifically designed for use in the marine environment. The configuration and all the materials and components that go into the manufacture of this unit are extensively tested for efficiency and durability in this sometimes harsh environment. With proper installation, operation and maintenance, your new *mini-kool*® system should give you years of trouble free comfort on board your boat.

This manual will inform you of the different components that comprise the system and provide the basic information that you will need to correctly install a fully operational self contained air conditioning system on your boat, and to perform the minor seasonal maintenance required to keep your system in good operational condition.

PRODUCT OVERVIEW

It may be helpful to familiarize yourself with the major components to your system as you unpack them. There are six basic components that make up a complete *mini-kool*® marine air conditioning system:

- *mini-kool*® Self Contained Unit
- Thermostat / Controller
- Seawater Pump
- Pump Relay (if applicable)
- Seawater Kit
- Duct / Grille Kit

All of these components are available from Aqua-Air®. Following is a brief description of each major component:

The *mini-kool*® Self Contained Unit:

The *mini-kool*® unit is commonly used in new installations, however it is very well suited to the replacement or retrofitting of an older, less efficient or obsolete unit, or as an upgrade. This self contained unit is a refrigerant to air heat exchanger that has all the major components mounted on one chassis. It is installed in the area of the boat that is to be heated or cooled. The basic unit is made up of the following major components: compressor, condenser, evaporator, reversing valve, blower, electric box and drain pan.

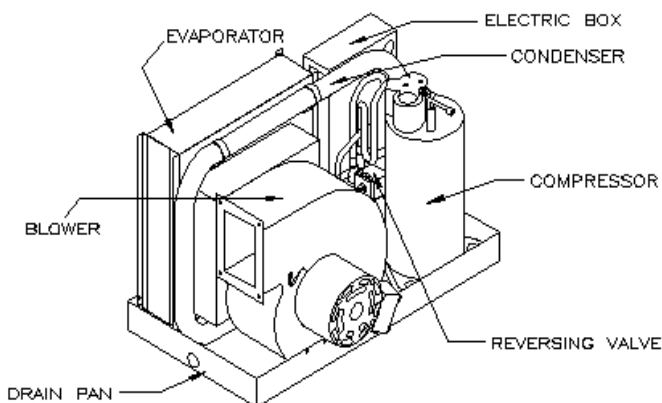

How the *mini-kool*[®] Self Contained Unit Works (Refrigeration 101)

In the self contained unit, refrigerant (either R22 or R407C) is circulated through the system. The refrigerant is pumped from the compressor as a high pressure, high temperature gas through the reversing valve to the seawater condenser. In the condenser, the gas gives off the heat acquired during compression and from the system load, to the seawater passing through the condenser. As this heat is rejected to the water the gas changes state from a gas to a liquid. This liquid then passes through the receiver to the capillary tube(s). The liquid refrigerant passes through the capillary tube(s) where it experiences a decrease in pressure. The lower pressure liquid exits the capillary tube(s) and enters the evaporator. While the cabin air is drawn across the evaporator, it is 'cooled' as the refrigerant absorbs the heat from it and the moisture condenses out of it. The now cool, dry air is supplied back to the cabin by the blower. As the refrigerant absorbs the heat from the air it begins to change state from a liquid back to a gas. This gas then passes through the reversing valve and the suction accumulator back to the compressor, where the cycle begins again. Standard units are reverse cycle allowing them to cool and heat. In the heating mode, the refrigerant flows in the opposite direction through the reversing valve. The condenser and evaporator swap functions and the heat contained in the seawater is absorbed and given off to the air passing through the evaporator. This unit will effectively cool in water temperatures up to 90° F and heat in water temperatures as low as 40° F.

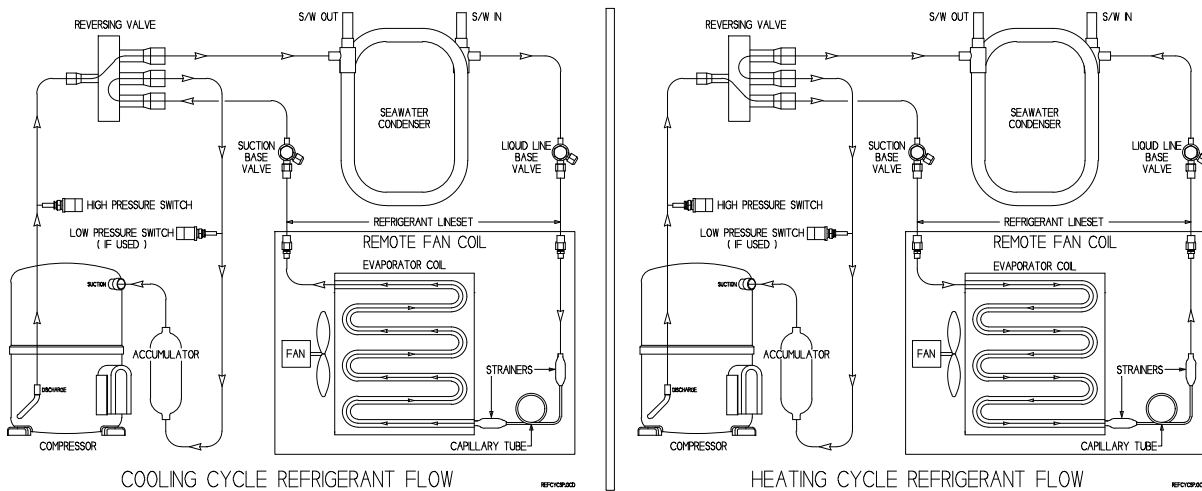

Thermostat / Controllers

The Thermostat / Controller used to operate the *mini-kool*[®] unit can be provided in one of three different configurations:

A. TSV Sapphire Series Digital Thermostat utilizing a Vimar[®] bezel faceplate. Temperature sensing can either be from a remote air sensor or from the sensor that is mounted in the faceplate itself.



B. TWWS-01 Sapphire Series retrofit for the older TWW Tempwise 2000 digital thermostats. Temperature sensing can either be from a remote air sensor or from the sensor that is mounted in the faceplate itself.

C. Three Knob Control AQS3-ZBP Series electro-mechanical thermostat with remote sensing bulb. Used with SMR and SMS models.



Seawater Pump

The seawater pump is used to circulate seawater through the condenser on the self contained unit(s). These are centrifugal pumps and are NOT self priming. This makes it necessary for the pump to be mounted below the ships running water line (under all conditions).

A self contained unit requires approximately 250 GPH for every 12,000BTU/H in capacity. The following table summarizes the seawater flow and pump requirements.



Self Contained Unit Seawater Flow Rates		
Unit Capacity, BTU/H	Seawater Flow in GPH / LPH	Seawater Pump Model
5,000 to 12,000	250 / 946	AQPM-02
12,001 to 24,000	500 / 1,892	AQPM-05
24,001 to 48,000	1,000 / 3,784	AQPM-10
48,001 to 72,000	1,500 / 5,677	AQPM-15
72,001 to 144,000	3,000 / 11,353	AQPM-30

Please keep in mind that distance and height (head) from where the seawater pump is mounted to where the self contained unit(s) is mounted can have a drastic effect on the overall unit capacity that a particular seawater pump can handle. Please consult the engineering department at Aqua-Air for proper pump sizing and water hose sizes.

Pump Relays

A pump relay is necessary when two or more self contained units are supplied water from a single seawater pump. Aqua-Air® offers three different pump relays:

AQP2R Designed for use with two self contained units and one seawater pump. Both self contained units must be on the same shore line. No external power source is needed. ***This relay is not ignition protected and therefore must not be used on a gasoline powered boat.***

AQP6R This relay is a solid state module which will control a single seawater pump from as many as six separate self contained units. This relay requires an external power source. Because it is solid state it is ignition protected.



Seawater Kit

All of the components necessary to install the seawater circuit (except the seawater pump itself) are included in a seawater kit.

SWKU Seawater Kit for use with the AQPM-02, 05 and 10 pumps and a single *mini-kool*[®] self contained unit.



Included in the kit is a seawater inlet thru hull with a speed scoop, ball valve, seawater strainer, overboard thru-hull, 25' of hose, hose clamps and necessary PVC fittings to complete the average installation. See Aqua-Air[®] brochure "Seawater Kits / SWK Series" #80625 for a complete description of all of the components included in these kits.

Duct / Grille Kit

To transfer the air flow from the self contained unit to the area that you want to heat or cool you will need insulated flex duct, supply and return grilles, grille to flex duct transition boxes and possibly adapter tees. These items can be purchased in kit form from Aqua-Air[®]. We offer the Economy Duct Kit series (DKE) which includes plastic grilles or the Premium Duct Kit series (DKP) which includes wood (teak) framed grilles. A complete description of these duct kits is available in the DK Series Grille & Duct Kit brochure, # 81890. The following diagrams illustrate typical Duct / Grille Kits:

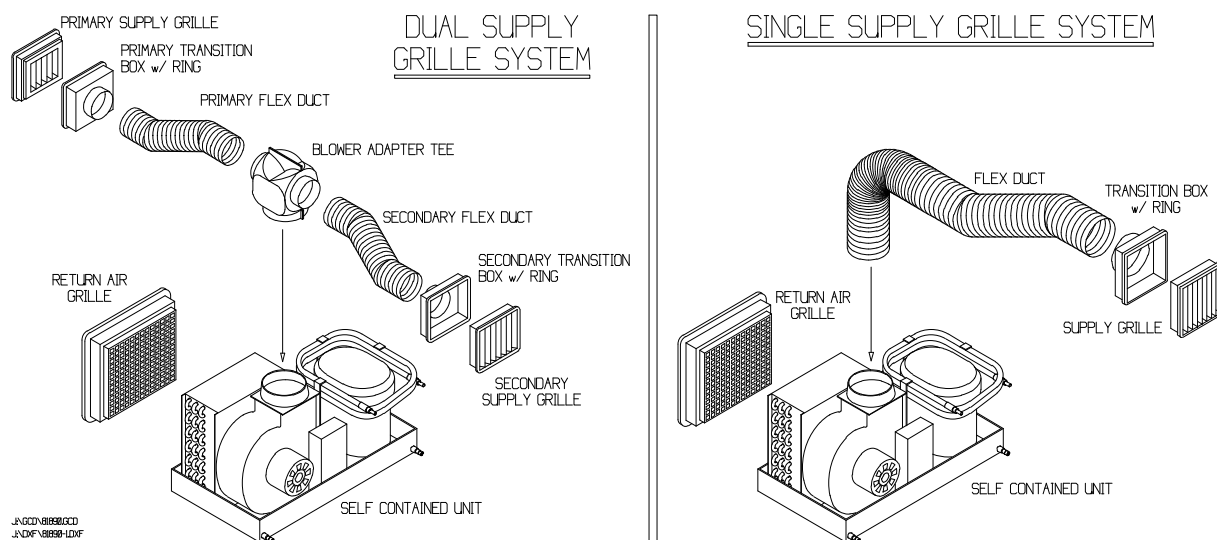

Typical Duct / Grille Kits

★★★ WARNING ★★★

FAILURE TO COMPLY WITH THE INSTALLATION INSTRUCTIONS CONTAINED IN THIS MANUAL COULD PRODUCE HAZARDOUS CONDITIONS RESULTING IN THE INJURY OR DEATH OF THE OCCUPANTS AND THE DESTRUCTION OF THE BOAT. MAKE SURE THAT THE WARNINGS AT THE END OF THIS MANUAL ARE FULLY UNDERSTOOD AND FOLLOWED.

ALL INSTALLATION TECHNIQUES SHOULD COMPLY WITH THE ABYC "STANDARDS FOR RECOMMENDED PRACTICES FOR SMALL CRAFT" SECTION A-6 and E-8.

IF THERE ARE ANY PARTS OF THIS MANUAL THAT ARE NOT CLEAR PLEASE CONTACT Aqua-Air® FOR FURTHER ASSISTANCE.

INSTALLATION OF BASIC COMPONENTS

The *mini-kool*® self contained units are ideally suited for installations in lockers, under bunks or dinette seats. In all applications the self contained unit should be installed as low as possible and the air discharge should be at least three feet above the floor. The best possible configuration is to have the air discharge at or near the ceiling level and the return air near the deck or floor. The reason for mounting in this manner is because cold air is more dense than ambient air and it's natural tendency is to fall to the lowest point in the cabin after leaving the discharge grille. This type of installation creates an ideal air flow for conditioning and dehumidifying the air, and prevent short cycling.

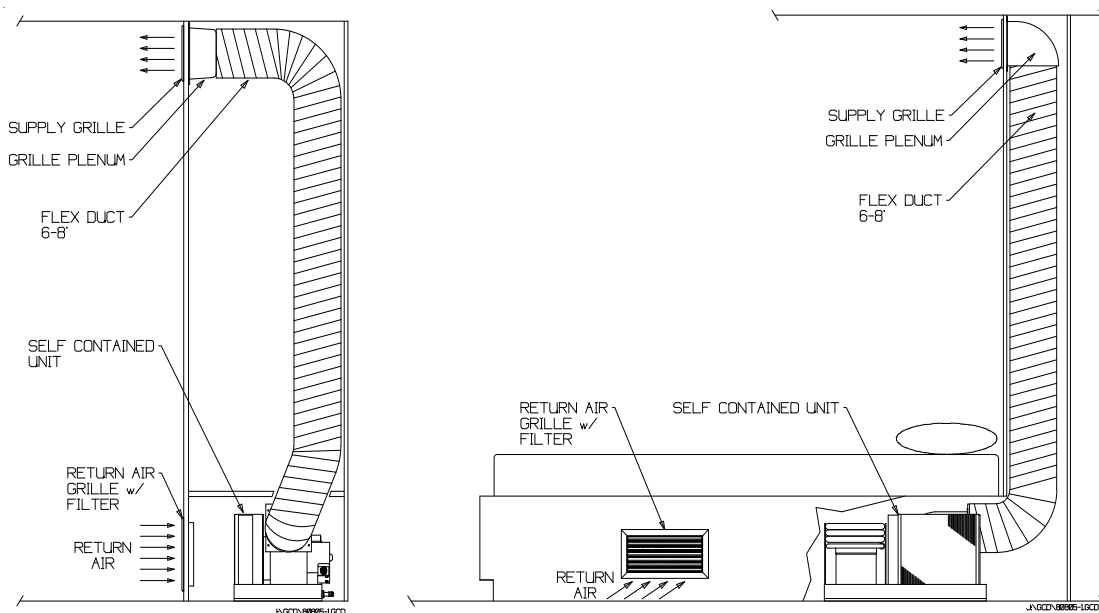

Figure 3 Typical Self Contained Unit Installations

THE SELF CONTAINED UNIT SHOULD NEVER BE MOUNTED IN THE ENGINE ROOM, MACHINERY SPACE OR BILGE AREA WHERE IT COULD DRAW TOXIC FUMES INTO THE UNIT AND THEN DISCHARGE THEM INTO THE LIVING AREA.

The Self Contained Unit should be securely fastened to a firm, level surface using the four mounting clips provided. Please see Figure 4 showing the mounting clip and how it should be used to hold the unit down. There are three possible locations for the drain outlet fittings and one drain fitting is supplied. Remove the aft-facing plug from the drain pan, and follow the guide in figure 4 to install the drain fitting. A 5/8" ID hose from the fitting should then

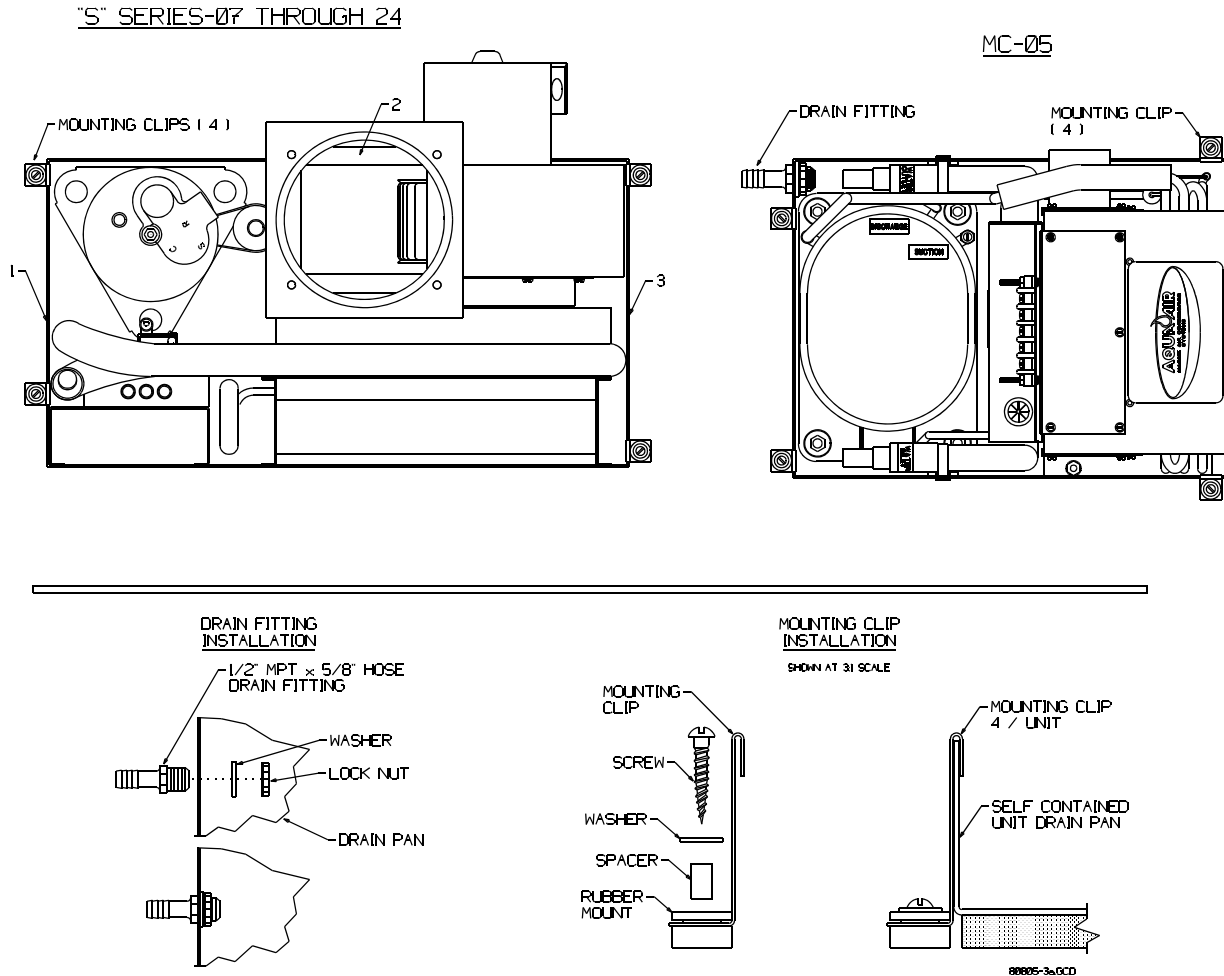

Figure 4 - Drain Fitting Locations and Unit Mounting Details

be run, continuously downward, either overboard or into a shower sump and secured with clamps at both ends. It is not advisable to run the drain lines into the bilge where the condensate can become stagnant and foul smelling when mixed with seawater. On a hot, humid day several gallons of water per hour can be removed from the air by the self contained unit. Any lines, hoses or electric cables run between decks should be sealed away from any exhaust or bilge vapors. *Do not terminate drain lines near engine exhaust outlets nor in the bilge or engine room unless properly sealed to a sump.* After the condensate drain is installed, test it by pouring a quart of water into the pan. It should drain within 30 seconds.

The Blower on all of the self contained units can be rotated allowing for a 130° rotation of the air discharge. To rotate the blower remove the screw at the top of the connecting collar between the blower and the evaporator housing and two screws at the pan. Rotate the blower to the desired position. Drill a 1/8" pilot hole through the existing holes in both the collar and pan. Replace the screws and tighten. Plug the factory holes in the back of the blower if necessary. The correct size plastic blower discharge collar from the chart below, should now be fastened to the blower flange.

Blower Discharge Collar Reference Chart						
Unit	5,000	7,000	10,000	12,000	16,000	24,000
Blower collar diameter	4" 100mm	5" 127mm	5" 127mm	6" 152mm	6" 152mm	7" 178mm
Aqua-Air® P/N	On unit	HA5	HA5	HA6	HA616	AQHA7-24

Insulated Flex Duct should be connected to the plastic blower discharge collar by first pulling back about two inches of the insulation on the end of the flex duct that you are going to attach to the blower. Slip the inner duct over the collar so that at least one of the duct reinforcing wires is up against the flat part of the collar. Install three sheet metal screws around the perimeter of the collar, capturing the reinforcing wire, to hold the duct in place. Wrap a piece of duct tape around the duct that is on the collar. Slip the duct insulation back over the duct that is attached to the collar and duct tape in place.

The Correct Minimum Grille sizes for each self contained unit are shown in the table below. Return air grilles can be larger than listed (this is one case where bigger is better), however, supply grilles should not be any larger than 25% over the recommended sizes. A supply grille that is too large will not properly disperse the air into the room causing hot spots. In either case the grilles must NOT be any smaller than the minimums listed. Small grilles cause decreases in system performance, evaporator coil icing or (in the heating mode) unit shut down due to high head pressures.

Minimum Grille and Flex Duct Sizes			
Unit Capacity BTU/H	Supply Grille in² / cm²	Return Grille in² / cm²	Minimum Duct Diameter, in/mm
5,000	32 / 206	64 / 412	4" / 100mm
7,000	40 / 258	72 / 464	5" / 125mm
10,000	48 / 309	100 / 645	5" / 125mm
12,000	60 / 387	120 / 774	6" / 150mm
16,000	72 / 464	144 / 929	6" / 150mm
24,000	120 / 774	200 / 1290	7" / 175mm

It Is Very Important that there is adequate space for air to return to the self contained unit. While the evaporator of the self contained unit does not have to be directly behind the return air grille there must be an air path of the same area between the return air grille and the self contained unit. Never mount the front of the unit any closer than two inches from a bulkhead as this will restrict the air flow into the evaporator coil.

A Return Air Filter must be in place in the return air grille. This will prevent dirt and lint from being drawn into the evaporator coil, reducing performance. The most common type of filter material is an expanded aluminum type. This is the type used on all return air grilles supplied by Aqua-Air® that have return air filters. These filters should be checked on a monthly basis, during normal usage, and cleaned as necessary.

Seawater Hoses are connected from the seawater pump to the self contained unit and going to the seawater overboard fitting. The hose should be (at a minimum) 5/8" ID, single braid hose. Insert the hoses on the seawater condenser tubes a minimum of 1-1/2" and double clamp in place with a stainless steel hose clamp. Proper hose and clamps are available in the correct lengths and quantities for complete installations in kit form from Aqua-Air®. (See 'Seawater Kits in the PRODUCT OVERVIEW section of this manual)

The Thermostat / Controller is the single control and information center for the *mini-kool*® self contained system. There are two basic types available; electronic and mechanical. The electronic control utilizes a PC board that is factory mounted in the electric box on the *mini-kool*® unit. A 15' display cable is pre-installed and normally, the only installation requirement is the routing of the cable to the location where the digital display head will be mounted and plugged in to the cable. The mechanical control requires routing of a cable and a temperature sensing bulb that are both connected at the self contained unit. Following is a description of the installation of both types. *Note: Templates for mounting controls are located on page 46.*

TSV Digital Controller with Display Panel TWS-01 or TWWS-01 for SSR, SSS Models

Aqua-Air installs the remote air sensor on the self contained unit. The sensing bulb is located in front of the evaporator coil. This allows you to mount the display panel in any location. If, for whatever reason, you would prefer to use the air sensor on the TSV-01 faceplate, disconnect the air sensor at the PC board and change the TSV-01 parameter B1 to "of" (see the Sapphire manual at the rear of this document). The display panel should be mounted over a suitably sized hole (see templates in the back of this manual) with a screw in each corner. The Vimar bezel can then be snapped in place over the TSV-01. A 15' display cable is pre-installed on the self contained unit (longer cables are available from Aqua-Air®). Plug the phone type plug into the jack on the back of the display panel.

3 Knob Mechanical Controls AQS3-Z for SMR, SMS Models

This electro-mechanical thermostatic switch assembly is the central distribution point for the self contained units electric power. The control panel should be mounted over a suitably sized hole (see templates in the back of the manual) using four screws. The plastic cover for the rear of the control must be installed to prevent someone from accidentally touching the exposed electrical connections. The plug end of the wire harness should now be connected to the plug on the self contained unit. Verify that the two plugs are solidly connected. A loose plug connection can cause the unit to malfunction.

The copper temperature sensing bulb must be mounted in the return air flow to the self contained unit. There are two plastic clips on the face of the self contained unit evaporator that are specifically for mounting this sensor. The sensing bulb must never be mounted with the bulb in direct contact with the self contained unit. The bulb should not be mounted on a surface that would be warmer than the surrounding air (i.e. an engine room bulkhead).

Seawater Pumps supplied by Aqua-Air® are all centrifugal, non-self priming pumps. They must be installed in the described manner to insure proper trouble free operation. The pump must be mounted securely at a point in the hull that is *beneath* the waterline of the boat under **ALL** conditions (at rest, under way or in a heavy sea). The position of the pump should be as close as possible to the centerline of the boat, no further forward than the

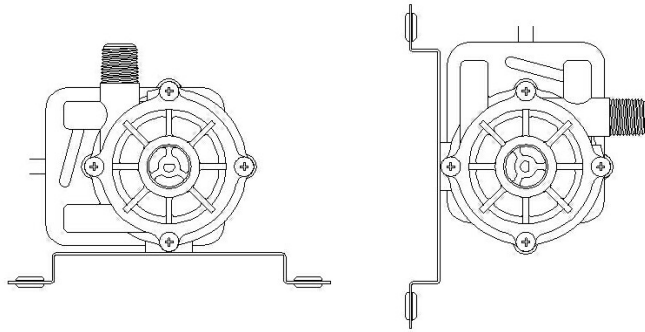

Figure 5

front of the engine compartment and no further aft than the propellor stuffing boxes or aft of the engine compartment bulkhead. The pump should always be mounted in a horizontal position and never on it's head or end. The two positions shown in Figure 5 are the only two acceptable ways to mount the pump. Mounting it in any other way will prevent the pump from self-purging any air that it might ingest.

To make the system self purging there must be a steady uphill run from the seawater inlet to the seawater strainer through the pump up to the self contained unit condenser and then downhill to the overboard (see figure 6). This will allow any air that enters the seawater inlet to bleed off naturally through the seawater system.

Connect the pump wire to the self contained unit according to the applicable wiring diagram in the back of this manual. The ground wire must be connected to the green ground lug.

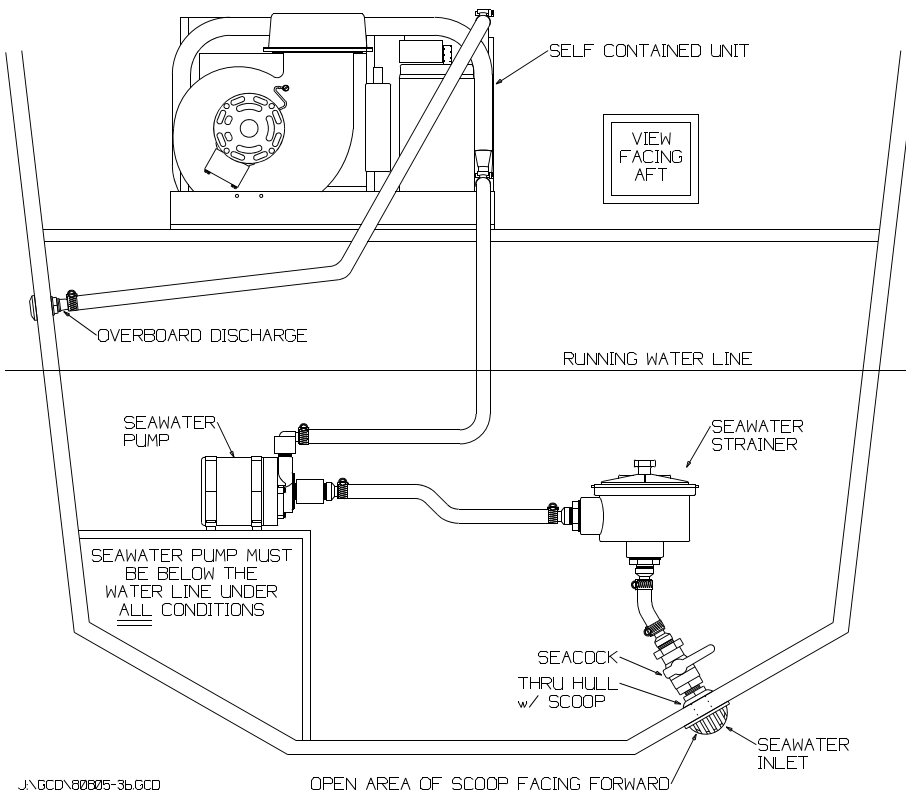

Figure 6 - Typical Seawater Plumbing Circuit

On a system with more than one self contained unit connected to a single seawater pump, the pump will be wired to the pump relay and connected according to the applicable wiring diagram.

The seawater pumps **CANNOT** be run without a supply of water. If they are run dry, internal damage will be caused, voiding the pumps warranty.

Electrical Connections on all *mini-kool*[®] units, are made on the terminal strip located inside the electric box on the PC board. **Turn off a/c power supply circuit breaker before opening the electric box.** To access the terminal strip, remove the screw from the top of the electric box and pull the box cover up and clear of the electric box. The terminal strip is labeled for proper connection of the electric supply, ground wires and pump circuits. Make connections according to the appropriate wiring diagram included in this book.

The correct size circuit breaker should be used to protect the system, and the correct size wire should be used to supply power to the *mini-kool*[®] unit and the seawater pump (see table 3). If two or more self contained units use the same seawater pump, the pump wires will be connected to a pump relay. Power to the pump relay will require a separate breaker. All connections should be made with ring or fork terminals. Field wiring must comply with ABYC Electrical Codes. (AMERICAN BOAT AND YACHT COUNCIL - 410-956-1050)

Recommended Wire and Circuit Breaker Sizes			
Unit Capacity BTU/H	Voltage	Wire Size AWG	Circuit Breaker Rating, Amps
5,000	115	14	10
7,000	115	14	15
10,000	115	12	20
12,000	115	12	20
16,000	115	10	30
7,000	230	14	10
10,000	230	12	15
12,000	230	12	15
16,000	230	12	20
24,000	230	12	20

Table 3

All self contained units must be properly grounded and connected to the ships bonding system. All pumps, metallic valves and fittings in the seawater circuit that are isolated from the unit by PVC or rubber hoses must be individually bonded to the vessels bonding system. Proper grounding and bonding will help eliminate the possibility of corrosion due to stray current or voltage. **Failure to properly ground and bond the system will void the warranty!**

SYSTEM START UP

Before starting the system for the first time the following check list should be verified:

- ✓ **Verify that the unit is not mounted in the engine room or bilge areas, and is sealed away from exhaust or fume producing components!**
- ✓ Proper spacing is allowed around the unit.
- ✓ The self contained unit is securely fastened in place with provided hold down clips.
- ✓ Condensate drain outlets are properly installed and drain lines are routed down hill to a sealed sump (not the bilge).
- ✓ The blower housing is secured if it has been rotated from the factory location.
- ✓ The supply and return grilles meet the minimum area requirements.
- ✓ There is a clean return air filter installed.
- ✓ The insulated flex duct is installed with a minimum of bends and without any kinks that would restrict the air flow.
- ✓ All electrical covers on the self contained unit, control and pump relay are in place.
- ✓ The thermostat temperature sensing bulb or sensor is in the return air flow but not touching the evaporator coil or housing.
- ✓ All wire harnesses or phone wires connecting the thermostat or display head are properly connected to the unit.
- ✓ The electrical power wire is correctly connected to the self contained unit.
CAUTION: MAKE SURE THAT A PROPERLY SIZED TIME DELAY TRIP CIRCUIT BREAKER IS USED IN THE CIRCUIT BREAKER PANEL.
- ✓ Plug in connections for mechanical controls (if used) are properly connected.
- ✓ The self contained unit, pump, relay (if used) and all metal parts in the seawater system are bonded.
- ✓ The pump and/or pump relay wires are correctly connected to the self contained unit.
- ✓ The seawater system is piped in the recommended manner so as to be self purging of air.
- ✓ The pump is mounted well below the running waterline of the boat.
- ✓ There should be a properly sized seawater strainer between the seawater inlet and the pump.
- ✓ There should be a shut off valve (seacock) located between the seawater inlet and the seawater strainer.
- ✓ The seawater inlet is a scoop type with the opening portion of the scoop facing forward.
- ✓ There should be a separate overboard fitting for each self contained unit. It should be mounted no more than 2" above the waterline .
- ✓ The seawater inlet should be no further than 6" from the centerline of the boat.

When Starting the System, the following steps should be followed:

1. Verify that the controls are in the OFF position or mode.
2. Open the seacock on the seawater inlet
3. Verify that the seawater strainer is clean and unobstructed
4. Turn on the circuit breaker(s) for the A/C unit, and the pump (if separate circuit breaker is used for a pump connected to a pump).

Continue the start-up according to the following applicable procedure:

TSV or TWWS DIGITAL CONTROL UNITS:

5. Press the MODE button on the display face. The LED will now indicate the current cabin temperature. This will start the fan motor and seawater pump and compressor. Look over the side of the boat and verify that seawater is flowing from the overboard outlet. If there is no water flow after 15 seconds, press the MODE button to return the unit to the STANDBY mode and find out why there is no seawater flow. The compressor should be on whenever the COMPRESSOR ON light is on.
6. Press and release the MODE button until the desired operation mode is reached (AUTOMATIC operation, COOLING only, HEATING only or Dehumidification mode).
7. View the current thermostat set point by momentarily pressing either the ▲ (increase temperature) or ▼ (decrease temperature) keys. To change the set point, continue to press the ▲ or ▼ key until the desired set point is reached. *(The compressor will run when the cabin temperature is above the set point in the COOL mode and below the cabin temperature in the HEAT modes).*
8. Fan speed operation initially is in the AUTO mode. This means that the fan speed will be automatically selected based on how close the cabin temperature is to the set point. To change the Fan mode to MANUAL press the FAN button. To change the fan speed setting, press the FAN key and then the ▲ or ▼ key until the desired fan speed is achieved. *For further operating information on the TSV Sapphire Control, please refer to the TSV Sapphire Control Operations section of this manual.*

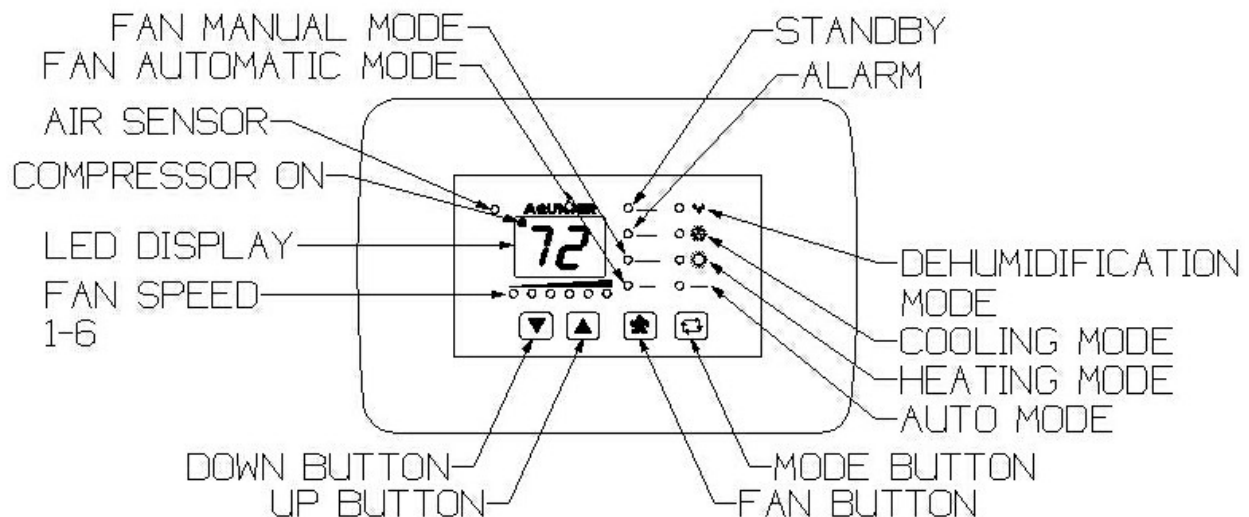

TSV-01 Display Head

MECHANICAL THERMOSTAT

4. Turn the thermostat to the desired setting (either cooling or Heating).
5. Set the Fan speed control to HIGH.
6. Turn the OFF-FAN-RUN switch to the FAN position. This will start the fan motor and seawater pump. Look over the side of the boat and verify that the seawater is coming out of the overboard outlet. If it does not after 15 seconds, turn the OFF-FAN-RUN switch in the off position and find out why there is no seawater flow.
7. Turn the OFF-FAN-RUN switch to the RUN position. The compressor will now start and begin cooling or heating.
8. To set the thermostat to maintain a certain temperature, turn the thermostat toward the center position until a single "click" is heard. The thermostat is now set to maintain the current cabin temperature. To change the cabin temperature by a few degrees, rotate the knob about 1/8" at a time and then wait 15 minutes for the cabin temperature to adjust.
9. Set the fan speed to the desired setting. On the heating cycle, run the fan on low speed for about 15 minutes and then increase to medium speed. This will allow the unit to build up temperature. In the cooling cycle the fan can be run at any speed. In either mode unit capacity decreases as fan speed decreases.

Note: Do not turn the unit off and on rapidly. Allow at least 30 seconds for refrigerant pressure to equalize before restarting the unit.

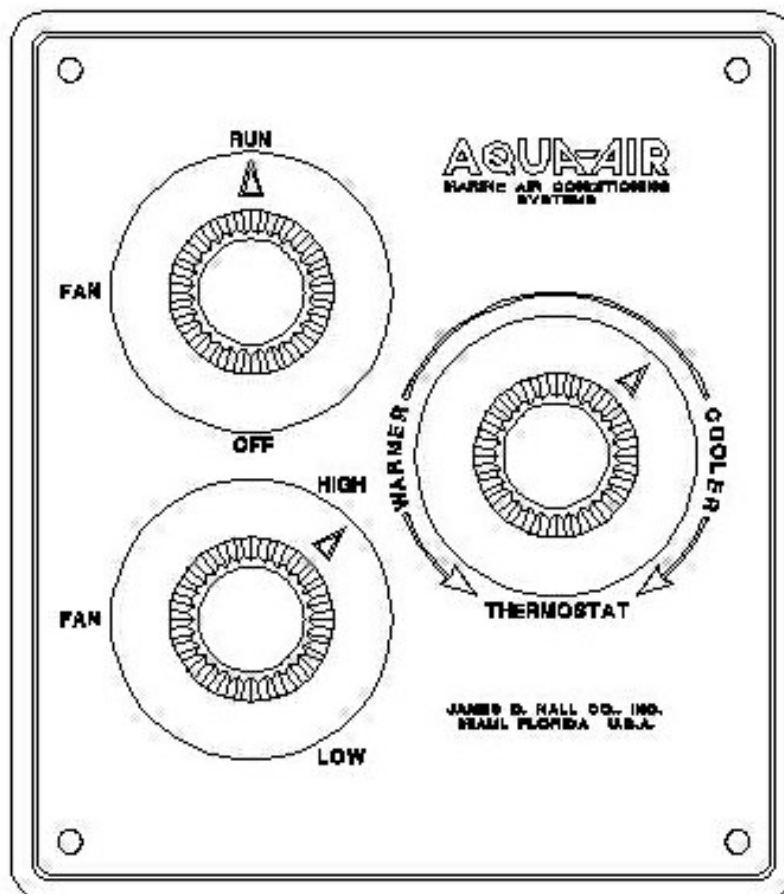

AQS3 Series Mechanical Thermostat Display Panel

MAINTENANCE

Regular Maintenance of your *mini-kool*[®] unit will ensure a high level of efficiency and longevity. Follow these simple routine maintenance procedures:

- ✓ The fan motors should be lubricated on a yearly basis with SAE 20 oil.
- ✓ The drain pans should be checked for proper drainage by pouring a quart of water into the pan. The water should drain within 30 seconds.
- ✓ Clean all return air filters on a regular basis (monthly or sooner as need dictates).
- ✓ Sealed seawater pumps require no maintenance. Larger air cooled pumps will need occasional oiling. See manufacturers labeling on the pump for instructions.
- ✓ Clean the seawater strainer on a regular basis to insure that your pump receives an adequate supply of water. Check the seawater intake for obstructions. Periodically check the overboard discharge for a steady stream of water.

Winterizing the system is a process that ensures that no water is trapped in the unit or seawater system to eliminate the possibility of freezing. This can be accomplished by evacuating the water from the system and/or by flooding the system with a 50/50 non-polluting biodegradable anti-freeze/water solution. Any method that causes the anti-freeze solution to flow downward is the method of choice. Choose one of the following methods:

- ✓ Use pressurized air to force water from the intake through the overboard discharge.
- ✓ Use pressurized air injected at the overboard to force the water through the seawater intake.
- ✓ Use the seawater pump to pump the antifreeze solution through the system exiting through the overboard discharge.
- ✓ Pump the anti-freeze solution into the overboard discharge thru-hull fitting, through the system, exiting at the seawater intake.

Note: All discharged antifreeze solution should be collected and properly disposed of unless it is 100% biodegradable.

TROUBLESHOOTING GUIDELINES

PROBLEM	CHECK THIS	CORRECTION
Unit not starting	Circuit breaker is off	Turn on the A/C circuit breaker
	Control is not turned on	Follow Start-Up instructions
	Incorrect wiring at the terminal strip in the electric box	Check wiring diagram and make necessary changes
	Low input line voltage; TSV display reads LA	Check voltages from power source, wire size and connections
	Loose wiring connections	Check all wiring connections and make corrections as necessary
	Air sensor has failed; display reads AA	Call local service technician or Tech Support at Aqua-Air 800-328-1043
Low air flow	Restrictions in the duct system	Clean return air filter. Remove obstruction in return air stream. Repair any crushed or kinked areas in the ducts.
	Evaporator coil is iced	See below
Evaporator coil is iced	Thermostat set point is too low	Raise the set point on the thermostat
	Low air flow	Clean return air filter. Remove obstruction in return air stream. Repair any crushed or kinked areas in the ducts.
	Supply air too close to return	Change supply air so it is not blowing into return air stream
	Humidity is too high	Close cabin doors and hatches
	Seawater temperature is below 40°	Discontinue use to avoid damage to the unit.
	TSV low fan speed parameter	Reset program P-2
	None of the above or to defrost the coil	Activate the P-7 de-icing cycle or switch from cooling to heating mode to defrost the coil.

PROBLEM	CHECK THIS	CORRECTION
Systems runs continuously	Temperature set point is set too low (cooling) or too high (heating)	Adjust set point on the control.
	Cabin doors and hatches	Close cabin doors and hatches
	Seawater temperature is too high for heating or too low for cooling.	Unit will effectively cool and heat in seawater temperatures between 40° and 90° F
	Location of air sensor	Display head or temperature sensor may need to be relocated
Fan is not running	TSV control programmed for fan to cycle on demand	Reset program A-4 to continuous fan operation
	3 Knob Control improperly set	Set OFF-START-RUN switch to START or RUN
	3 Knob Control fuse blown	Replace fuse on back of control
Fan runs Continuously	TSV control programmed for continuous fan operation	Reset program A-4 to cycle fan on demand
Fan runs Continuously even though it's programmed to cycle	Triac on TSV circuit board has failed	Call local service technician or Tech Support at Aqua-Air 800-328-1043
Fan is not running but compressor is	Fan motor or fan triac on TSV circuit board has failed	Call local service technician or Tech Support at Aqua-Air 800-328-1043
No cooling or heating	Temperature set point is above (cooling) or below (heating) ambient cabin temperature	Adjust set point on the control
	Check for a steady flow from the overboard discharge.	Remove obstruction at the seawater inlet. Clean the seawater strainer. Check for any kinks or crushed hose. Confirm pump is operating.
	Pump is air-locked	Remove hose from the pump outlet to purge air from system
	Low refrigerant gas	Call local service technician or Tech Support at Aqua-Air 800-328-1043
	TSV control programmed for non-reverse cycle heat	Reset program A-5 to "nor"

PROBLEM	CHECK THIS	CORRECTION
No cooling or heating	Seawater temperature is too high for cooling or too low for heating	Unit will effectively cool and heat in seawater temperatures between 40° and 90° F
	Evaporator coil is iced	See above
	High Pressure switch activated; TSV display reads HP	Follow instructions for obstructed water flow. Follow instructions for low air flow.
	Low Pressure switch activated, TSV display reads LP	Possible low refrigerant gas, low seawater temperatures or low return air temperatures. Try restarting after 15 minutes
	Compressor thermal overload is activated due to high pressure.	Compressor must cool down. Turn system off to cool down. (This may take up to 3 hours)
Unit switches to heat when in cooling mode	TSV control de-icing cycle is activating due to coil icing	Verify coil icing and eliminate the cause. Otherwise reset program P-7 to 0 "OFF"
TSV display is not lit	Display cable is unplugged, not making contact or is damaged	With power off, remove and inspect plugs. Inspect entire cable and replace if necessary

★ ★ ★ WARNING ★ ★ ★

Aqua-Air Manufacturing (a division of the James D. Nall Company, Inc.) hereafter referred to as the “Manufacturer” makes the following warnings in regard to the use of its products. Even though these warnings are comprehensive in nature, there are certain dangers that might arise which, at this time, are unforeseeable. A thorough understanding of the dangers outlined below will help as a guide for spotting other potentially dangerous situations. This understanding is very important in assuring your safety.

Electricity - Aqua-Air® products operate on voltages ranging from 24 to 480 volts of alternating current (A.C.) Power. Because of the danger involved with these voltages, all metal components (bases, cabinets, units, pumps, cupronickel , bronze or brass manifolds) must be grounded in some manner to the ship's grounding or bonding system. Some of the relays, switches and thermostats used in the Aqua-Air® systems are not ignition protected. Because of this, the ventilation blower on a boat should be run for five minutes prior to and during the operation of any Aqua-Air® product or system. All electrical connections must be sealed or covered in such a way as to prevent contact by unauthorized personnel. Such contact could lead to permanent injury or death.

Electrolysis - Any electrical leakage of a component can cause electrolysis. This could lead to a deterioration of a thru-hull which could cause leakage of water into the boat which could result in sinking the boat. All Aqua-Air® products must be kept clean and dry. They should be periodically inspected for electrical leakage. If detected, the faulty component should either be repaired or replaced.

Refrigerant - All Aqua-Air® products utilize Refrigerant 22 or 407C. These refrigerants are non-toxic and non-flammable. These refrigerants contains no oxygen and will therefore not support life. When burned these refrigerants deteriorate into potentially lethal gases. If a refrigerant leak is discovered, evacuate all personnel from the area and prohibit the use of any item using an open flame. Due to the high pressures involved in refrigeration systems, eye protection, gloves and long-sleeved clothes should be worn during servicing of a system. Extensive frost burns can occur to the eyes and skin if they come into contact with liquid refrigerant.

Ventilation - To either cool or heat air, Aqua-Air® systems move air through a heat exchanger by means of either a propeller fan or blower system. This process naturally causes a suction on one side of the unit and a pressurized area on the other. These heat exchangers or “cooling units” as they are referred to in our brochures must be installed so that this suction-pressure action does not (1) pressurize an area to the extent of causing structural failure of the area which could cause injury and does not (2) cause a suction in an area where vapors from batteries, fuel or other operating equipment exist. If a cooling unit were installed in this way then these vapors could possibly be discharged into a living space where they could be hazardous. The best way to prevent the introduction of dangerous gases into a living space is to make sure all living spaces are carefully sealed from all other spaces. It is never advisable to completely seal an area without some sort of auxiliary ventilation in the event of lethal gas or fumes escaping from any source.

Condensate - All Aqua-Air® direct expansion cooling units and self contained units produce condensate when operated in the cooling mode. The self contained units and condensing units can produce condensate during operation in the heating mode. This water must be drained overboard. If allowed to drip on wood, dry rot can form causing structural failure. If allowed to drip on electrical components, deterioration of the components can occur. When the cooling unit is in operation, a negative pressure is exerted on the condensate line. Always locate condensate outlets as far as possible from sources of fumes or dangerous gases. These fumes or gases could be drawn into the system due to this negative pressure resulting in a potentially hazardous situation.

★ ★ ★ WARNING ★ ★ ★

Never sleep in an enclosed area in a boat when any equipment, which functions as a direct result of the combustion of a volatile fuel, is in operation (such as engines, generators, oil-fired heaters, etc.). At any time their exhaust system could fail leading to a build-up of dangerous gases within the enclosed area.



DX PRODUCT LIMITED WARRANTY PERIODS

The warranty period on all Aqua-Air DX (Direct Expansion) products is **one year**. Parts and labor are covered per warranty allowance schedules.

The TSV microprocessor controls used in a retrofit on Aqua-Air or any other manufacturer's marine air conditioning equipment will carry a one year warranty. New TSV controls or components of the microprocessor control system purchased to replace out of warranty controls or components will have a one year warranty.

Non-warranty replacement parts and components, other than TSV controls or components, will be warranted for a period of 90 days. This warranty is for parts only, no labor is included. The exception to this category is replacement compressors which carry a one year warranty, including parts and labor from the date they were sold.

Parts and components supplied by Aqua-Air Manufacturing for replacement on any Aqua-Air unit under warranty will be warranted for the remainder of the original warranty period only.

Replacement parts or components used on competitors equipment will have a 90 day warranty. The exception is those parts used in the refrigeration circuit of any competitive brand of air conditioning equipment, which will carry no warranty.

All warranties begin when the customer takes possession of the equipment. The warranty is extended to all owners of the equipment commencing the date the original owner takes possession of it. Verification of original purchase will be required. All warranties are limited to the terms and periods set forth here. Any and all implied warranties are excluded.

Fuses and MOV's are used as safety devices to protect Aqua-Air equipment against over-voltage conditions caused by induced lightning or inductive switching environments. These are not covered under warranty.

Aqua-Air will repair or replace, at its option, components found to be defective due to faulty materials or workmanship, after the component has been examined by Aqua-Air or its authorized servicing dealer. Additionally, Aqua-Air will pay labor costs, as outlined in its Schedule of Limited Allowances, for the removal and replacement of the component. This limited warranty extends to Aqua-Air DX products that have been installed, operated and maintained in accordance with written guidelines available from Aqua-Air.

Aqua-Air reserves the right to change its warranty policies and procedures as well as its warranty allowances without notice.

Aqua-Air equipment is designed and manufactured for long term, trouble free operation when properly operated and maintained. It is strongly recommended that you read your owners manual and fully understand the operations of your Aqua-Air equipment. Any questions you have regarding the operations of your Aqua-Air system or warranty coverage can be directed to your authorized Aqua-Air dealer or to Tech Support at Aqua-Air Manufacturing (800) 328-1043.

AQUAIR

MARINE AIR CONDITIONING SYSTEMS

Sapphire TSV & TWS Series
Digital Thermostat
for
Direct Expansion Split Systems
and Self Contained Units



Table of Contents

1. Introduction	3
TSV Main Components	3
TWS Main Components	4
2. Display Panels for TSV and TWS Thermostats	5
TSV Display Panel Features	6
TWS Display Panel Features	7
3. Power Module Box	9
PC Board Jumpers	9
PC Board Features	10
PC Board Fuses	11
PC Board External Wiring Connections	11
4. Operation of Controls	12
5. Programming Mode	13
Programmable Parameter Chart	14
Fault Codes	15
6. Controls Operation Flow Charts & Diagrams	16
Compressor Operation	17
Auto Fan Speed Operation	18
Fan Speed Process Diagram	19
Cooling Mode Process Diagram	20
Heating Mode Process Diagram	21
Auto Mode Process Diagram	22
Dehumidification Process Diagram	23
Compressor Process Diagram	24
Seawater Pump Process Diagram	24
Reversing Valve Process Diagram	25
Deicing Mode Process Diagram	26
LP-HP-LA Alarm Process Diagram	27
7. Wiring Diagrams	28
8. Component Dimensions	32
TSV	32
TWS	33

1. Introduction

The Aqua-Air Sapphire TSV and TWS Series Direct Expansion (D/X) Thermostats have been designed specifically to operate either split systems or self contained units. These systems will usually have a compressor, reversing valve, seawater pump and fan motor(s) . All of these components can be regulated by these thermostats.

The only difference between the TSV and the TWS models is the display head appearance. The TSV has a Vimar® brand bezel surrounding the display and button portion of the display head. The TWS was designed as a retrofit for the older Aqua-Air TW-2000 digital thermostat. The TWS display head is exactly the same size as the older TW-2000. Both controls operate in exactly the same way.

The TSV Thermostat is comprised of the following main components:

1. Display Panel (TSV-01)
2. Display Cable (TSWDC-15)
3. Power Module Box (TSV-02)
4. Room Air Sensor (TW2-SENSOR-07)
5. Outside Air Temperature Sensor (TW2-SENSOR-XX) (optional)

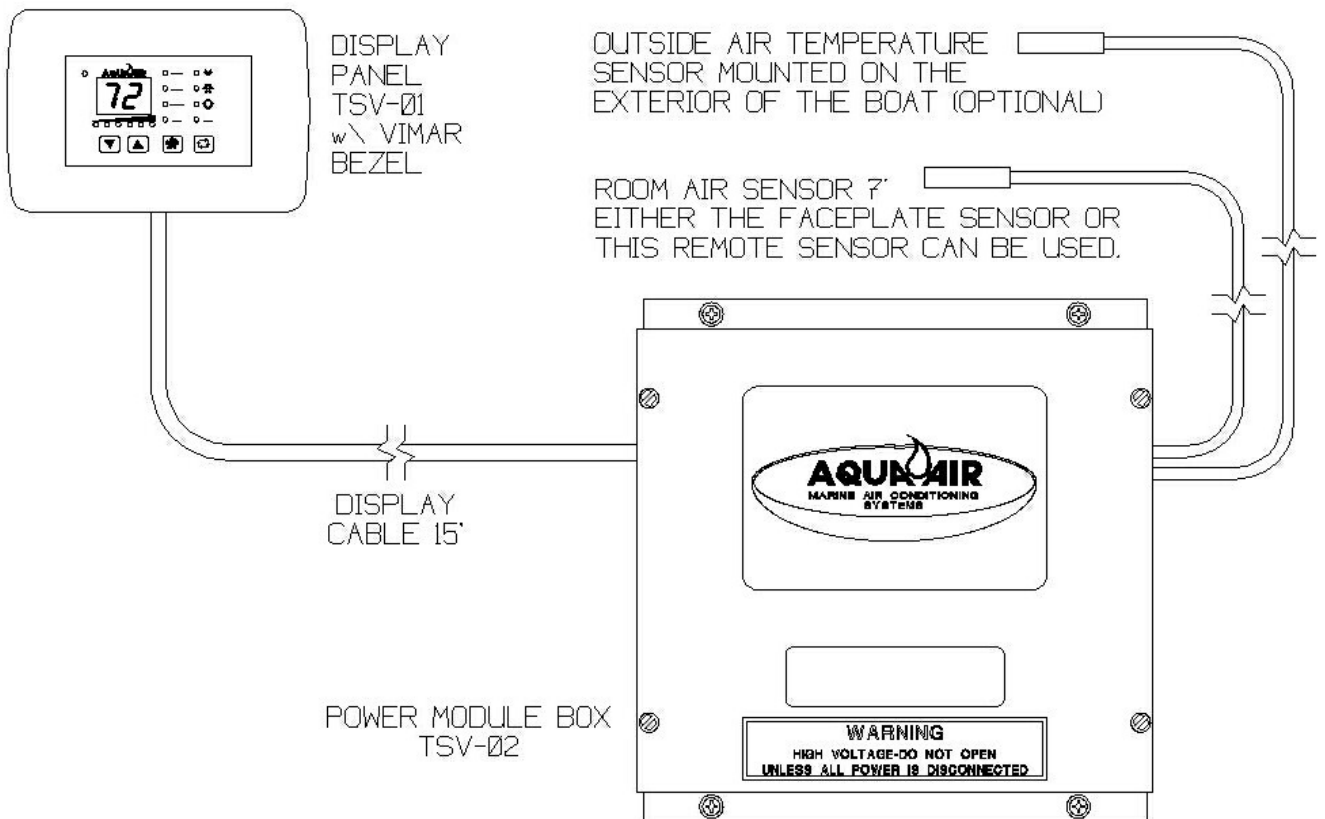

The TWS Thermostat is comprised of the following main components:

1. Display Panel (TWWS-01)
2. Display Cable (TSWDC-15)
3. Power Module Box (TSV-02)
4. Room Air Sensor (TW2-SENSOR-07)
5. Outside Air Temperature Sensor (TW2-SENSOR-XX) (optional)

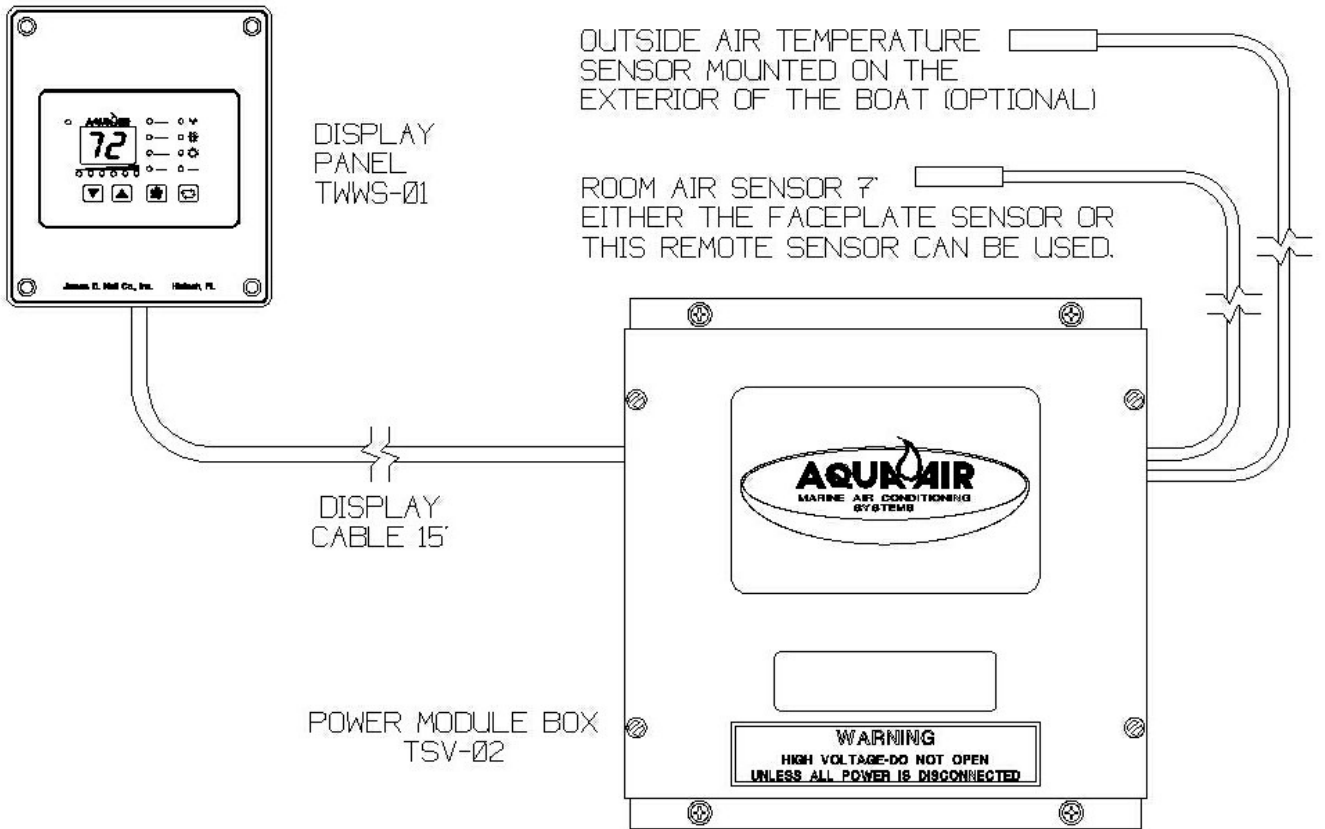

2. Display Panel

The TSV-01 and TWWS-01 Display Panel is the user interface with the TSV Thermostat. It allows the user to make all necessary changes to operating modes, temperature settings and fan speed settings. It also allows the user to make changes to a set of Programming Parameters that controls many of the features of the thermostat.

The Display Panel has been designed to use the Vimar Idea Series metal bezels giving you an almost unlimited number of color options to match any decor. The bezel snaps on and off easily and it hides all of the mounting screws for the display panel

On the following page is a diagram showing all of the features of the Display Panels. The features are applicable for both TSV-01 & TWWS-01 display heads. Each feature has a number associated with it.

Features of the TSV-01 and TWWS-01 Display Panels are:

1. **MODE BUTTON** - The Mode Button is used to select one of the four operating modes and standby (off) mode. Pressing and releasing the Mode Button will advance you to the next mode. Continue to do this until you have reached the desired mode. The available modes are as follows:

STANDBY	Thermostat is OFF, no Cooling or Heating functions are available. The fan can be operated in the Manual mode. Indicated by LED 11.
DEHUMIDIFICATION	Thermostat is in the Dehumidification Mode indicated by LED 14.
COOLING	Thermostat is in the Cooling Mode only, indicated by LED 15.
HEATING	Thermostat is in the Heating Mode only, indicated by LED 16.
AUTO	Thermostat is in the Auto Mode where it will automatically choose between Cooling and Heating as the room temperature dictates. This mode is indicated by LED 17.

2. **FAN BUTTON** - The Fan Button is used to select between AUTO and MANUAL Fan Speed Control as indicated by LED's 12 and 13 respectively. To go from AUTO to MANUAL Mode press the Fan Button once. To change Fan Speeds while in MANUAL Mode press the Fan Button once and then the Up or Down Button to increase or decrease, respectively, the Fan Speed. To switch from MANUAL to AUTO Mode press the Fan Button twice

TSV SAPPHIRE SERIES DIGITAL DISPLAY PANEL

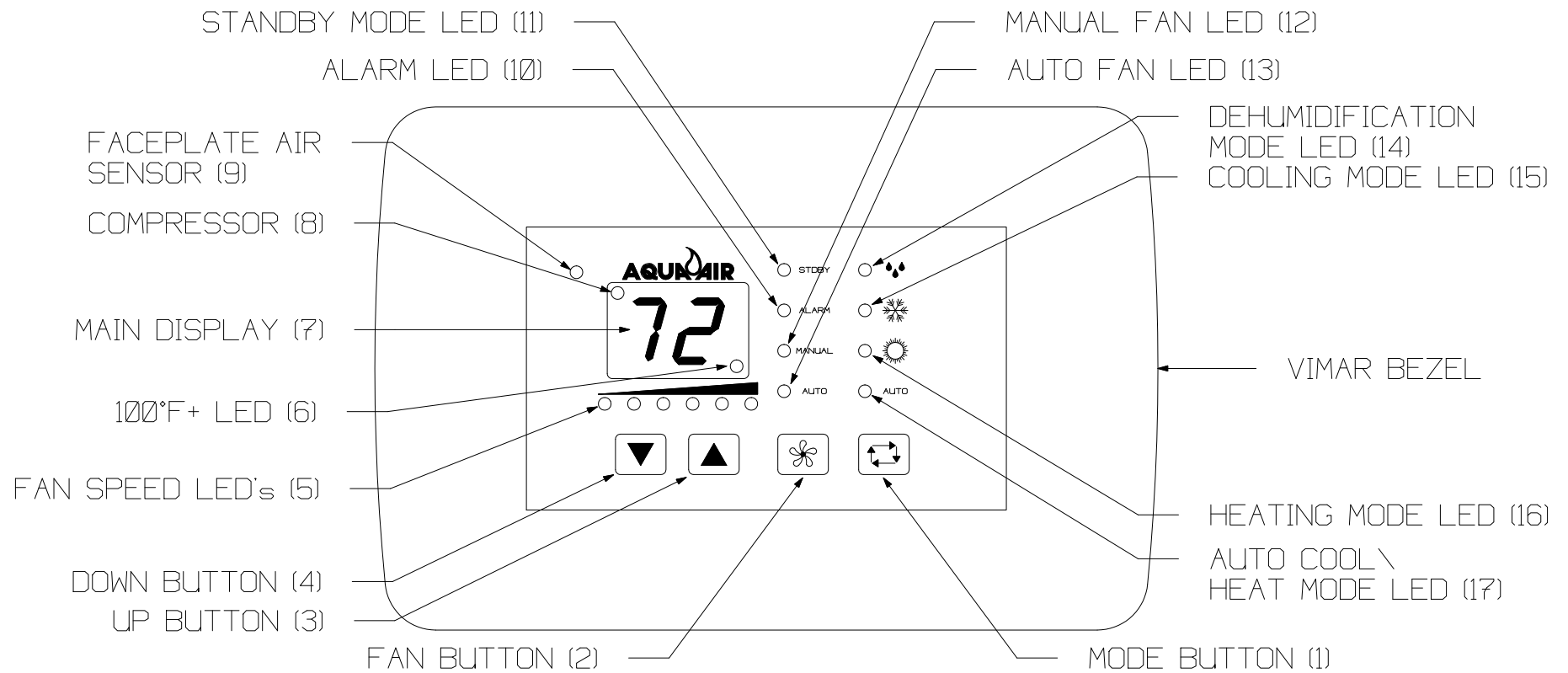

TWS SAPPHIRE SERIES DIGITAL DISPLAY PANEL

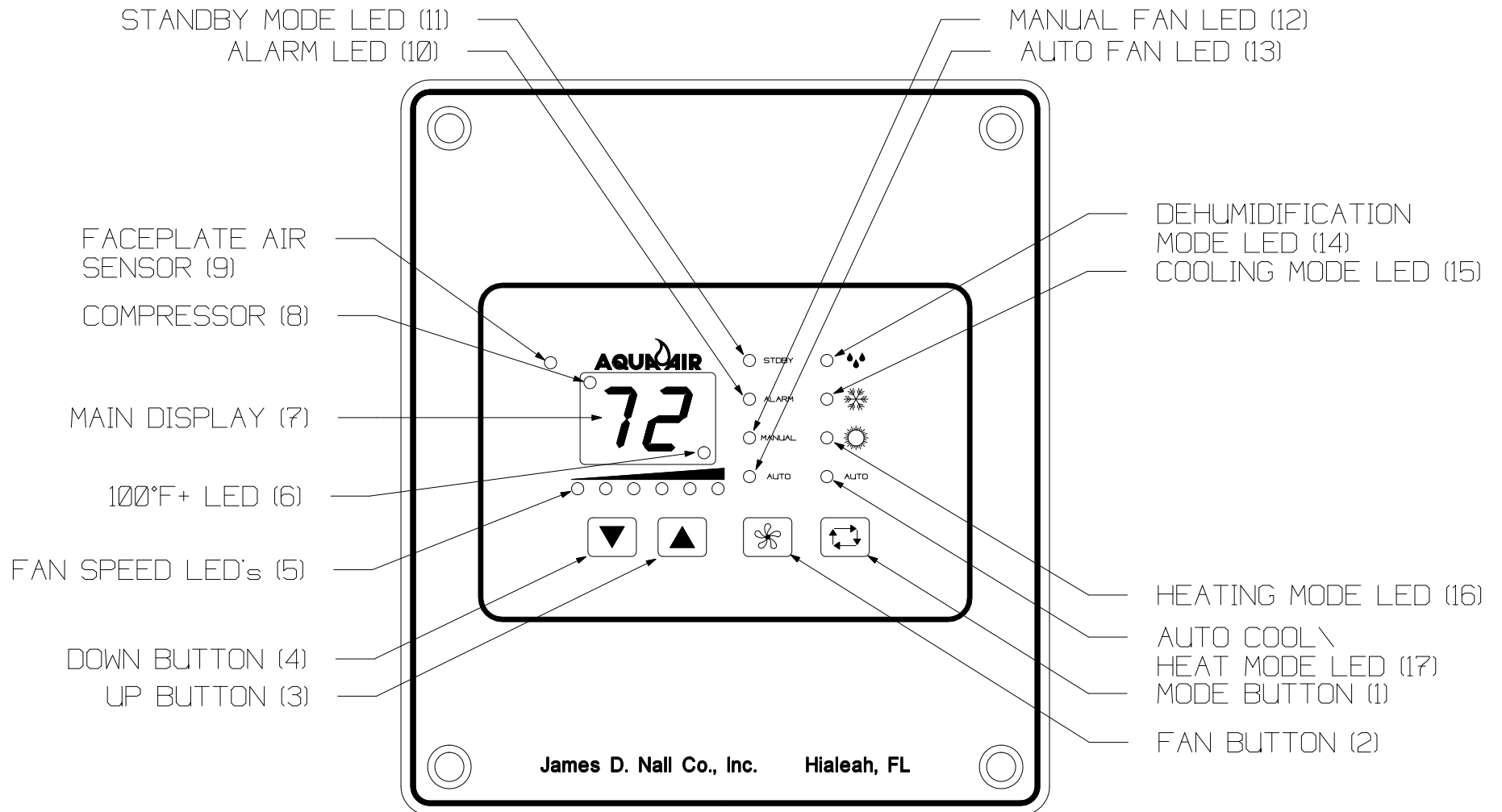

3. UP BUTTON - The Up Button is used to increase values for set points, fan speeds and programmable parameters. During normal operation, momentarily pressing the Up Button will display the Set Point. Continued pressing of the Up Button will increase the Set Point
4. DOWN BUTTON - The Down Button is used to decrease values for set points, fan speeds and programmable parameters. During normal operation, momentarily pressing the Down Button will display the Set Point. Continued pressing of the Down Button will decrease the Set Point.

To view the Outside Air Temperature (OAT) sensed by the optional OAT Sensor:

1. Press and HOLD the Down Button (4)
 2. Press and RELEASE the Up Button (3)
5. FAN SPEED LED's - These six LED's indicate the current Fan Speed 1-6. Low Speed (#1) is the left most LED and High Speed (#6) is indicated by the LED on the far right.
 6. 100°F+ LED - Indicates that the actual temperature displayed is in excess of 100° F. Add the value displayed to 100 to get the actual temperature. If the 100°F LED is lit and the display shows 10 then the actual temperature would be 110°F.
 7. MAIN DISPLAY - This is a 2 digit, 7 segment LED display. Normally the current room temperature is displayed. It can also display the Set Point, Water Temperature, Programmable Parameters and Alarm codes.
 8. COMPRESSOR LED - This LED indicates if the Compressor output has been turned on (in either the Cooling or Heating mode).
 9. FACEPLATE AIR SENSOR - The TSV can use either this Faceplate Air Sensor to sense the room temperature or the Air Sensor that is plugged into the Power Module PC Board. This is selected by Programmable Parameter B1. If the Faceplate Sensor is used it is not necessary to have the Air Sensor plugged into the PC Board.
 10. ALARM LED - Indicates that the control is in a fault condition.
 11. STANDBY MODE LED - Indicates that the control is in the Standby Mode. All Cooling and Heating functions are turned off. If the fan is in the Auto Mode then it will be turned off. If the Fan is in the Manual Mode then the Fan will still operate at the last fan speed selected.
 12. MANUAL FAN LED - Indicates the Fan Speed is in the Manual Speed Selection Mode
 13. AUTO FAN LED - Indicates the Fan Speed is in the Automatic Speed Selection Mode
 14. DEHUMIDIFICATION MODE LED - Indicates that the control is in the Dehumidification Mode
 15. COOLING MODE LED - Indicates the control is in the Cooling Mode

- 16. HEATING MODE LED - Indicates the control is in the Heating Mode
- 17. AUTO COOL/HEAT MODE LED - Indicates the control is in the Automatic Cooling or Heating Mode. In this mode the control will automatically select, based on the room temperature and the set point, whether the control is operating in the Cooling or Heating Mode.

3. Power Module Box

The Power Module Box is comprised of the Main Power PC Board enclosed inside of an aluminum enclosure. The PC Board's main features are shown on the following page.

POWER MODULE PC BOARD JUMPERS				
Jumper	Description	Type	Specification	Notes
JP1	Chillwater / Direct Expansion Selection	Wire	C/W: Jumper Cut D/X: Jumper Not Cut	Do not cut with power applied to board.
JP3	Compressor Relay Test	3 pos. pin	Install jumper in positions 1 & 2 to energize the compressor	
JP4	Pump Relay Test	3 pos. pin	Install jumper in positions 1 & 2 to energize the pump	
JP5	Reversing Valve Relay Test	3 pos. pin	Install jumper in positions 1 & 2 to energize the reversing valve	
JP6	Low Pressure Switch	Wire	LPS connected to J7, positions 2 & 3: Cut No LPS connected: Not Cut	

TSV POWER MODULE P.C. BOARD TWS-PCBOARD

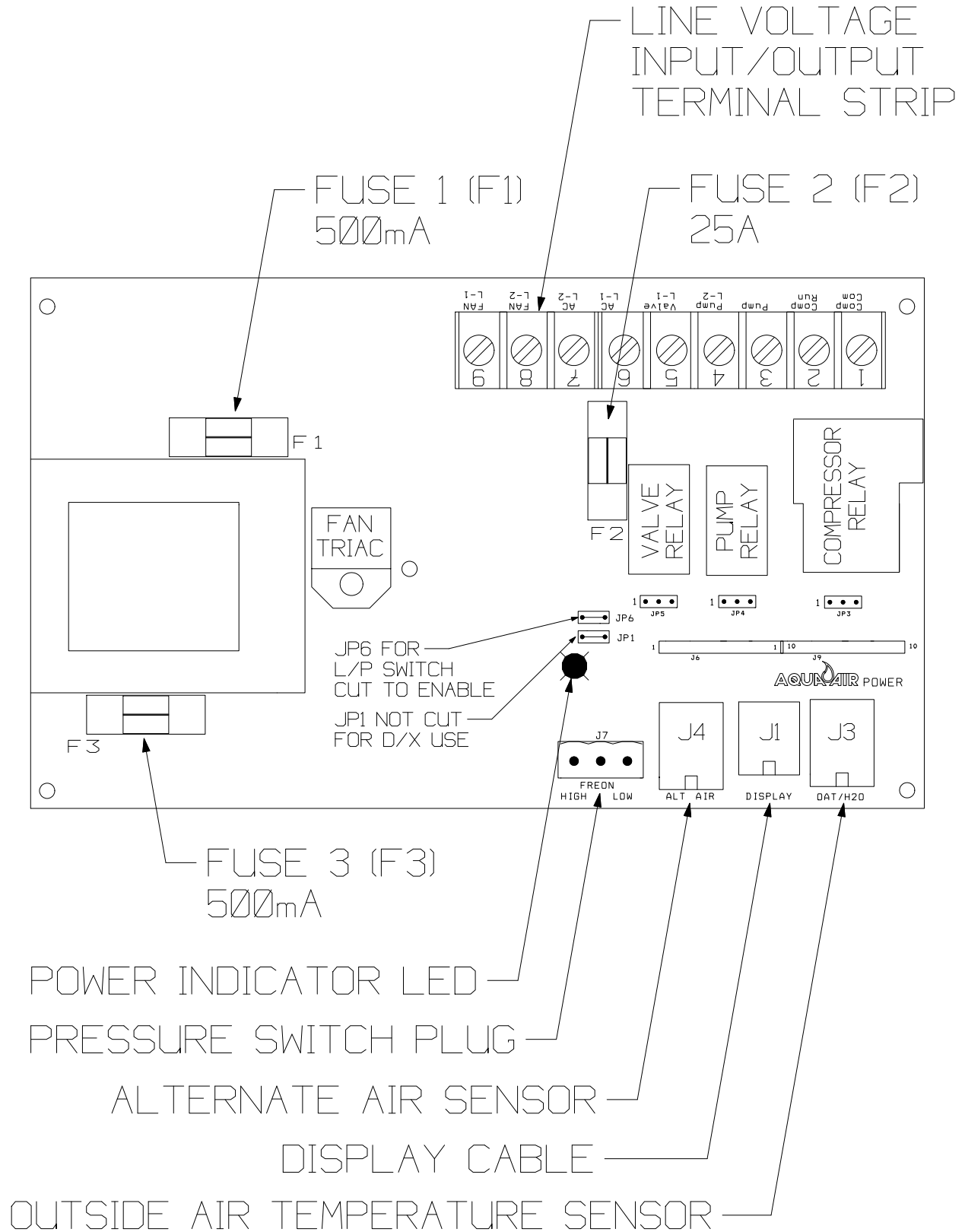

POWER MODULE PC BOARD FUSES			
Fuse	Description	Fuse Amperage Rating	Fuse Size Part Number
F1	Protects against a line voltage short circuit on the primary side of the transformer TX	500 mA (1/2 A)	5mm x 20mm TWS-PCBFUSE1
F2	Protects against a short circuit on the Compressor, Reversing Valve or Seawater Pump circuits.	20 A	5mm x 20mm TWS-PCBFUSE1
F3	Protects against a control circuit short circuit on the secondary side of the transformer TX	500 mA (1/2 A)	5mm x 20mm TWS-PCBFUSE1

**Basic External Wiring Connections to the
TSV and TWS PC Board Located in the Power Module Box**

PC BOARD TERMINAL STRIP

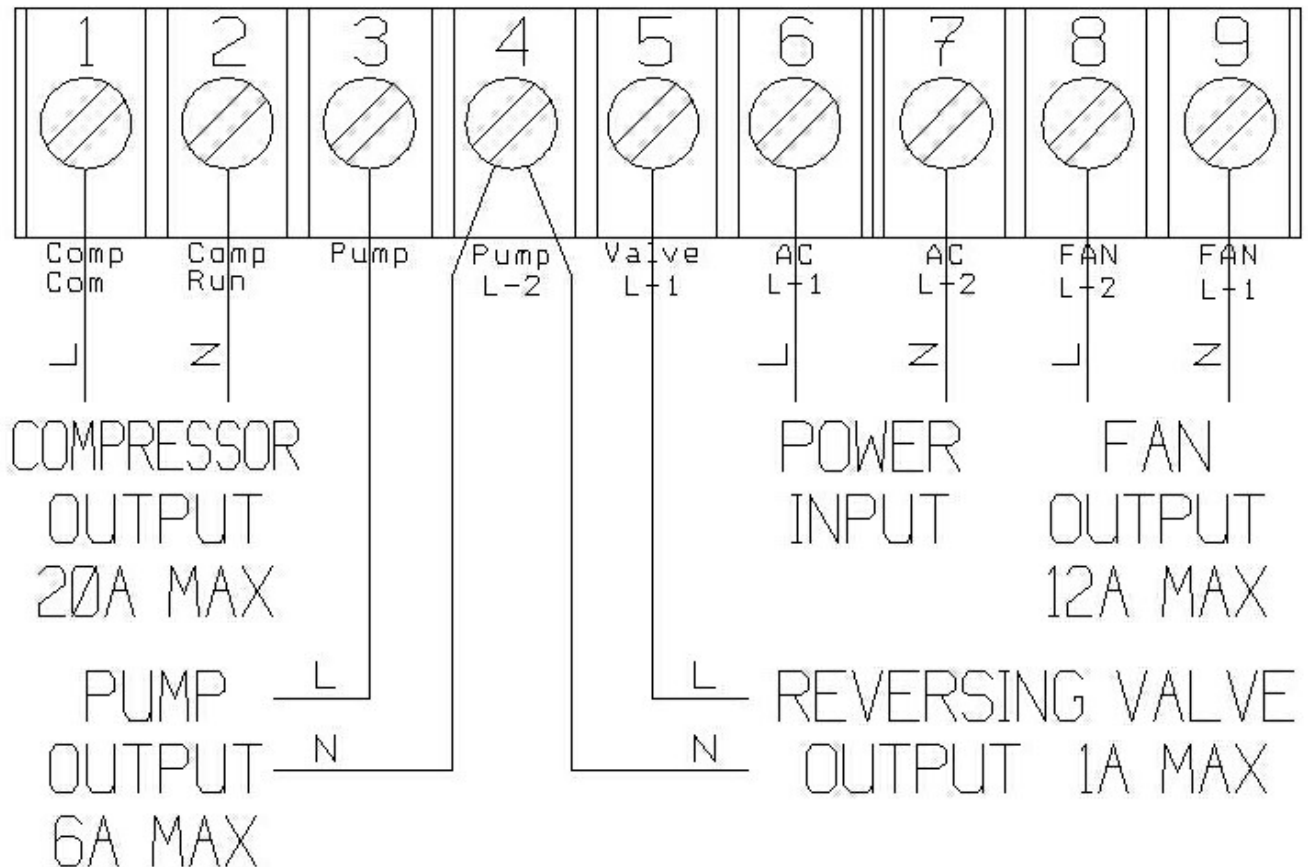

"L" AND "N" REPRESENT "LINE" AND "NEUTRAL" FOR A 115V SYSTEM
"L" AND "N" WOULD BE "L1" AND "L2" FOR A 230V SYSTEM

4. Operation

Below are the steps necessary for the basic operation of the control.

Entering the Cooling Mode

Press and release the Mode Button (1) until the Cooling Mode LED (15) is lit.

Entering the Heating Mode

Press and release the Mode Button (1) until the Heating Mode LED (16) is lit.

Automatic (Auto) Cool / Heat Mode

Press and release the Mode Button (1) until the Auto LED (17) is lit

Entering the Dehumidification Mode

Press and release the Mode Button (1) until the Dehumidification Mode LED (14) is lit.

Turn the Control OFF (Standby Mode)

Press and release the Mode Button (1) until the Standby Mode LED (11) is lit.

View the Set Point Temperature

Press and release either the Up Button (3) or the Down Button (4).

Increasing the Set Point Temperature

Press and release the Up Button (3) until you reach the desired temperature

Decreasing the Set Point Temperature

Press and release the Down Button (4) until you reach the desired temperature

Putting the Fan Mode into Manual

Press and release the Fan Button (2) until the Manual Fan LED (12) is lit

Increasing the Fan Speed in the Manual Fan Mode

Press and release the Fan Button (2) and then press and release the Up Button (3) until you reach the desired speed as indicated by the Fan Speed LED's (5).

Decreasing the Fan Speed in the Manual Fan Mode

Press and release the Fan Button (2) and then press and release the Down Button (4) until you reach the desired speed as indicated by the Fan Speed LED's (5).

Putting the Fan Mode into Auto

Press and release the Fan Button (2) twice

Displaying the Outside Air Temperature

Press and hold the Down Button (4) then press and release the Up Button (3)

Changing the Fan Speeds in the Standby Mode

Press and release the Up Button (3) or the Down Button (4) until the desired speed is reached. To turn the fan off in the Standby Mode press the Down Button (4) until all of the Fan Speed LED's are off.

5. Entering the Programming Mode

There are currently 17 different programmable parameters in the TSV and TWS Thermostats. All of these parameters can be changed from the Display Panel with some simple keystrokes.



The Program Mode can ONLY be entered while the control is in the Standby Mode

To Program the TSV Control:

1. Press the Mode Button until the control is in the Standby Mode which is indicated by the Standby Mode LED (11)
2. Press the Up Button and the Down Button at the SAME time. The first Programmable Parameter code "P1" will appear in the window for 2 seconds and then the P1 setting that is currently stored in the control will appear.
3. To change the parameter setting press and release the Up or Down Buttons.
4. The Fan Button advances you to the next parameter. Advancing to the next parameter SAVES the previous parameter setting. If you do not advance to the next parameter the setting WILL NOT BE SAVED unless you press the Mode Button to exit the Programming Mode (see 5 below).
5. Pressing the Mode Button exits the Programming Mode. Any changes made to any of the parameter settings will be saved.
6. If you do not press any buttons for 30 seconds the control will automatically exit from the Program Mode. The last parameter change will NOT BE SAVED.

Programmable Parameters				
Parameter Number	Description	Default	Range	
P1*	High Fan Speed Limit (% of input voltage)	100 "00."	56 - 100 (100 = 00.)	
P2* **	Low Fan Speed Limit (% of input voltage)	50	30 - 55	
P3	Compressor Staging Time Delay	15 secs	5-135 secs	
P4	Temperature Sensor Calibration	0	-10° to +10° F	
P5	Failsafe Mode	3	Off 1=Continuous, No Display 2=Continuous w/ Display 3=Failure, Reset Required	
P6	Low A/C Voltage Cutoff	115 VAC	85VAC	Off - 75 to 100
		230 VAC	185 VAC	Off - 175 to 200
P7	De-Icing Cycle	0	0=Off 1-3 minutes	
P8	Unused - reserved	N/A	N/A	
P9	Display LED Brightness Control	13	4 = min 13 = max	
A1	Displays °F or °C	°F	°F / °C	
A2	Cycle Pump with Compressor or Continuous Pump Operation	Off	OFF=Cycle w/ Compressor ON=Continuous Running	
A3	Reverse Fan Speed in Heating Mode	rE	No = Normal rE = Reverse	
A4	Continuous Fan Operation or Cycling on Demand	Co	CY = Cycle Co = Continuous	
A5**	Reverse Cycle Heat or Electric Element Heat	nor	nor = Reverse Cycle Heat EL = Electric Heat	
A6	Fan Motor Type, Shaded Pole or Split Capacitor	SP	SP = Shaded Pole SC = Split Capacitor	
A7	Reset Memorized Programming Defaults	nO	nO = Normal Rs = Reset Default	
A8	Unused - reserved	N/A	N/A	
A9	Unused - reserved	N/A	N/A	
CONTINUED ON THE NEXT PAGE				

Programmable Parameters (cont)			
Parameter Number	Description	Default	Range
b1	Air Temperature Sensed from the Display Panel or the Air Sensor connected to the PC Board	on	on = PC Board of = Display Panel
b2	Delay Before Fan Turns Off	30s	30 - 199 seconds

* P1 and P2 values are expressed as a percentage of the input voltage. If the setting for P1 is 90 then the maximum voltage output at high fan speed (speed 6) will be approximately 90% of the input voltage. As you are changing the settings in P1 and P2 the fan will operate and change according to the settings you are entering.

** If Electric Heat is selected (A5 = EL) then P2 must NOT be set lower than 50 and parameter b2 must be set to a minimum of 60 seconds.

FAULT CODES	
Code	Description
AA	Air Sensor Failure or Disconnected. If you get this error code and you intend to use the air sensor on the Display Panel change Parameter b1 to "of".
E1	Display cable damaged. Check to see if the cable has been cut or otherwise damaged.
HP	High Refrigerant Pressure. The seawater flow to the condensing unit has been interrupted
LA	Low Voltage Input to Power Module Box. Check your incoming voltage to the Power Module Box and verify that it is within +/-10% of the rated voltage
LP	Low Refrigerant Pressure. This fault can be due to restricted air flow through the evaporator coil or a refrigerant leak.

6. Control Operation Flow Charts and Diagrams

On the following pages are flow charts and graphic representations of how the control operates the compressor, fan, reversing valve and pump in each of the 4 operating modes. Some of the abbreviations used are as follows:

TERM	Definition
Abs	Absolute Value. The Absolute Value of 5 is 5. The Absolute Value of (-3) is 3. The Absolute Value of an equation that returns a negative number is always a positive number. Therefore $Abs(3-8) = 5$
DELTA	Difference between two values. As used in this manual it is the difference between two temperatures
Hysteresis	The lag between making a change, such as increasing or decreasing temperature, and the response or effect of that change. It typically refers to turn-on and turn-off points. For example, if a thermostat set for 70 degrees turns on when the temperature reaches 68 and turns off at 72, the hysteresis is the range from 68 to 72.
LED	Light Emitting Diode. These are all of the lights on the display panel. The two 7 segment numerical displays are each made up of 7 individual diodes.
OAT	Outside Air Temperature
Tair	Air Temperature as sensed by either the Display Panel or Room Air Sensor
Tset	Set Temperature of the thermostat

COMPRESSOR OPERATION

COOLING MODE

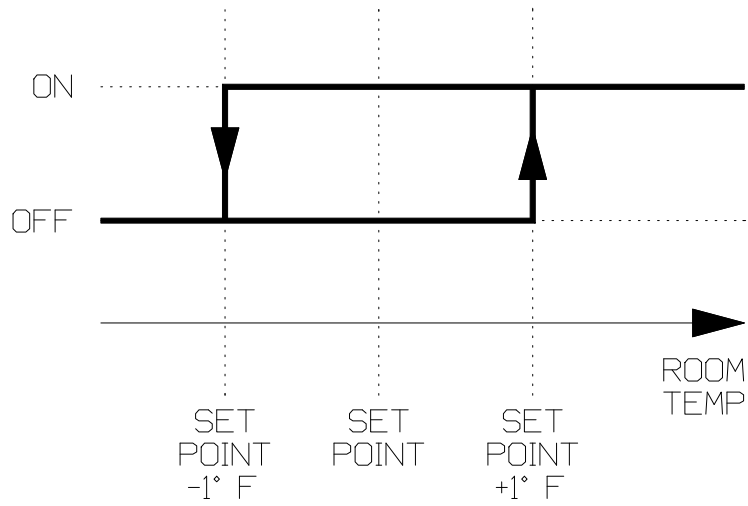

HEATING MODE

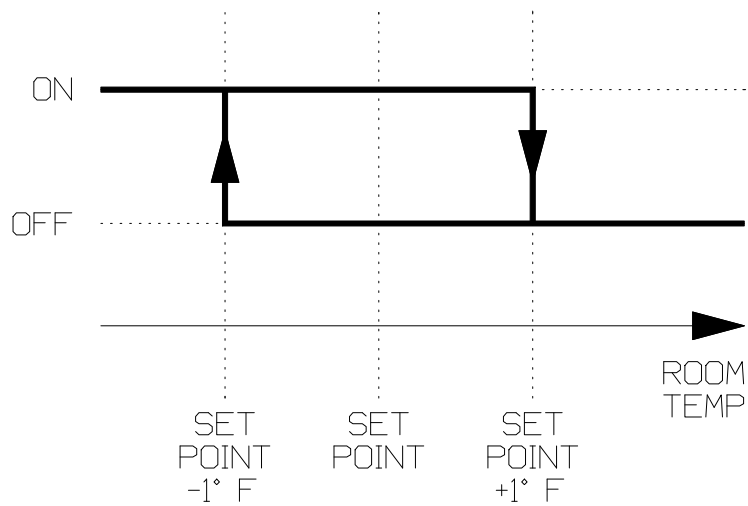

AUTOMATIC FUNCTION MODE CHANGEOVER

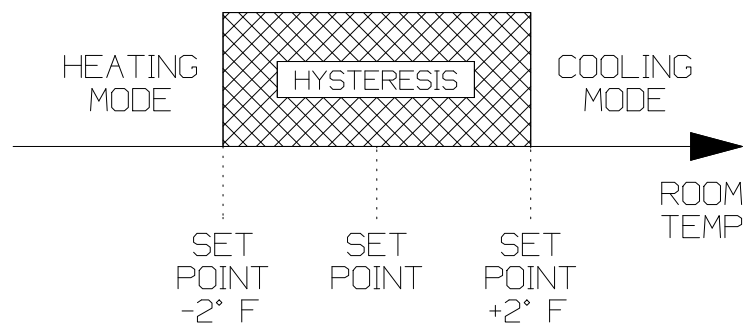

AUTO FAN SPEED OPERATION

COOLING MODE

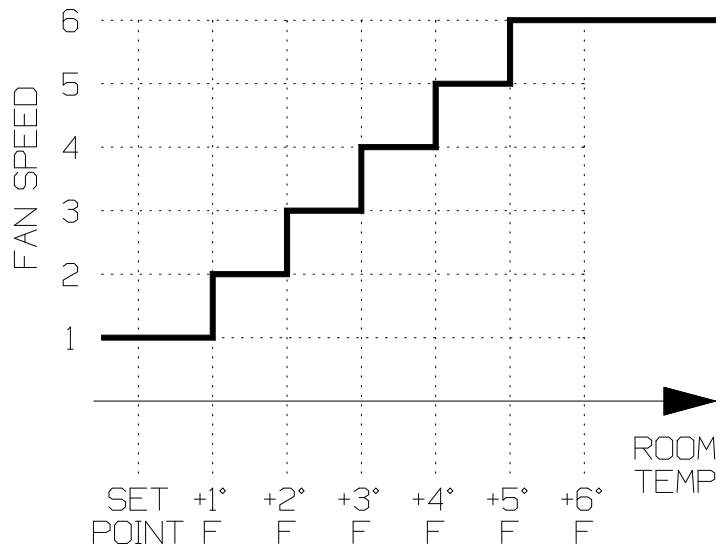

HEATING MODE

PARAMETER A3 = NORMAL (No)

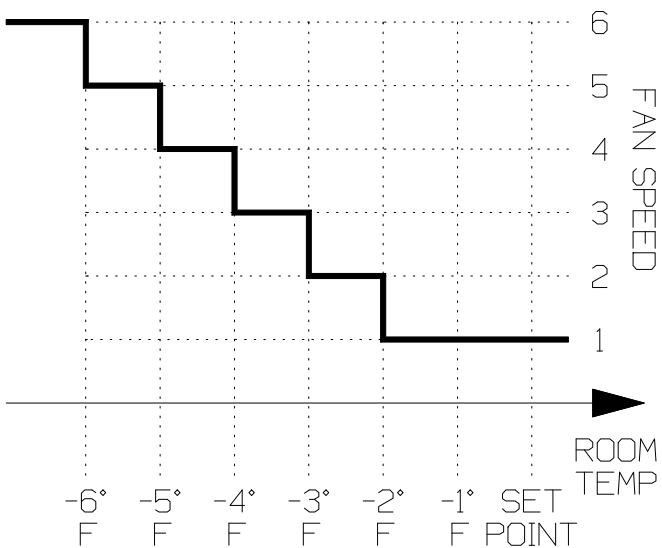

HEATING MODE

PARAMETER A3 = REVERSE (rE)

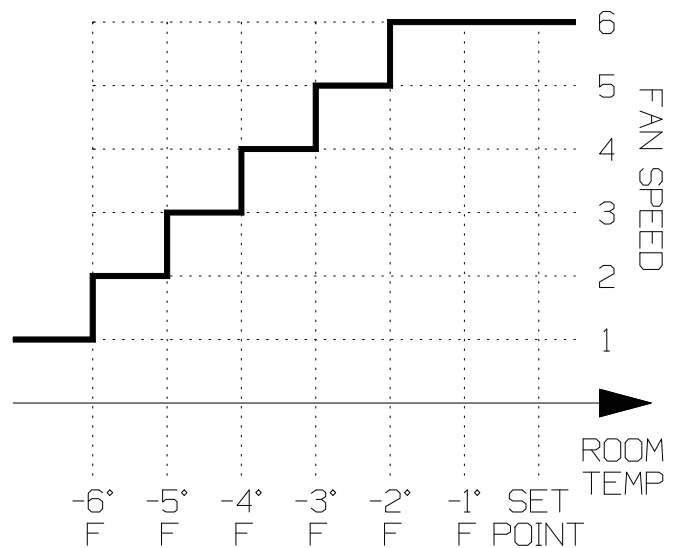

FAN OPERATION & SPEED SELECTION

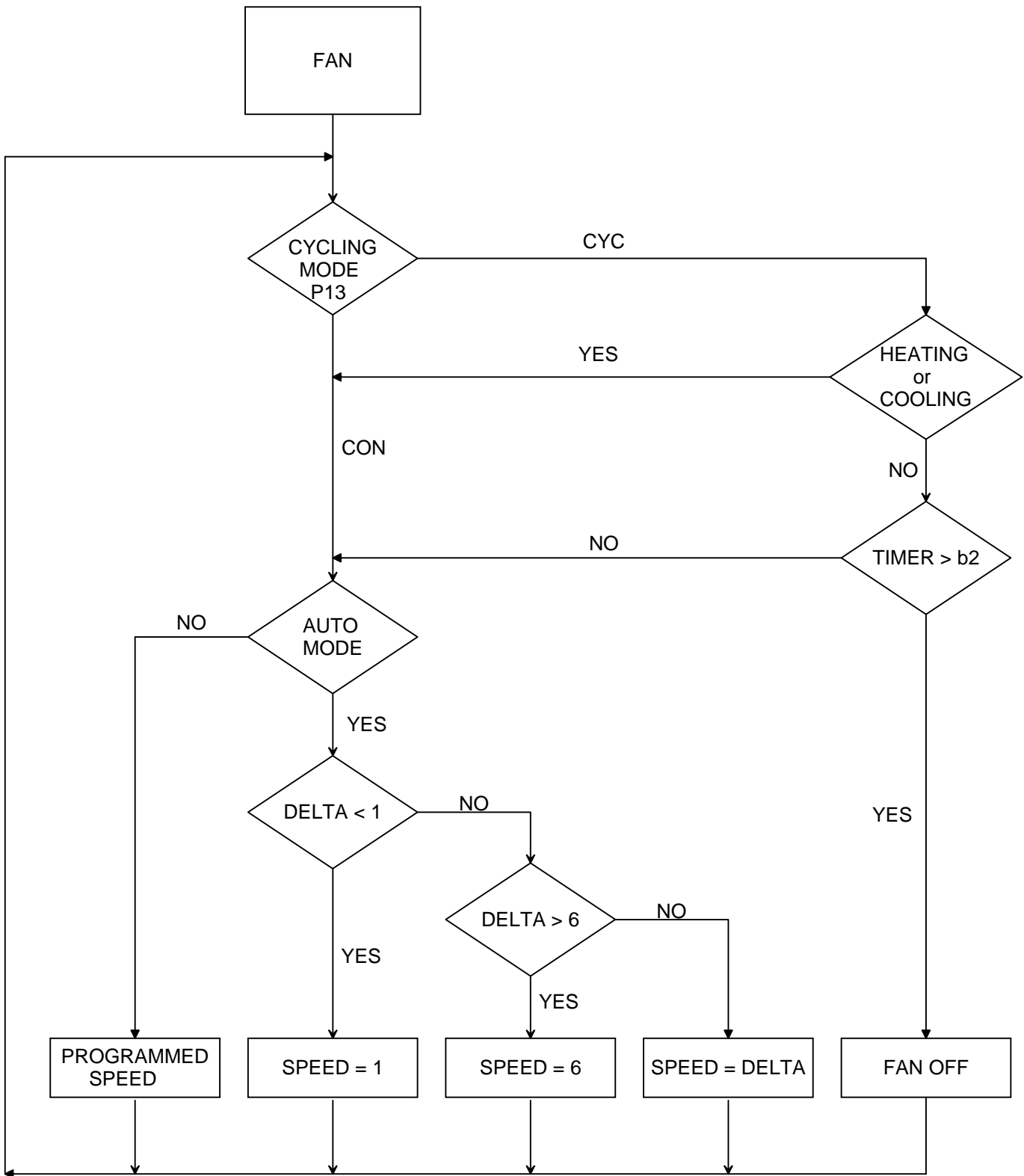

Normal Fan Operation
 $DELTA = Abs(T_{air} - T_{set})$

Reverse Fan Operation
 $DELTA = Abs[Abs(T_{air} - T_{set}) - 6]$

COOLING MODE

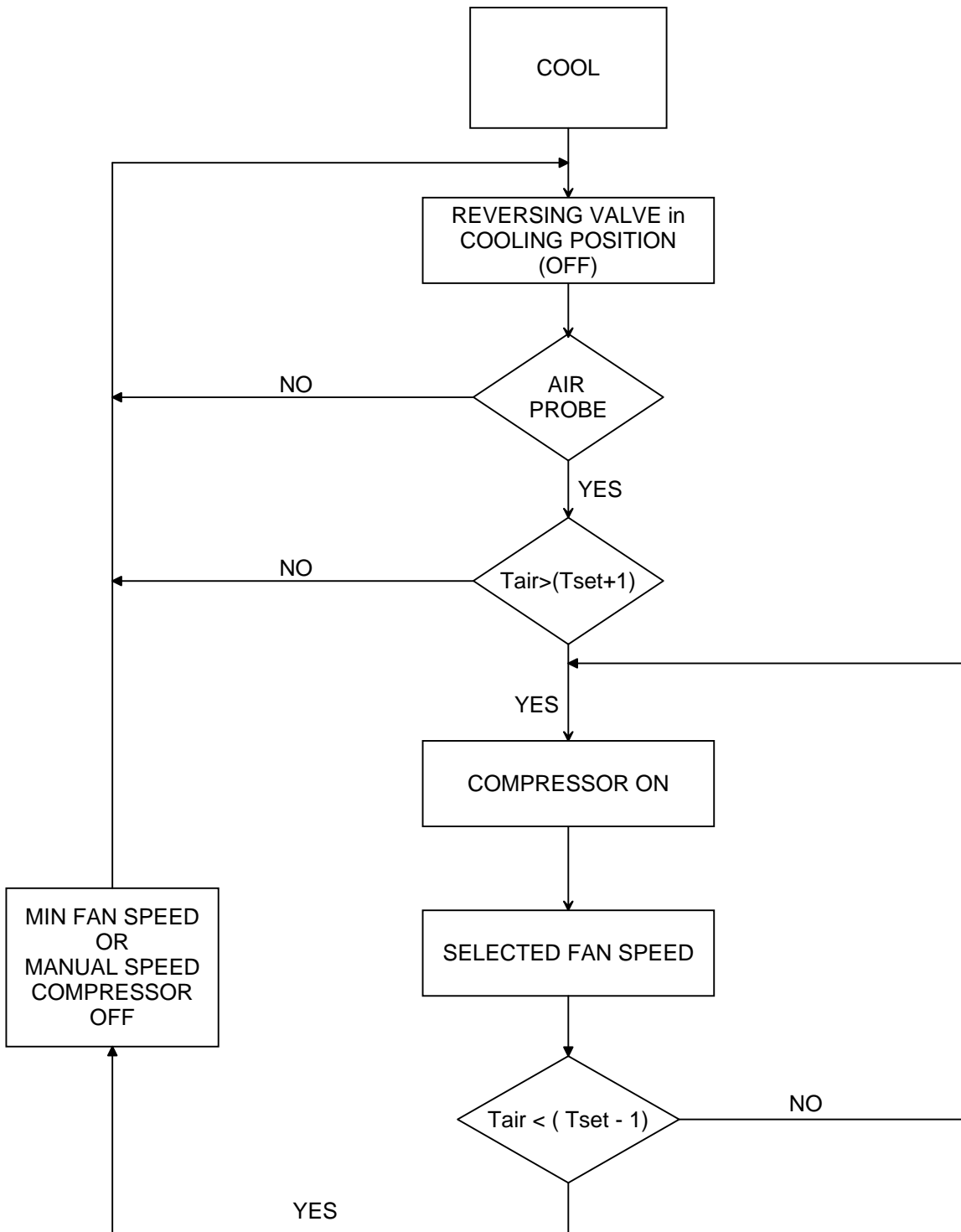

HEATING MODE

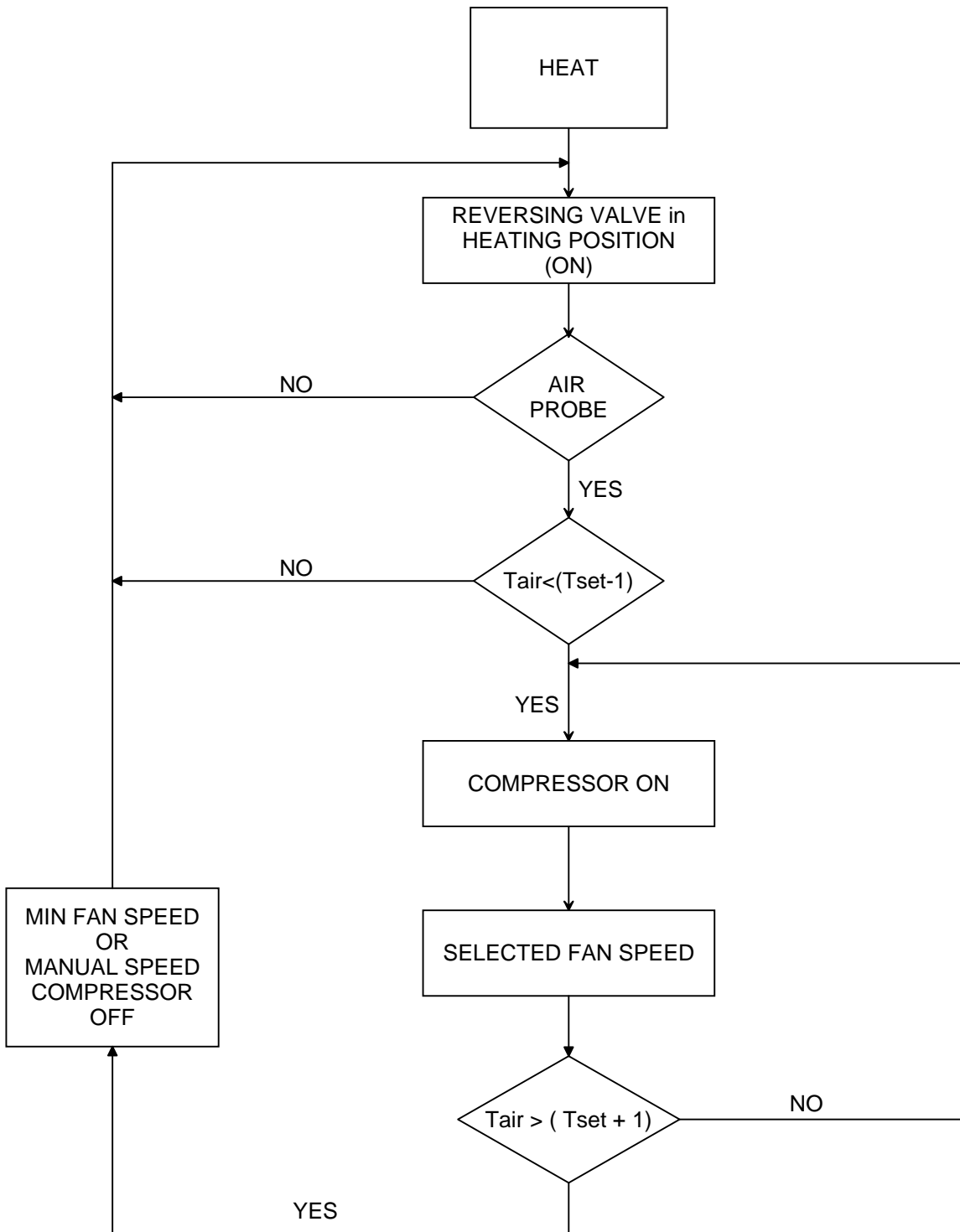

AUTO MODE

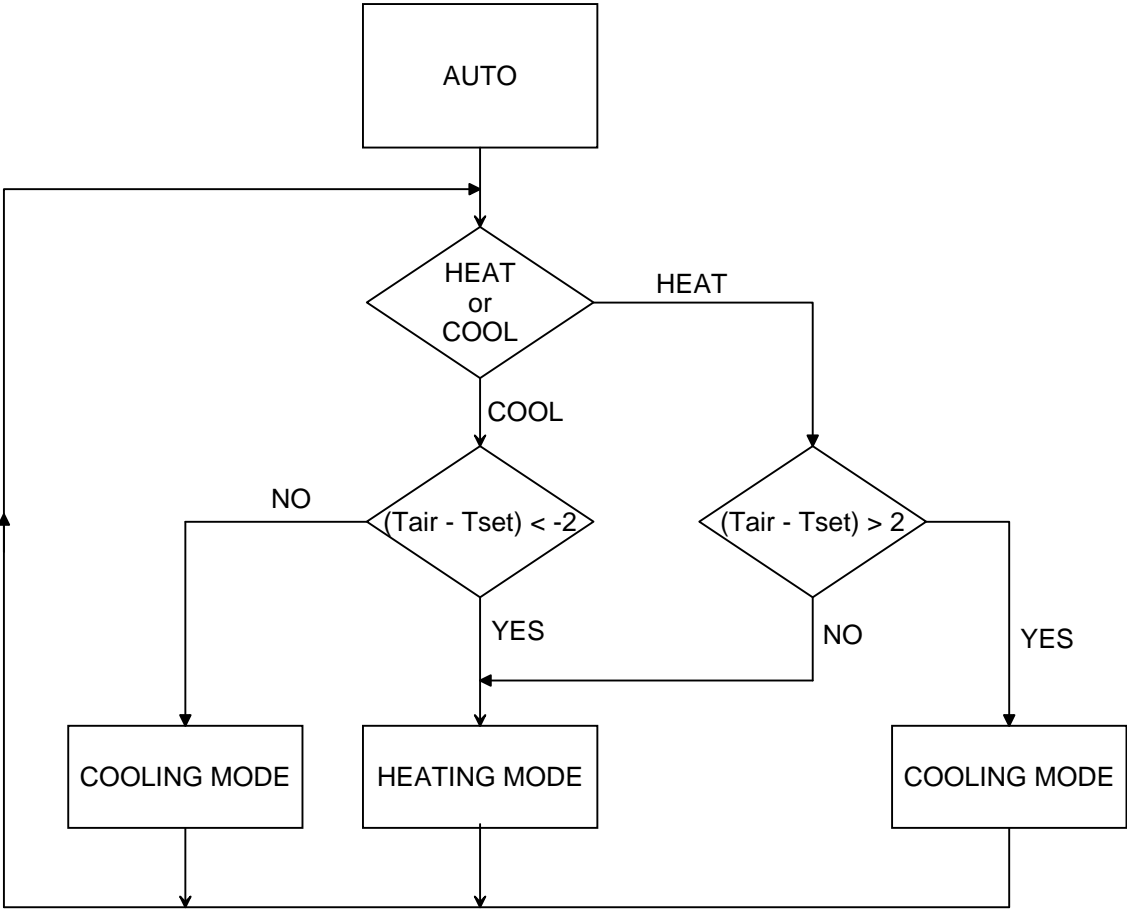

DEHUMIDIFICATION MODE

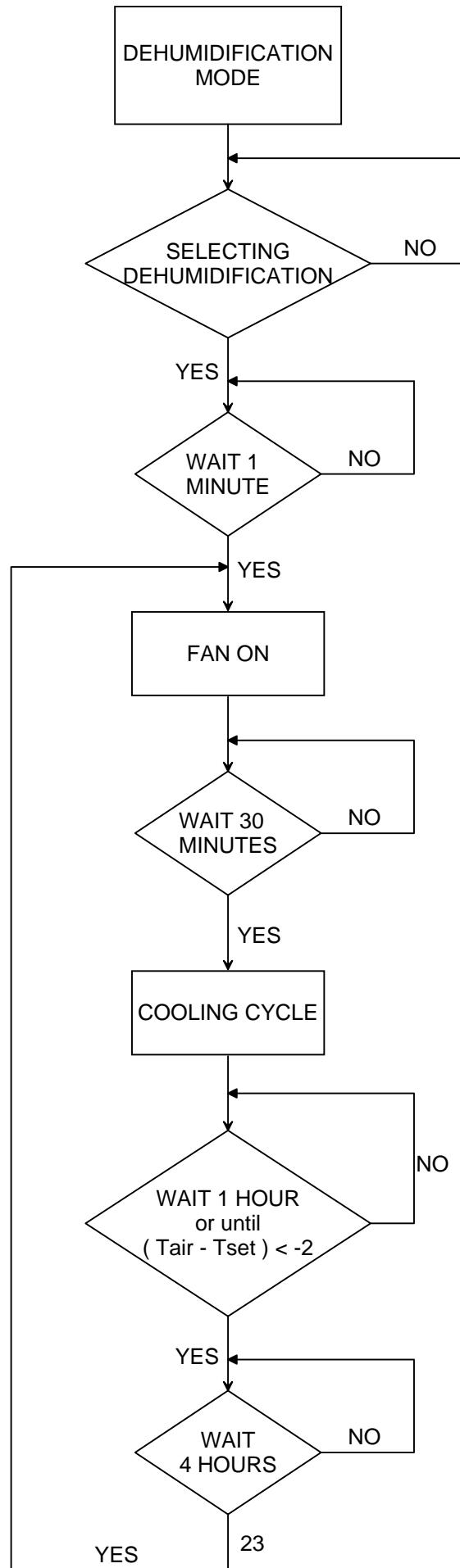

COMPRESSOR

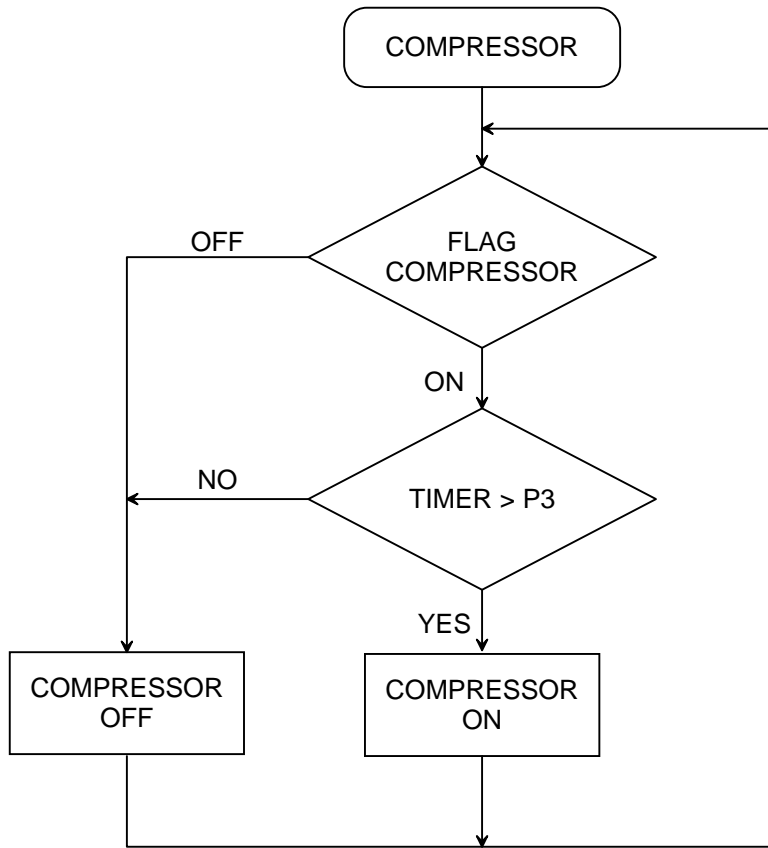

P3 REFERS TO
PROGRAMMABLE
PARAMETER P3

SEAWATER PUMP

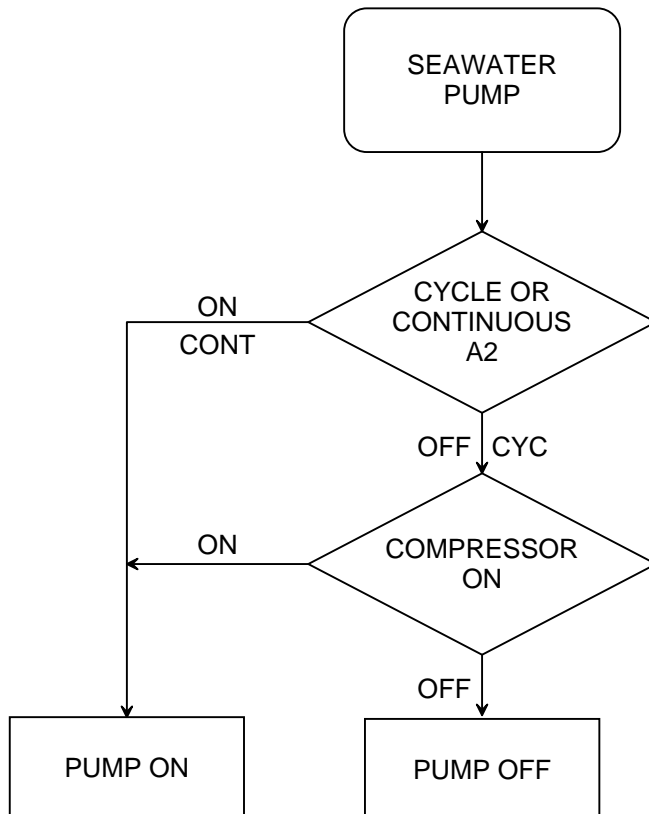

A2 REFERS TO
PROGRAMMABLE
PARAMETER A2

REVERSING VALVE

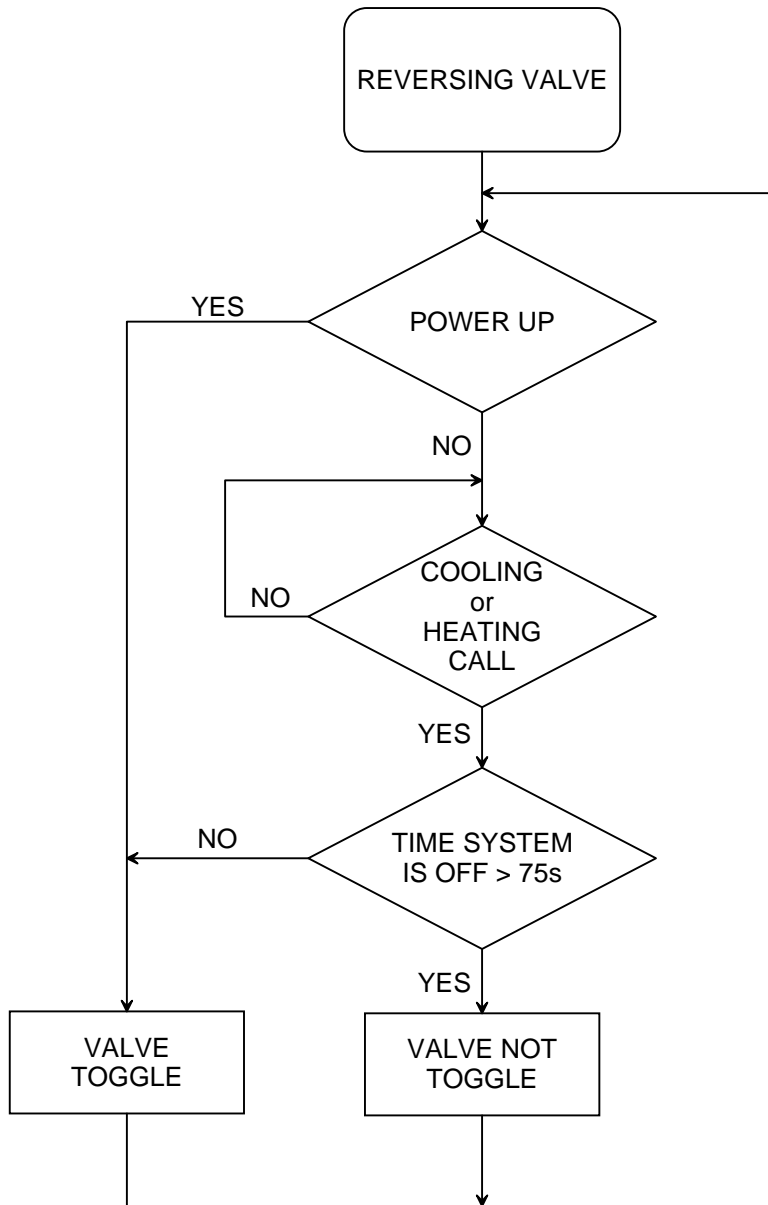

DEICING MODE

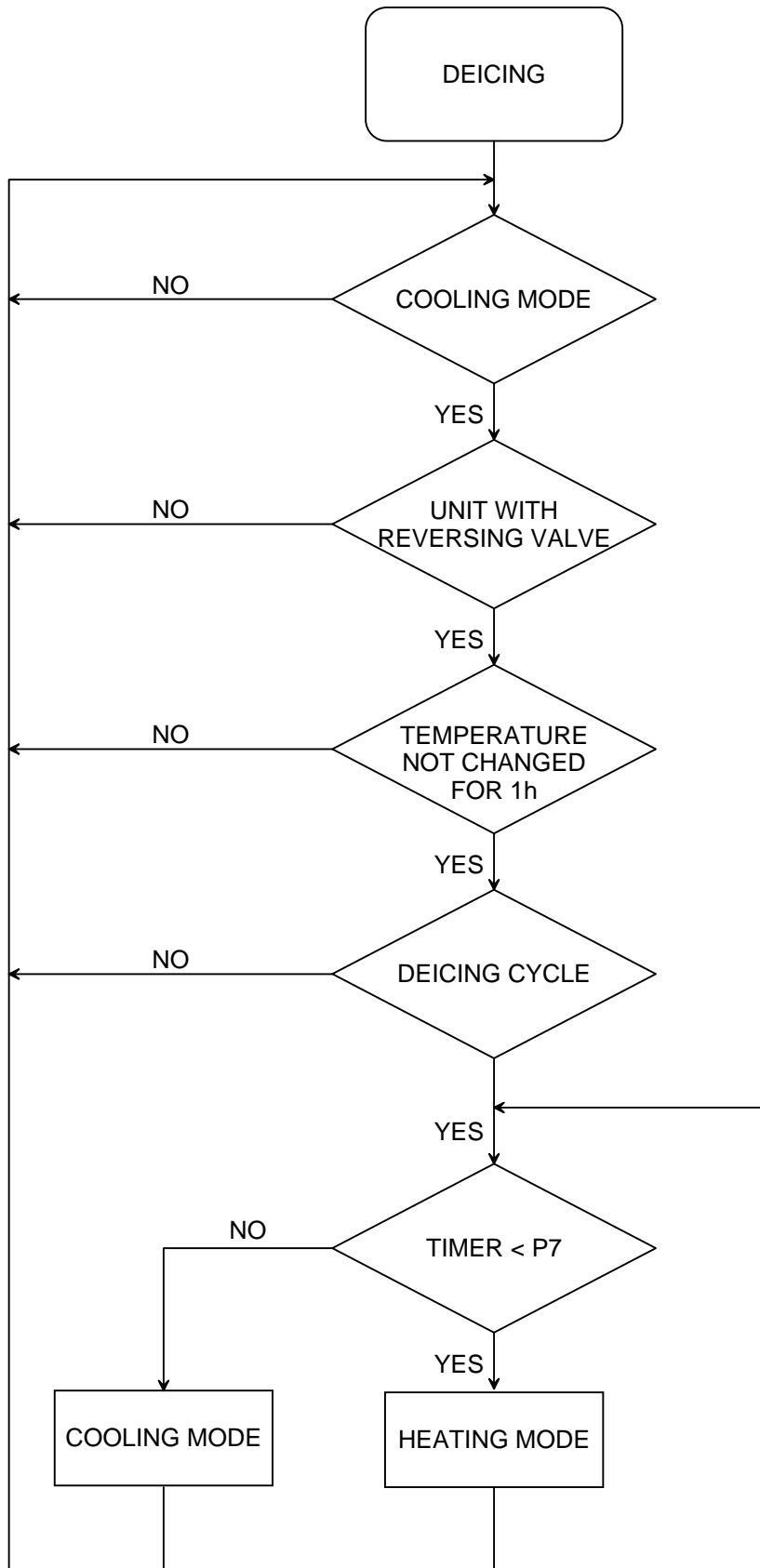

P7 REFERS TO PROGRAMMABLE PARAMETER P7

LP - HP - LA ALARM (P5)

P5 REFERS TO PROGRAMMABLE PARAMETER P5
LP Low Refrigerant Pressure Fault
HP High Refrigerant Pressure Fault
LA Low Input Voltage

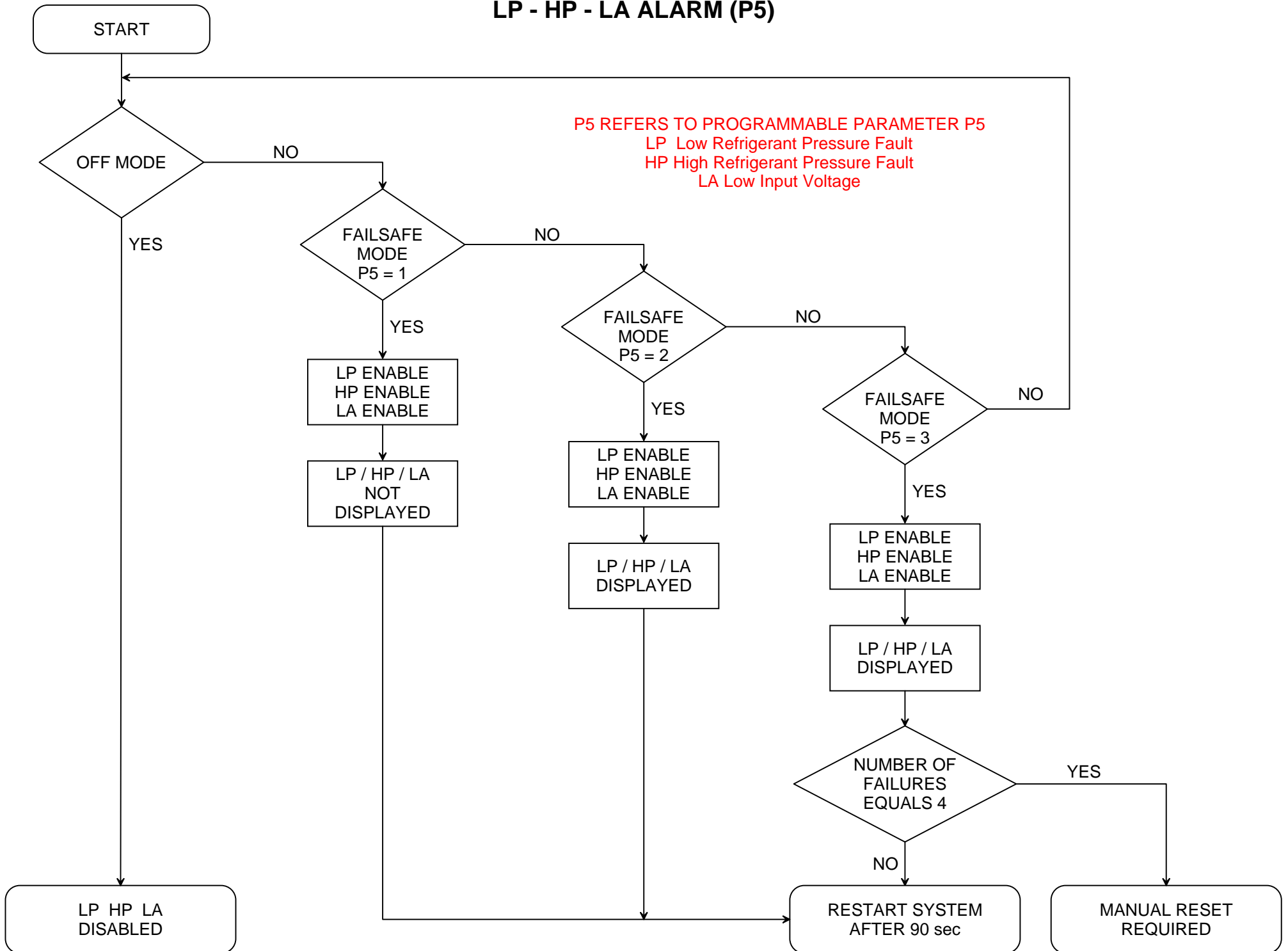

TERMINAL BLOCK - ENLARGED VIEW

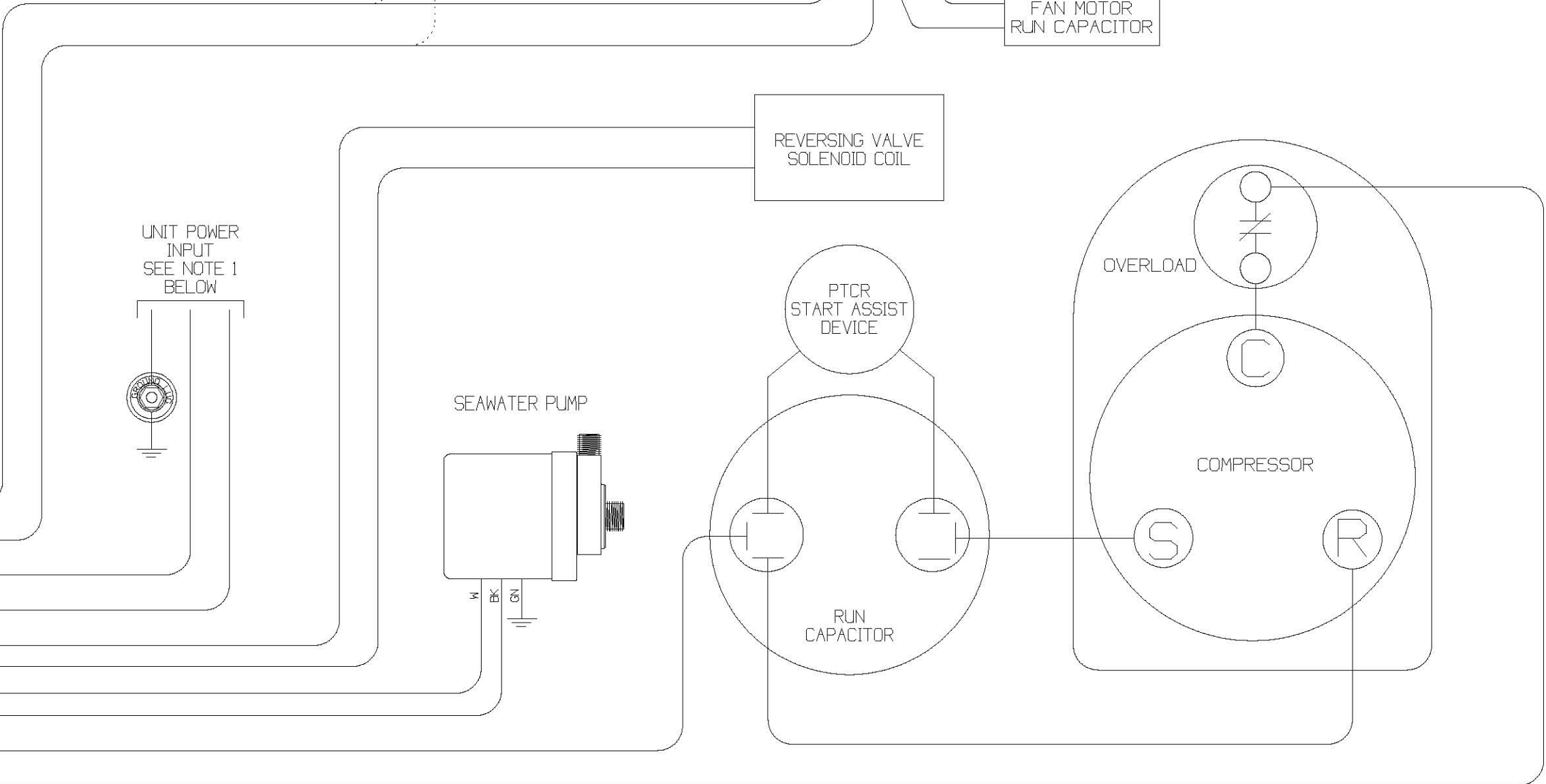
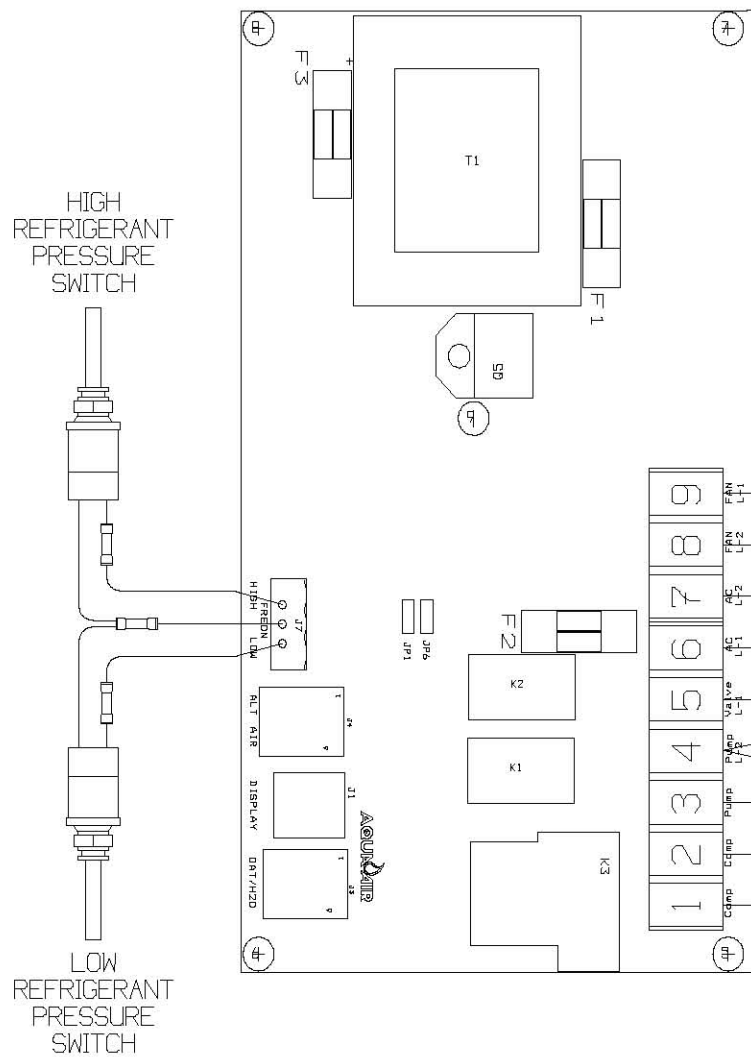
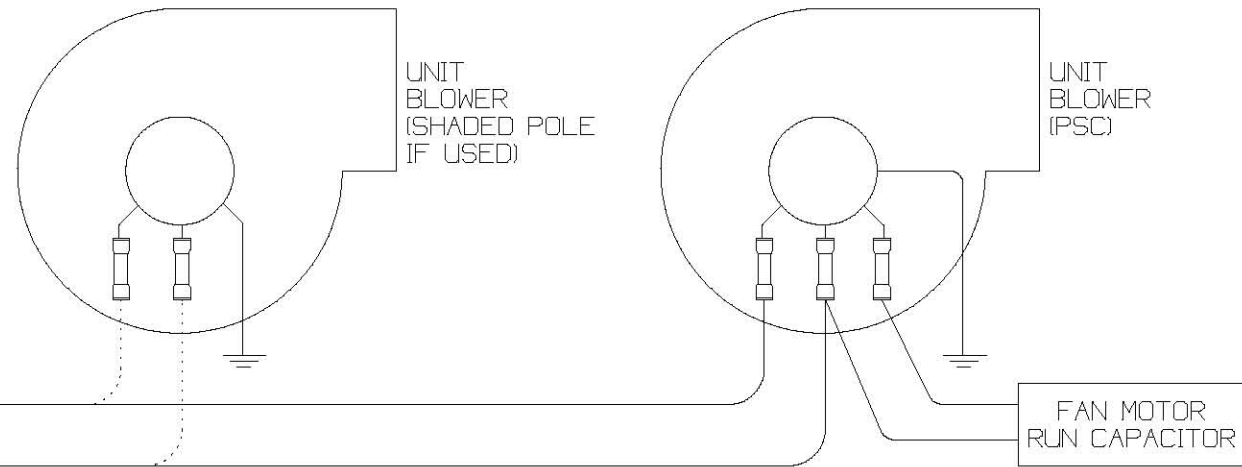
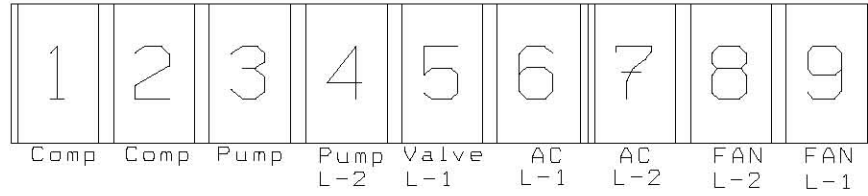

NOTE 1 POWER INPUT

VOLTAGE	TERMINAL		GRND
	6	7	LUG
115	L	N	G \perp
230	L1	L2	G \perp

AQUA-AIR MARINE AIR CONDITIONING SYSTEMS

SELF CONTAINED UNIT WIRING WITH SAPPHIRE DIGITAL THERMOSTAT (w/HIGH & LOW PRESSURE SWITCH)

DRAWING NUMBER	4010-03J	DRAWN BY	SB	DATE	08-11-08
SCALE	NONE	APPROVED BY	DN	REVISION DATE	

TERMINAL BLOCK - ENLARGED VIEW

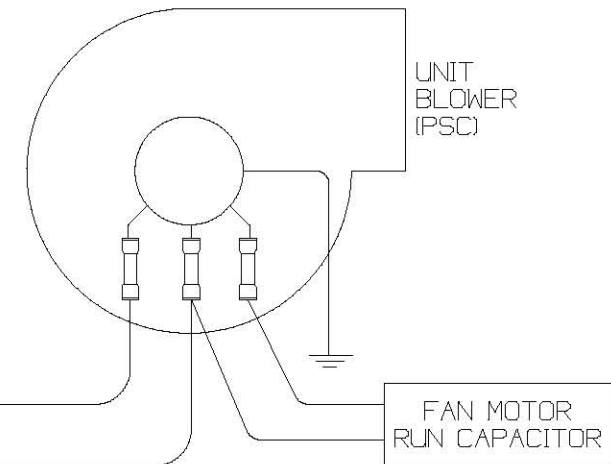
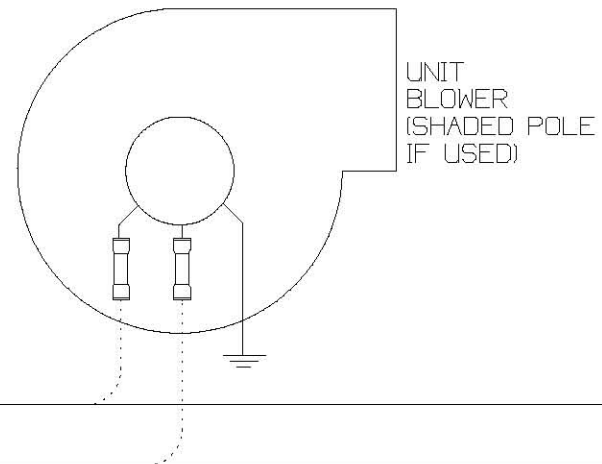
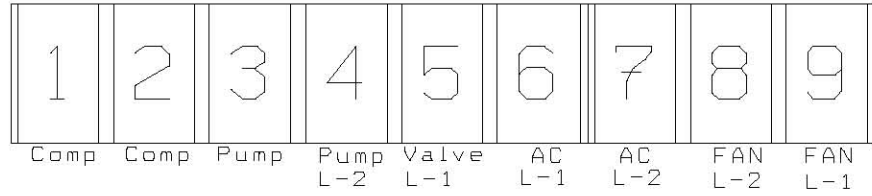

HIGH REFRIGERANT PRESSURE SWITCH

FAN MOTOR RUN CAPACITOR

REVERSING VALVE SOLENOID COIL

UNIT POWER INPUT
SEE NOTE 1 BELOW

SEAWATER PUMP

PTCR START ASSIST DEVICE

RUN CAPACITOR

OVERLOAD

COMPRESSOR

S

R

HIGH PRESSURE JUMPER

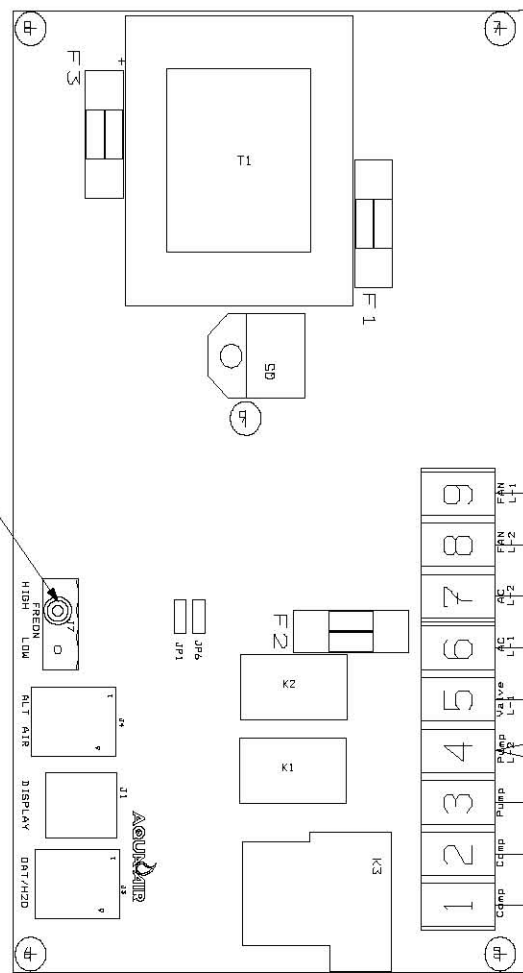

NOTE 1 POWER INPUT

VOLTAGE	TERMINAL		GRND
	6	7	LUG
115	L	N	G \perp
230	L1	L2	G \perp

AQUA-AIR MARINE AIR CONDITIONING SYSTEMS

SELF CONTAINED UNIT WIRING WITH SAPPHIRE DIGITAL THERMOSTAT (w/HIGH PRESSURE JUMPER)

DRAWING NUMBER	4010-03K	DRAWN BY	SB	DATE	08-11-08
SCALE	NONE	APPROVED BY	DN	REVISION DATE	

TERMINAL BLOCK - ENLARGED VIEW

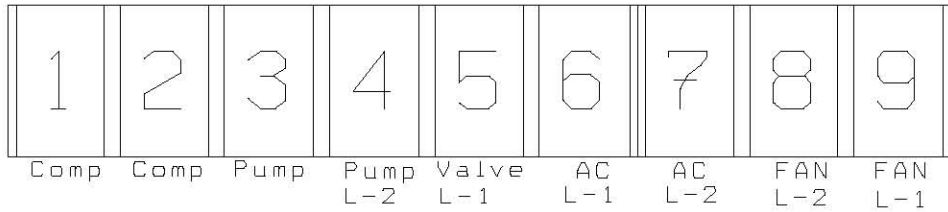

FAN COIL UNIT
VOLTAGE SAME AS SYSTEM VOLTAGE

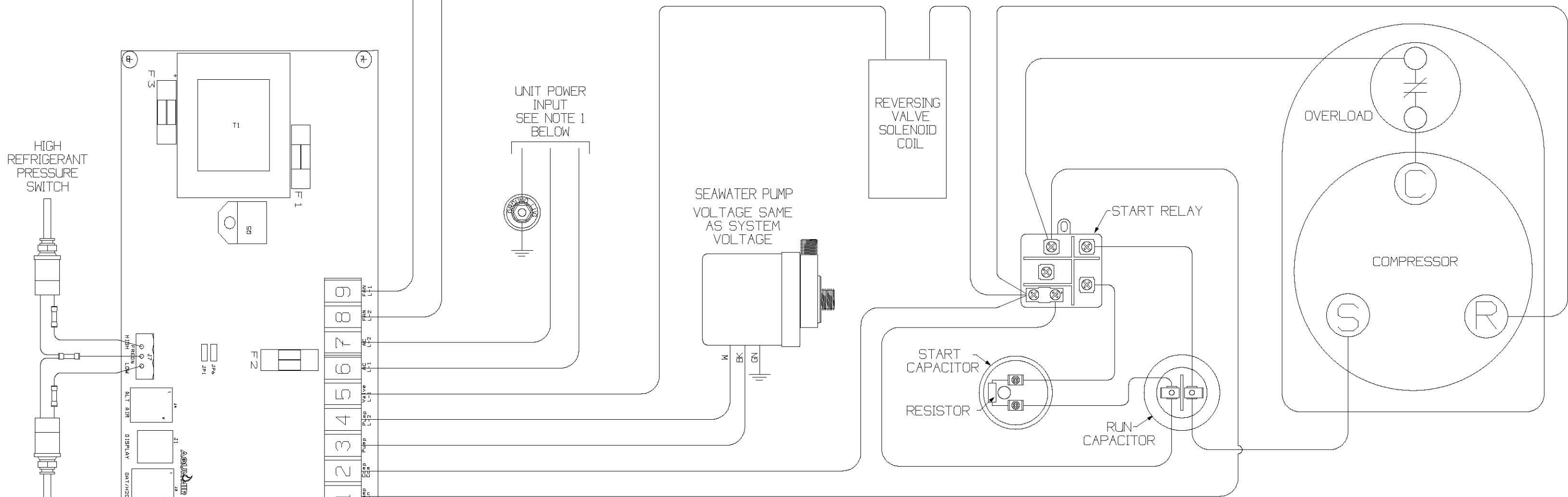

UNIT POWER INPUT
SEE NOTE 1 BELOW

SEAWATER PUMP
VOLTAGE SAME AS SYSTEM VOLTAGE

NOTE 1 POWER INPUT

VOLTAGE	TERMINAL		GRND
	6	7	LUG
115	L	N	G \perp
230	L1	L2	G \perp

AQUAIR MARINE AIR CONDITIONING SYSTEMS

CONDENSING UNIT WIRING WITH SAPPHIRE DIGITAL THERMOSTAT (w/HIGH & LOW PRESSURE SWITCH)

DRAWING NUMBER	4009-47D	DRAWN BY	SB	DATE	08-11-08
SCALE	NONE	APPROVED BY	DN	REVISION DATE	

TERMINAL BLOCK - ENLARGED VIEW

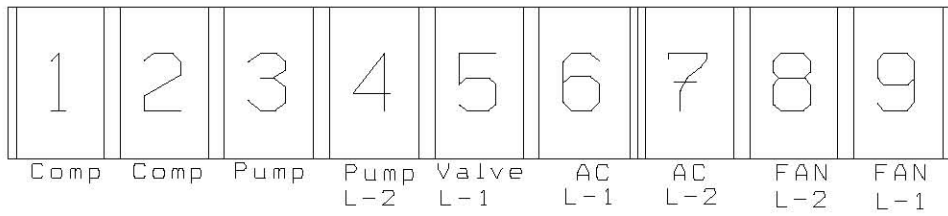

FAN COIL UNIT
VOLTAGE SAME AS SYSTEM
VOLTAGE

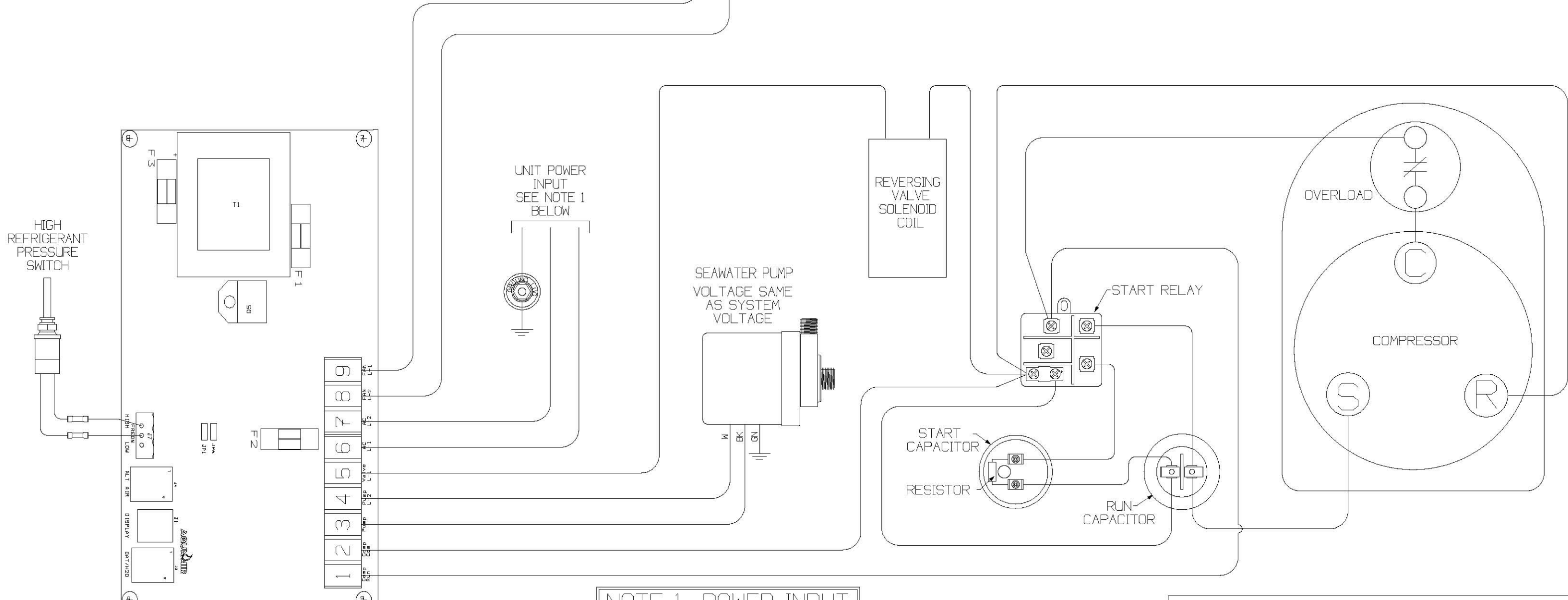

UNIT POWER INPUT
SEE NOTE 1 BELOW

SEAWATER PUMP
VOLTAGE SAME AS SYSTEM
VOLTAGE

NOTE 1 POWER INPUT			
VOLTAGE	TERMINAL		GRND
	6	7	LUG
115	L	N	G \perp
230	L1	L2	G \perp

AQUA-AIR MARINE AIR CONDITIONING SYSTEMS

CONDENSING UNIT WIRING WITH SAPPHIRE DIGITAL THERMOSTAT (w/o LOW PRESSURE SWITCH)

DRAWING NUMBER	4009-47E	DRAWN BY	SB	DATE	08-11-08
SCALE	NONE	APPROVED BY	DN	REVISION DATE	

TSV COMPONENT DIMENSIONS

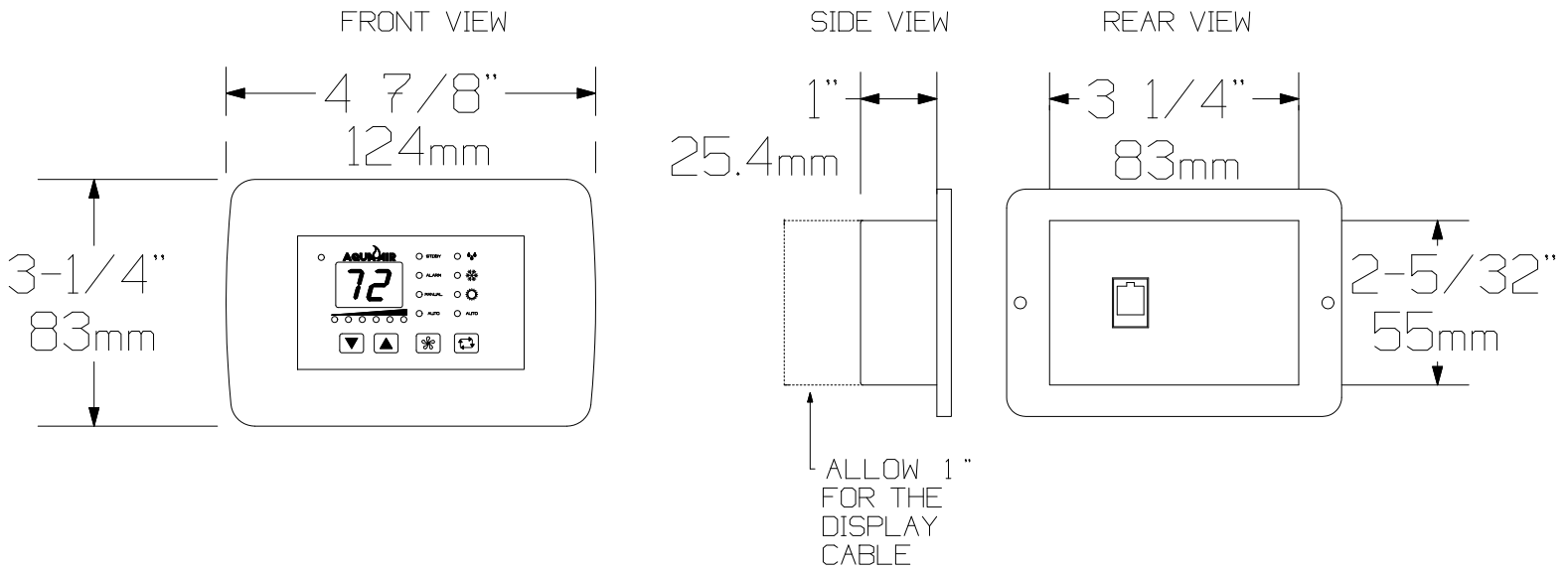

TSV-01 DISPLAY

TSV-02 CONTROL MODULE

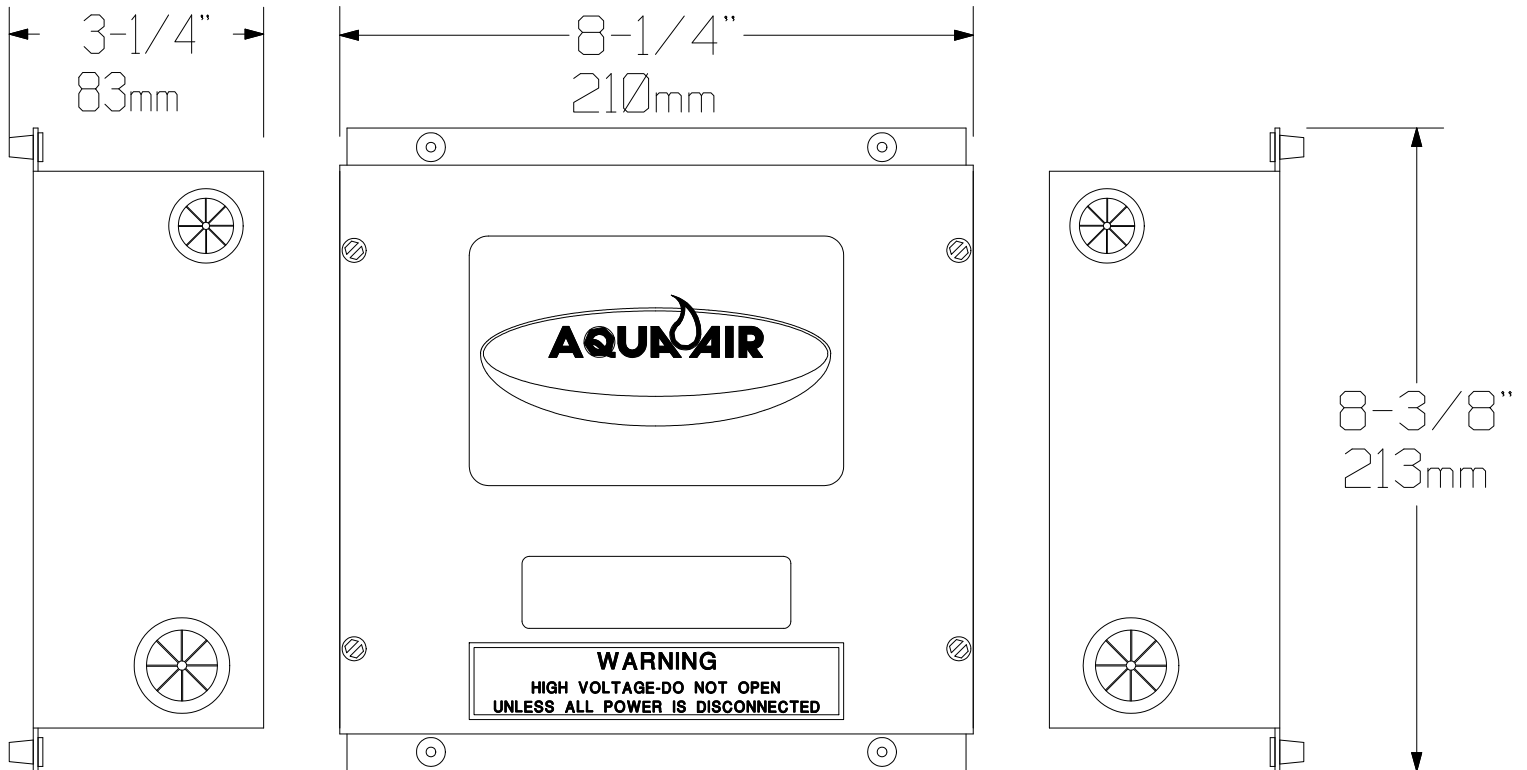

TWS DIGITAL THERMOSTAT COMPONENT DIMENSIONS

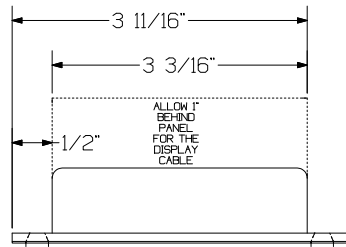

TWWS-01
DISPLAY HEAD

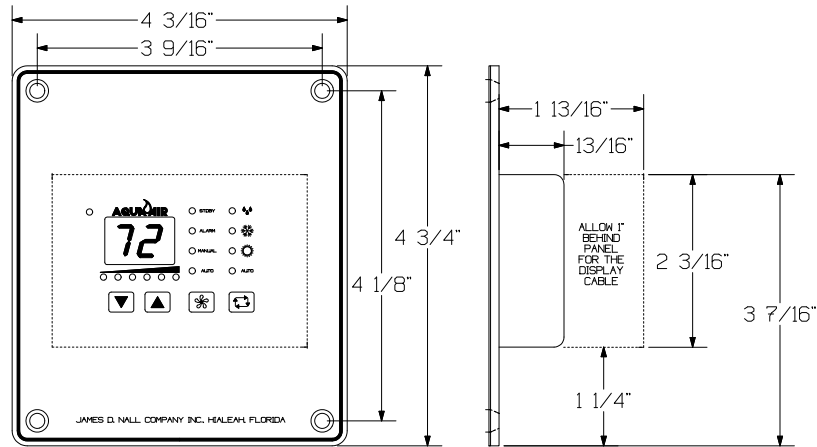

TSV-02 CONTROL MODULE

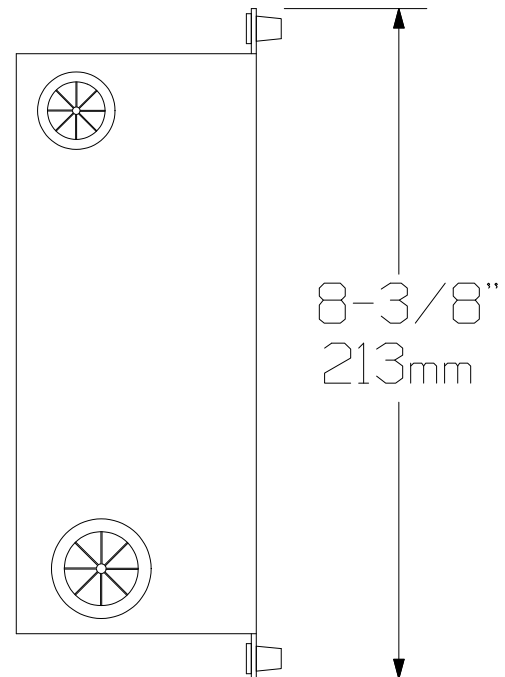
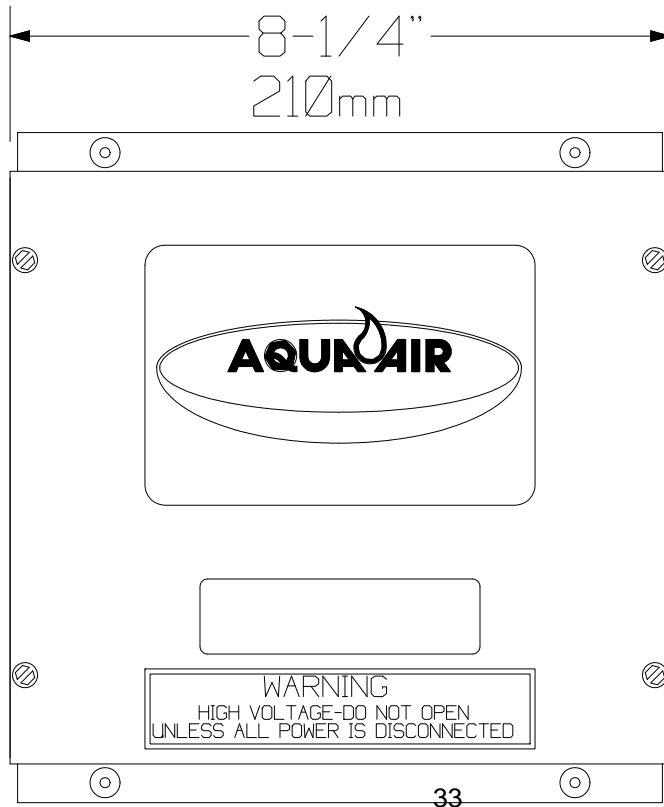
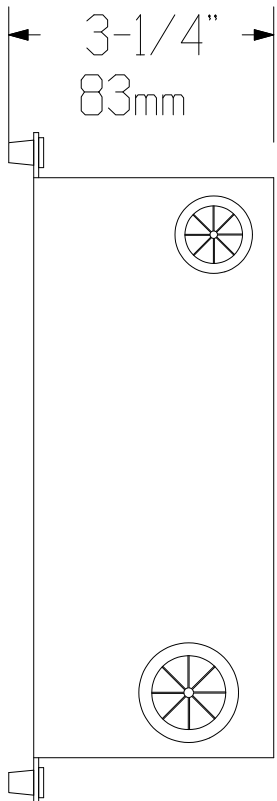

TEMPLATES FOR THERMOSTATS



J:/GXD/TEMPLATE

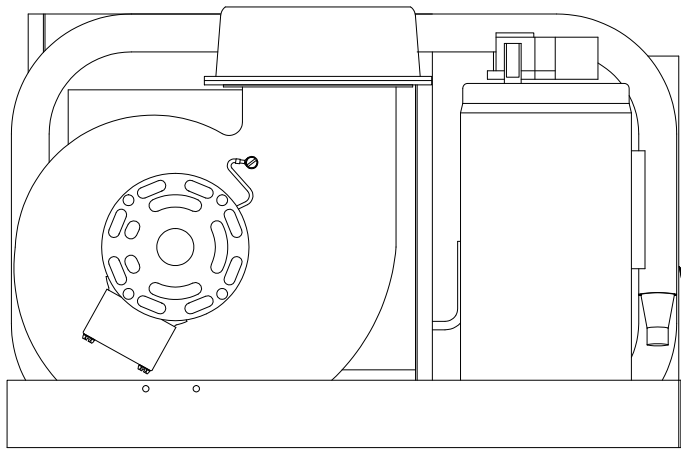

SELF CONTAINED UNIT
5-24,000 BTU/H
115 or 230V

WIRE COLORS

W WHITE
BK BLACK
G GREEN

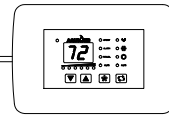
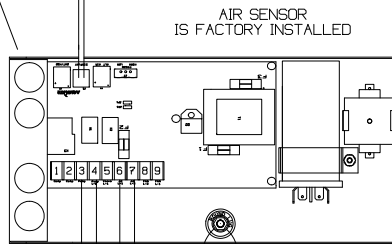

TSV-01
DIGITAL
THERMOSTAT
DISPLAY HEAD

OR

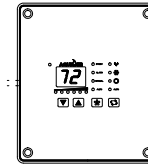

TWWS-01
DIGITAL
THERMOSTAT
DISPLAY HEAD

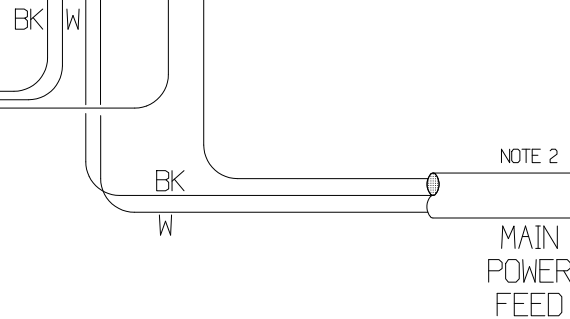
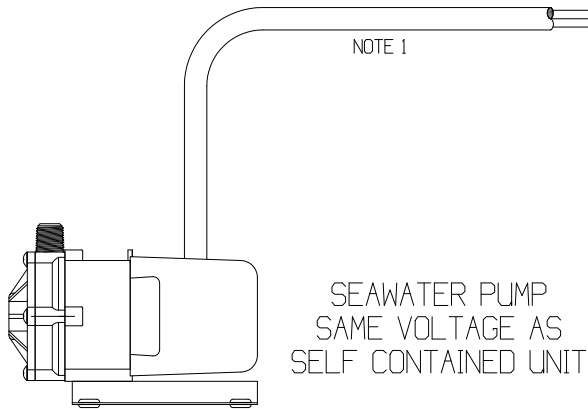

SYSTEM VOLTAGE

	115v	230v
G	GROUND	GROUND
BK	LINE	LINE 1
W	NEUTRAL	LINE 2

CONNECT TO SHIP'S
CIRCUIT BREAKER PANEL
TO PROPERLY SIZED
CIRCUIT BREAKER

NOTE (1): WIRE FOR ALL AQUA-AIR 'AQPM' SERIES PUMPS SHOULD BE 16 GA MINIMUM
NOTE (2): WIRE SIZE SHOULD BE ACCORDING TO CHART IN SELF CONTAINED UNIT
INSTALLATION MANUAL.
NOTE (3): ALL WIRING SHOULD BE DONE ACCORDING TO ABYC MANUAL SECTION E-8

AQUA-AIR		MARINE AIR CONDITIONING SYSTEMS	
SSR-05 TO 24 EXTERNAL WIRING CONNECTIONS w/ TSV-01 or TWWS-01 DISPLAY HEAD			
DRAWING NUMBER	4010-03AS	DRAWN BY	DN
		DATE	090427
SCALE	NONE	APPROVED BY	REVISION DATE
			REV A

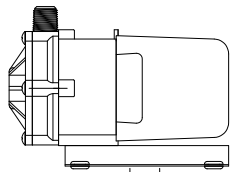

SEAWATER PUMP
SAME VOLTAGE
AS SYSTEM VOLTAGE

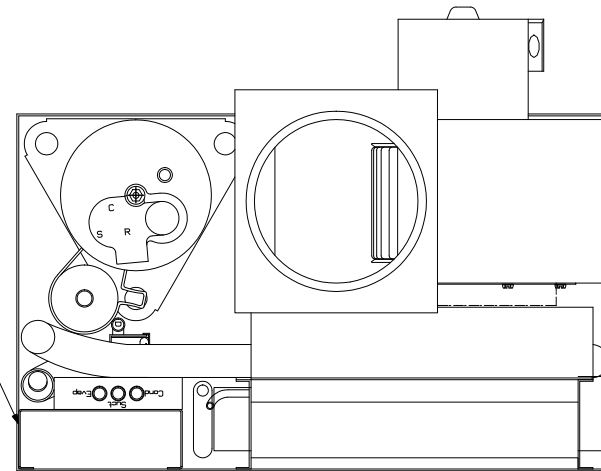

SELF CONTAINED UNIT
5-24,000 BTUH
115 or 230V

LOCATION OF
TERMINAL STRIP
INSIDE BOX

SYSTEM VOLTAGE

115v	230v	
GROUND	GROUND	G
LINE	LINE 1	BK
NEUTRAL	LINE 2	W

CONNECT TO SHIP'S
CIRCUIT BREAKER PANEL
TO PROPERLY SIZED
CIRCUIT BREAKER
FOR PUMP USED

WIRE COLORS

W	WHITE
BK	BLACK
G	GREEN

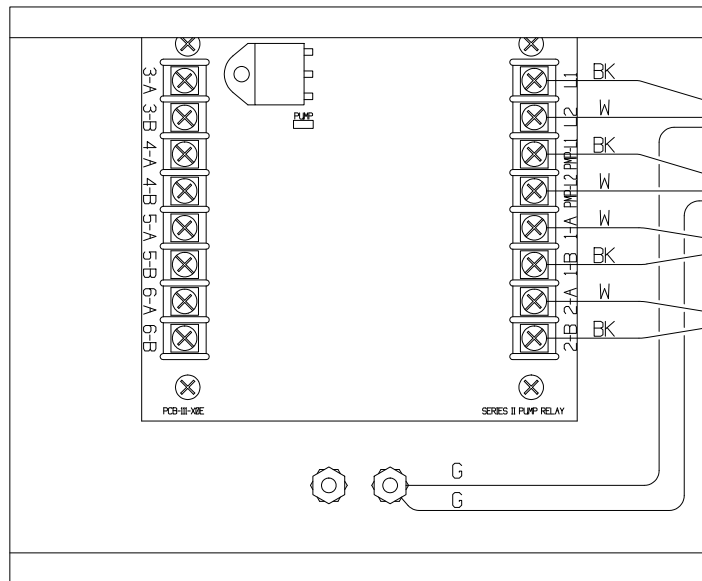

AQP6R PUMP RELAY

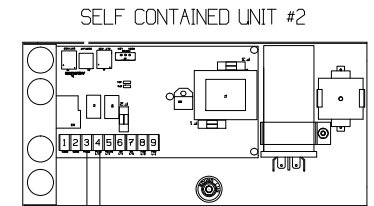
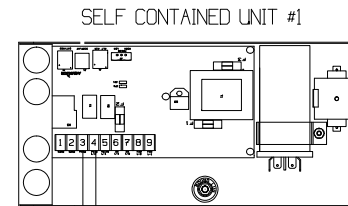

UP TO FOUR MORE SELF CONTAINED
UNITS CAN BE CONNECTED TO
THE AQP6R ON POSITIONS
3A/3B THRU 6A/6B

INPUTS CAN BE EITHER 115 or 230V

AQUA-AIR MARINE AIR CONDITIONING SYSTEMS			
AQP6R w/2 or MORE SELF CONTAINED UNITS SSR-05 thru 24			
DRAWING NUMBER	APPROVED BY	DATE	REVISION
4010-03CS	DN	090427	
SCALE	APPROVED DATE	REVISION DATE	REV
NONE	DN		A

SELF CONTAINED UNIT
5-24,000 BTUH
115 or 230V

AQS3 SERIES
THERMOSTAT

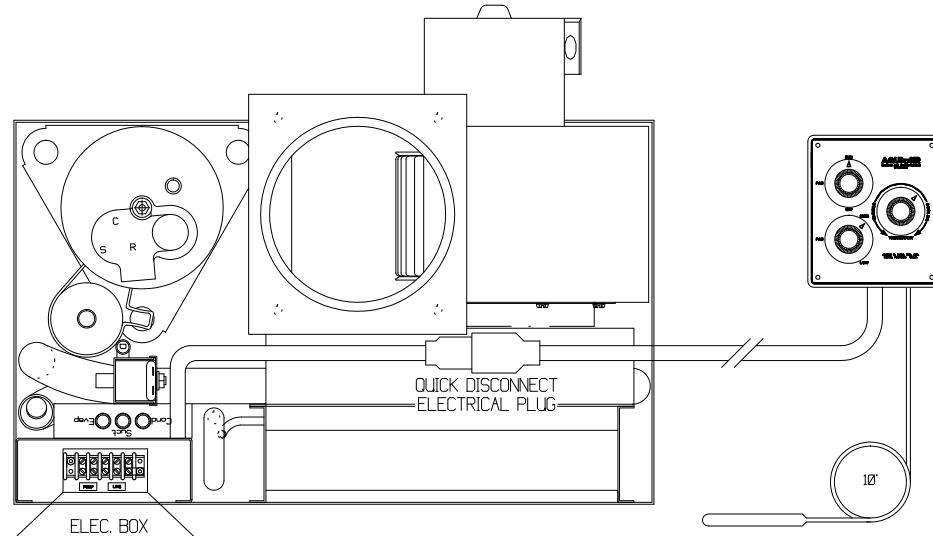

TEMPERATURE SENSING
BULB TO BE PLACED
IN THE RETURN AIR
FLOW TO THE SELF
CONTAINED UNIT

WIRE COLORS

W WHITE
BK BLACK
G GREEN
R RED

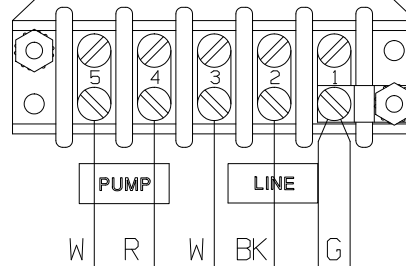

SYSTEM VOLTAGE

	115v	230v
G	GROUND	GROUND
BK	LINE	LINE 1
W	NEUTRAL	LINE 2

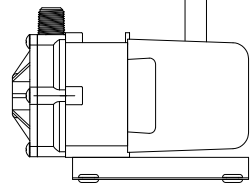

SEAWATER PUMP
SAME VOLTAGE AS
SELF CONTAINED UNIT

NOTE 1

NOTE 2

MAIN
POWER
FEED

CONNECT TO SHIP'S
CIRCUIT BREAKER PANEL
TO PROPERLY SIZED
CIRCUIT BREAKER

NOTE (1): WIRE FOR ALL AQUA-AIR 'AQPM' SERIES PUMPS SHOULD BE 16 GA MINIMUM
NOTE (2): WIRE SIZE SHOULD BE ACCORDING TO CHART IN SELF CONTAINED UNIT
INSTALLATION MANUAL.
NOTE (3): ALL WIRING SHOULD BE DONE ACCORDING TO ABYC MANUAL 49 SECTION E-8

AQUA-AIR		MARINE AIR CONDITIONING SYSTEMS	
SMR-05 to 16 & SMS-24C EXTERNAL WIRING CONNECTIONS w/AQS3 SERIES THERMOSTAT			
DRAWING NUMBER	4010-04A	DRAWN BY	DN
		DATE	090427
SCALE	NONE	APPROVED BY	
		REVISION DATE	
		REV	B

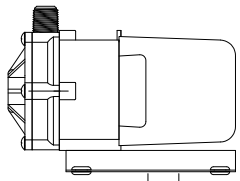

SEAWATER PUMP
SAME VOLTAGE
AS SYSTEM VOLTAGE

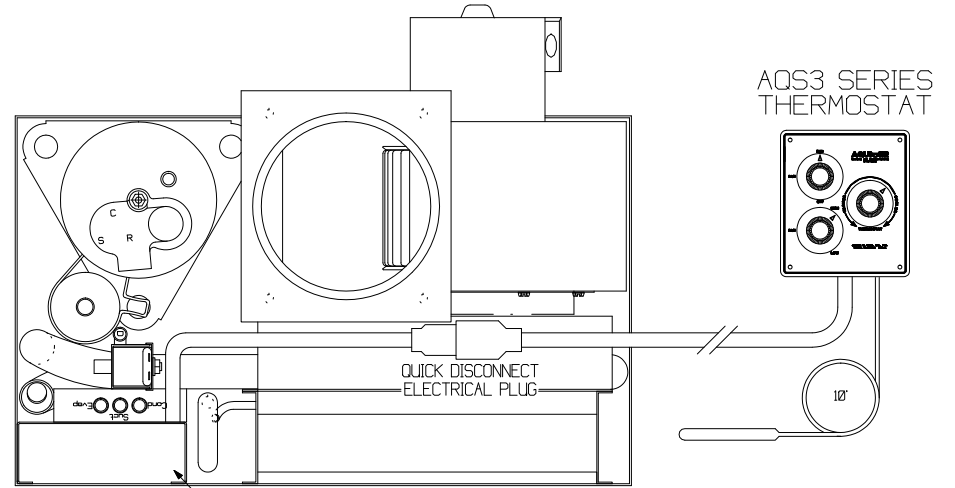

AQS3 SERIES
THERMOSTAT

QUICK DISCONNECT
ELECTRICAL PLUG

LOCATION OF TERMINAL
BLOCK ON EACH UNIT

SYSTEM VOLTAGE

115v	230v	
GROUND	GROUND	G
LINE	LINE 1	BK
NEUTRAL	LINE 2	W

CONNECT TO SHIP'S
CIRCUIT BREAKER PANEL
TO PROPERLY SIZED
CIRCUIT BREAKER
FOR PUMP USED

WIRE COLORS

W	WHITE
BK	BLACK
G	GREEN

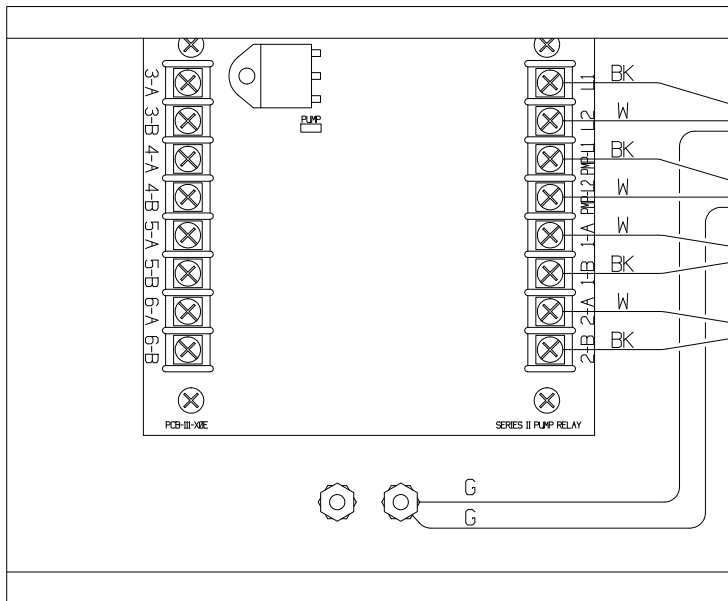

AQP6R PUMP RELAY

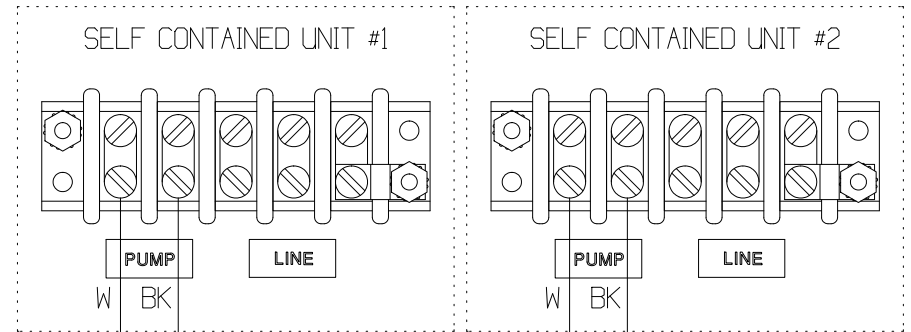

UP TO FOUR MORE SELF CONTAINED
UNITS CAN BE CONNECTED TO
THE AQP6R ON POSITIONS
3A/3B THRU 6A/6B

INPUTS CAN BE EITHER 115 or 230V

AQUA-AIR		MARINE AIR CONDITIONING SYSTEMS	
AQP6R w/ 2 or MORE SELF CONTAINED UNITS SMR-05 TO 24			
DRAWING NUMBER	4010-04C	DRAWN BY	DN
SCALE	NONE	DATE	090427
APPROVED BY		REVISION DATE	
		REV	B

REVISIONS			
REV.	DESCRIPTION	BY	DATE
B	DWG. MODIFIED TO SHOW NEW TW SAPPHIRE PCB & START ASSIST DEVICE.	CC	01-20-05

FOR OLD DWG. SEE DWG.#4010-03A

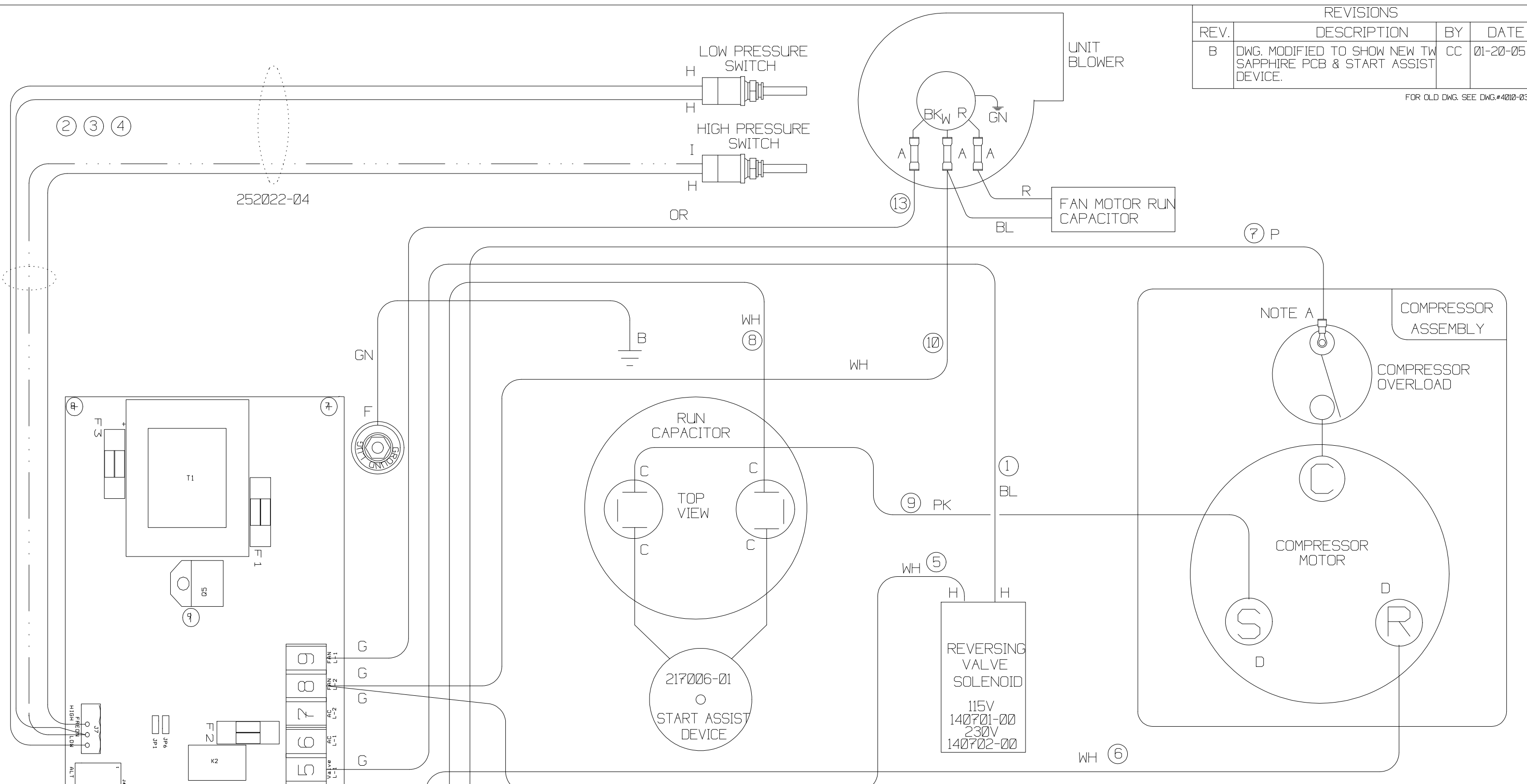

NOTES:

A. THE 222001-06 TERMINAL IS APPLICABLE FOR ALL UNITS 7-16KBTU. THE 24KBTU COMPRESSOR DOES NOT HAVE AN EXTERNAL OVERLOAD. THE WIRE CONNECTS DIRECTLY TO THE "C" POST ON THE COMP. WITH A 222004-01 TERMINAL.

- TERMINAL DESIGNATIONS:**
- A 222000-01 BUTT CONN.
 - B 222001-06 RING TERMINAL
 - C 222003-01 FEMALE .250"
 - D 222004-01 FEMALE FLAG
 - E 222003-02 FEMALE .250"
 - F 222002-03 FORK TERMINAL
 - G 222002-01 FORK TERMINAL
 - H 222003-05 FEMALE .250" INSUL
 - I 222002-06 FEMALE INSUL

AQUA-AIR MARINE AIR CONDITIONING SYSTEMS

SSR-05 thru 16 & SSS-24C
INTERNAL WIRING SCHEMATIC

DRAWING NUMBER	4010-03	DRAWN BY	DN	DATE	090427
SCALE	NONE	APPROVED BY		REVISION DATE	
					REV C

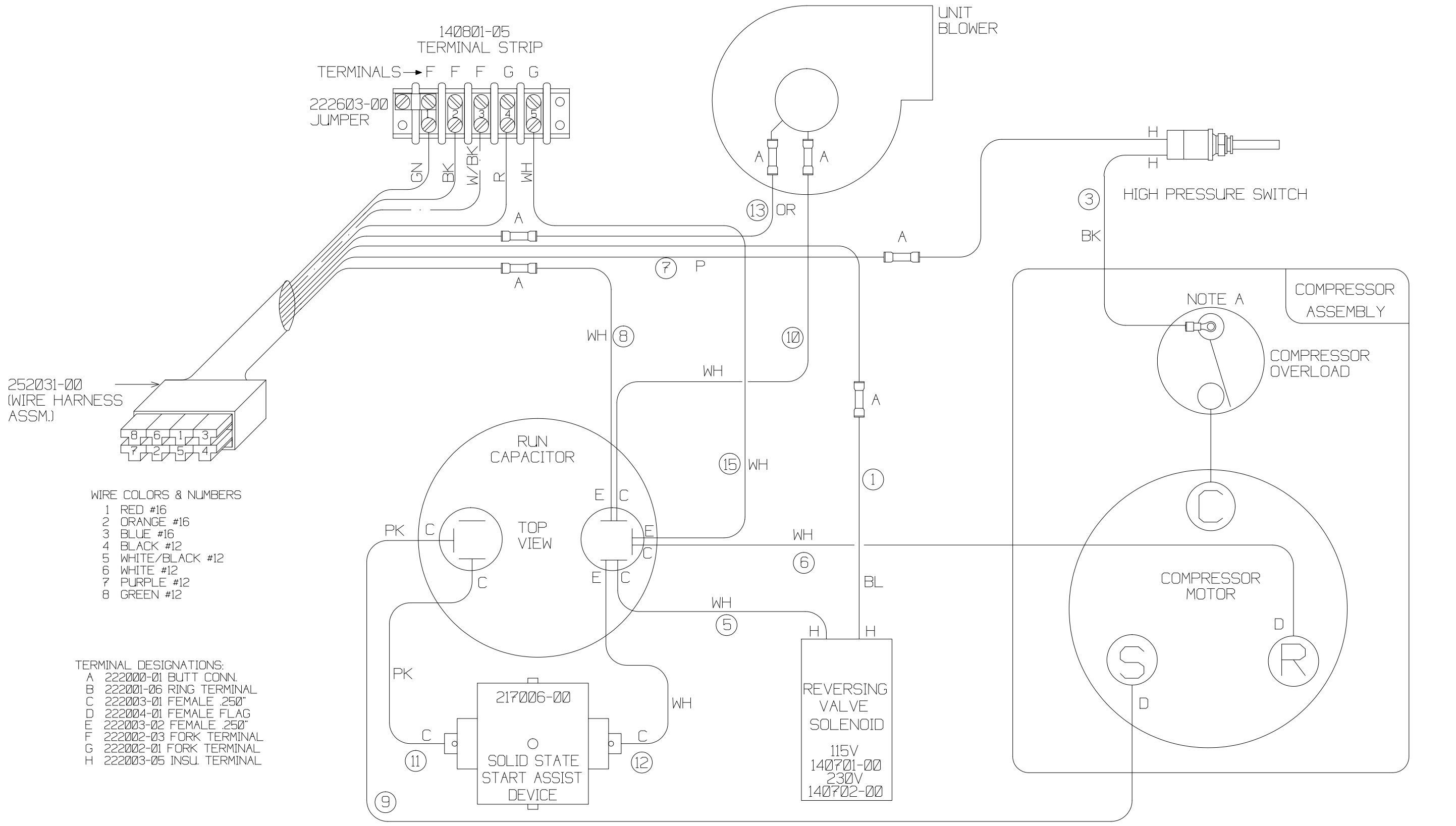

NOTES:

A. THE 222001-06 TERMINAL IS APPLICABLE FOR ALL UNITS 7-16KBTU. THE 24KBTU COMPRESSOR DOES NOT HAVE AN EXTERNAL OVERLOAD. THE WIRE CONNECTS DIRECTLY TO THE "C" POST ON THE COMP. WITH A 222004-01 TERMINAL.

AQUA-AIR		MARINE AIR CONDITIONING SYSTEMS	
SMR-05 TO 16 & SMS-24C INTERNAL WIRING SCHEMATIC			
DRAWING NUMBER	4010-04F	DRAWN BY	SB
DATE	090427	APPROVED BY	DN
SCALE	NONE	REVISION DATE	REV C



AQUA AIR

MARINE AIR CONDITIONING SYSTEMS

***AQUA-AIR MANUFACTURING, division of the James D. Nall Co., Inc.
1050 East 9th Street, Hialeah, Florida 33010 U.S.A.
Toll Free 800-328-1043 Local 305-884-8363 Fax 305-883-8549
Email sales@aquair.com www.aquair.com***

Copyright 2009 Aqua-Air Manufacturing, All rights reserved

Every effort has been made to ensure that the information included in this manual is complete and accurate. However, Aqua-Air Manufacturing, division of the James D. Nall Co., Inc. assumes no responsibility for errors or omissions. Neither is any liability assumed for damages resulting from the use of this product and the information contained herein.