

AQUA AIR

MARINE AIR CONDITIONING SYSTEMS

Direct Expansion Split Marine Air Conditioning System

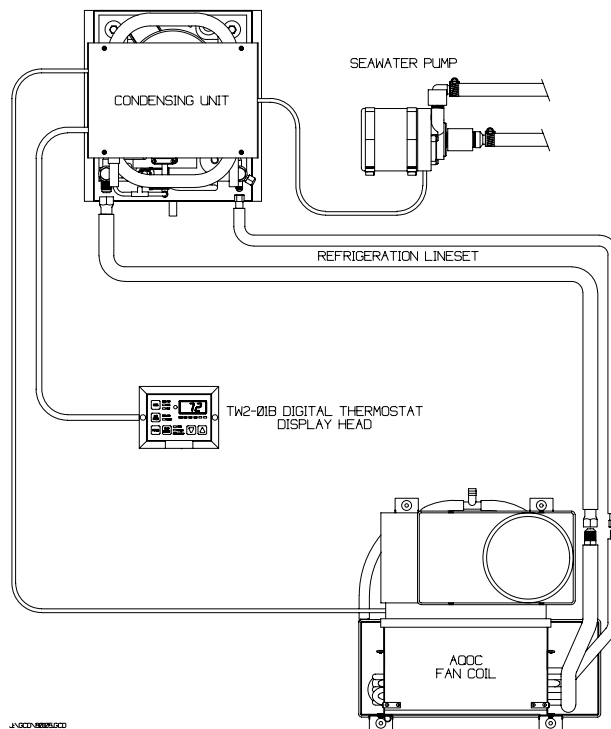

Installation, Operation & Maintenance

Table of Contents

I	Introduction	4
II	General Description of Basic Components	
	A. Fan Coil	4
	B. Condensing Unit	5
	C. Thermostats	5
	D. Seawater Pump	7
	E. Pump Relays	8
	F. Ducting, Grilles & Transition Boxes	8
	G. Seawater Kits	9
	H. Refrigerant Line Sets	9
	I. Basic Theory of System Operation	10
III	Installation of Basic Components	
	A. Fan Coil	12
	B. Condensing Unit	17
	C. Refrigerant Line Sets	18
	D. Flaring Copper Tubing	18
	E. Thermostats	19
	F. Seawater Pump	22
IV	Before Starting the System for the First Time	24
V	System Leak Checking and Refrigerant Charging	
	A. Leak Checking the System	25
	B. Charging the System with Refrigerant	27
	C. Recovering Refrigerant from the System	28
VI	System Operation	
	A. Systems with AQS3 Thermostats	28
	B. Systems with Tempwise 2001 Thermostats	29
	C. Reverse Cycle System Limitations	30
VII	Maintenance	
	A. Fan Coil	31
	B. Seawater System	31
VIII	Winterizing	32
IX	General Warnings	32
X	Thermostat Cut-out Templates	33
XI	Refrigerant Charging Charts	34
XII	Refrigerant Line Set Sizing and Refrigerant Tee Arrangements	35
XIII	System Wiring Diagrams	38

I. Introduction

Thank you for purchasing an Aqua-Air® Direct Expansion Split Marine Air Conditioning System.

The purpose of this manual is to inform you of the different components that you will need to install a fully operational direct expansion split air conditioning system on your boat and to give you the basic information necessary to correctly install all of the components that comprise the direct expansion split air conditioning system.

The Aqua-Air® direct expansion split air conditioning system have been specifically designed for use in the marine environment. Systems are available in a range of capacities from 5-48,000 BTU/H in either 115/1/60 or 230/1/60 voltage inputs (the 24-48,000 BTU/H units are also available in 208-230/3/50-60 and 460/3/50-60). All systems are rated for full capacity on 60 Hz power, however, they can be operated on 50 Hz power sources with a corresponding 17% decrease in capacity. The 50 Hz power sources would normally be 100/1/50, 200-220/1/50, or 380/3/50. All of the systems are available as reverse cycle units.

II. General Description of Basic Components

There are six basic components that make up a typical Aqua-Air® marine self contained system:

- A. Fan Coil
- B. Condensing Unit
- C. Thermostat
- D. Seawater Pump
- E. Pump Relay
- F. Ducting, Grilles and Transition Boxes
- G. Seawater Kit
- H. Refrigerant Line Sets

Following is a description of each major component.

A. Fan Coil

The Fan Coil (also referred to as an evaporator or air handler) is a refrigerant to air heat exchanger located in the area that is to be either cooled or heated. The basic unit is made up of the following major components:

- 1. Evaporator coil
- 2. Capillary tube refrigerant metering device
- 3. Squirrel cage blower and motor or propeller fan blade and motor
- 4. Metal chassis with integral drain pan

There are two different fan coil configurations, defined only by the direction that the air passes through the fan coil.

1. Blow-thru Fan Coil - air is blown across the evaporator coil
Examples: AQB, AQBH, AQE, AQL
2. Draw-thru Fan Coil - air is drawn across the evaporator coil
Examples: AQO, AQOC, AQOH, AQC

B. Condensing Unit

The Condensing Unit is made up of the following major components:

1. Refrigerant compressor
2. Suction accumulator
3. Reversing valve (if it is a heat pump model)
4. Base valves with service ports
5. Condenser
6. Electrical starting components for the compressor
7. Drain pan & mounting base

C. Thermostat

The thermostat / controller used to operate the unit can be provided in one of four different configurations:

1. Three knob manual thermostat (AQS3 series thermostat). The thermostats main components are:

Off-Fan-Run mode switch
Fan speed control
Thermostat
Terminal block

Fig. 1

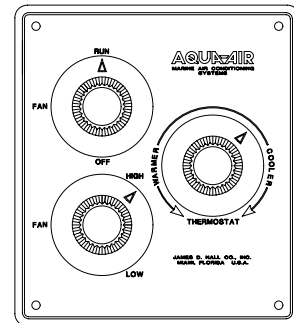

This thermostat is mounted in the area to be cooled/heated within 10' of the fan coil so that the air sensing bulb will be in the return air flow.

2. Tempwise 2001 digital thermostat (TW2D series). The thermostats main components are:

- Display Panel
- Control Module
- Display Cable

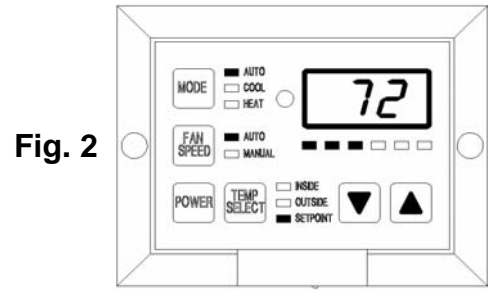

Fig. 2

This thermostat is mounted in the area to be cooled/heated. The control module should be mounted close to the fan coil for ease of connecting the fan motor.

The thermostat is available with either a black (TW2DB) or white (TW2DW) display head. The display head has an internal air sensor.

3. Tempwise 2001 digital thermostat display head (TW2-01B or W) when used with the 'T' series condensing units. The thermostats main components are:

- Display Panel
- Control Module (factory mounted & pre-wired to the condensing unit)
- Display Cable

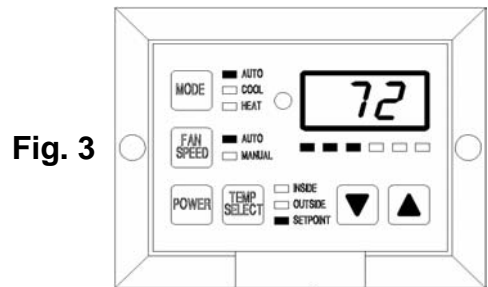

Fig. 3

The display panel and display cable are the only items that need to be installed as the control module is already mounted on the condensing unit. The display head has an internal air sensor.

The display panel is available in either black (TW2-01B) or white (TW2-01W). The display head has an internal air sensor.

D. Seawater Pump

The seawater pump is used to circulate seawater through the condenser on the condensing unit(s). These are all centrifugal pumps and are NOT self priming. This makes it necessary for the pump to be mounted below the ships running water line (under all conditions).

A condensing unit requires approximately 250 GPH (946 LPH) for every 12,000 BTU/H in capacity. Table 1 summarizes the amount of water necessary for a given capacity.

Fig. 4

CP-05
Seawater
Pump

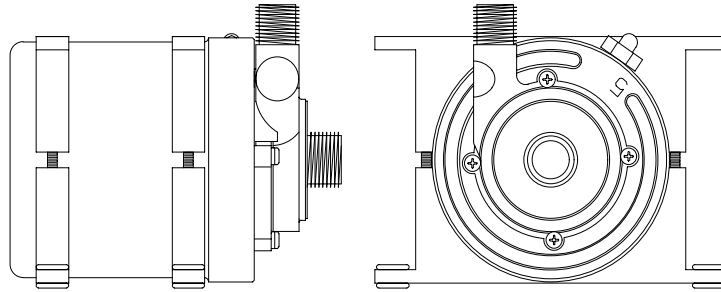

Condensing Unit Required Seawater Flow Rates		
Unit Capacity, BTU/H	Seawater Flow in GPH / LPH	Seawater Pump
5,000 to 12,000	250 / 946	CP-02
12,001 to 24,000	500 / 1,892	CP-05
24,001 to 48,000	1,000 / 3,784	CP-10
48,001 to 72,000	1,500 / 5,677	CD100B-36-03C
72,001 to 144,000	3,000 / 11,353	CD100B-40-05C

Table 1

E. Pump Relays

A pump relay is necessary when two or more condensing units are supplied water from a single seawater pump. Aqua-Air® offers three different pump relays:

- AQP2R** Designed for use with two condensing units and one seawater pump. Both condensing units must be on the same shore line. No external power source is needed. This relay is not ignition protected and therefore must not be used on a gasoline powered boat.
- AQP6R** This relay is a solid state module which will control a single seawater pump from as many as six separate condensing units. This relay requires an external power source. Because it is solid state it is ignition protected.
- AQP8R** This relay is a solid state module which will control a single seawater pump from as many as eight separate condensing units. A separate trigger (PEC-115 or 230) must be installed in the relay for each condensing unit used. This relay requires an external power source. Because it is solid state it is ignition protected.

F. Ducting, Grilles & Transition Boxes

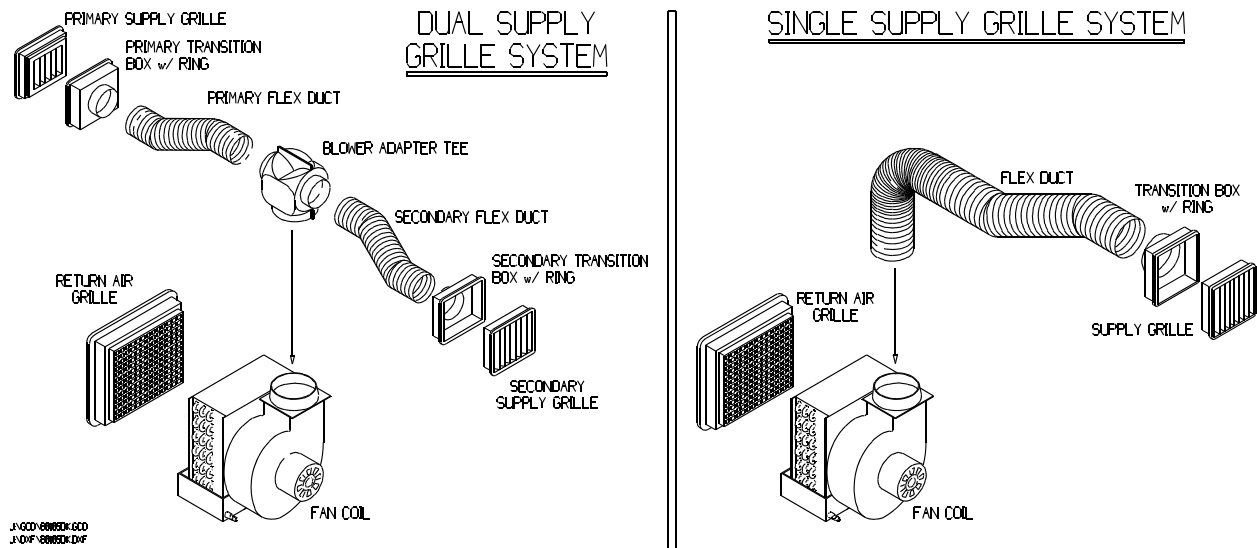

Figure 5 Duct Kit Components

To transfer the air flow from the fan coil to the area that you want to heat or cool you will need insulated flex duct, supply and return grilles, grille to flex duct transition boxes and possibly adapter tees. These items can be purchased in kit form from Aqua-Air®. We offer the Economy Duct Kit series (DKE) which includes plastic grilles or the Premium Duct Kit series (DKP) which includes wood (teak) framed grilles.

A complete description of the duct kits is available in the DK Series Grille & Duct Kit brochure, # 81890.

G. Seawater Kits

All of the components necessary to install the seawater circuit (except the seawater pump itself) are included in a seawater kit. There are two kits available:

1. SWK-05 Seawater Kit for use with the CP-02 pump and a 5,000 BTU/H condensing unit.
2. SWKU Seawater Kit for use with the CP-02, 05 and 10 pumps and a single 7-24,000 BTU/H condensing unit.

Included in the kits are a seawater inlet thru hull with a speed scoop, ball valve, seawater strainer, overboard thru hull, 25' of hose, hose clamps and necessary PVC fittings to complete the average installation. See Aqua-Air® brochure "Seawater Kits / SWK Series" #80625 for a complete description of all of the components included in these kits.

H. Refrigerant Line Sets

A refrigerant line set is comprised of the following components:

1. Seamless, refrigerant grade, soft copper tubing
2. Tubing insulation
3. Wire
4. Flare nuts

Each line set is shipped in the length requested with the tubing insulation and flare nuts installed. If wire (either 14/3 or 6 conductor) is to be included it is bundled along with the tubing.

Condensing Unit Refrigerant Line Set Sizes			
Unit Capacity, BTU/H	Suction Line	Liquid Line	Line Set Series
5-12,000	3/8"	1/4"	LS12
16,000	1/2"	1/4"	LS16
20-24,000	1/2"	3/8"	LS24
30-36,000	3/4"	3/8"	LS36

Table 2

The LS series line set kits are available in a basic 10' length with 5' extensions up to a maximum total length of 50'.

I. Basic Theory of System Operation

Cooling Mode

Refrigerant is pumped from the condensing unit compressor as a high pressure, high temperature gas through the reversing valve to the seawater condenser. In the seawater condenser, the gas gives up (rejects) the heat acquired during compression and from the system load to the seawater passing through the condenser. As this heat is rejected to the water the gas changes state from a gas to a liquid. This liquid then passes through the condensing unit liquid line base valve to the refrigerant line set. The refrigerant line set then transports the liquid refrigerant to the fan coil capillary tube(s). The liquid refrigerant passes through capillary tube(s) where it experiences a decrease in pressure. As the lower pressure liquid refrigerant exits the capillary tube into the evaporator it begins to absorb the heat contained in the air that is drawn (or blown) across the evaporator by the squirrel cage blower (or propeller fan), thereby 'cooling' the air that is then blown into the room. As the refrigerant absorbs the heat from the air it begins to change state from a liquid back to a gas. This gas then passes back to the condensing unit through the refrigerant line set to the condensing unit suction base valve. It then passes through the the reversing valve and the suction accumulator back to the compressor where the cycle begins again.

Heating Mode

In the heating mode the reversing valve solenoid is energized by the thermostat and the solenoid changes position. This causes the flow of refrigerant to change (reverse). The evaporator in the fan coil is now the heat exchanger to reject the heat of the unit and the seawater condenser is used as the evaporator to absorb the heat that is available in the seawater. The hot gas from the compressor is pumped through the reversing valve to the condensing unit base valve. It is then transported to the evaporator coil (which now is acting as the refrigerant condenser) by the refrigerant line set. Air is drawn (or blown) across the evaporator coil and then blown into the room, producing the desired heating effect. As the refrigerant releases this heat to the air it changes state from a gas to a liquid refrigerant. Upon exiting the evaporator (condenser) the refrigerant passes through the capillary tube(s) where a drop in refrigerant pressure occurs. The liquid/gas mixture then passes through the refrigerant line set to the condensing unit base valve and into the condenser (which is now acting as the refrigerant evaporator). Here, the liquid refrigerant begins to absorb the heat of the water that is passing through the condenser (evaporator). As it absorbs this heat it begins to change state from a liquid to a gas. This gas then passes through the reversing valve and then the suction accumulator on its way back to the compressor where the cycle begins again.

The refrigerant circuits for cooling and heating are shown in Figure 6.

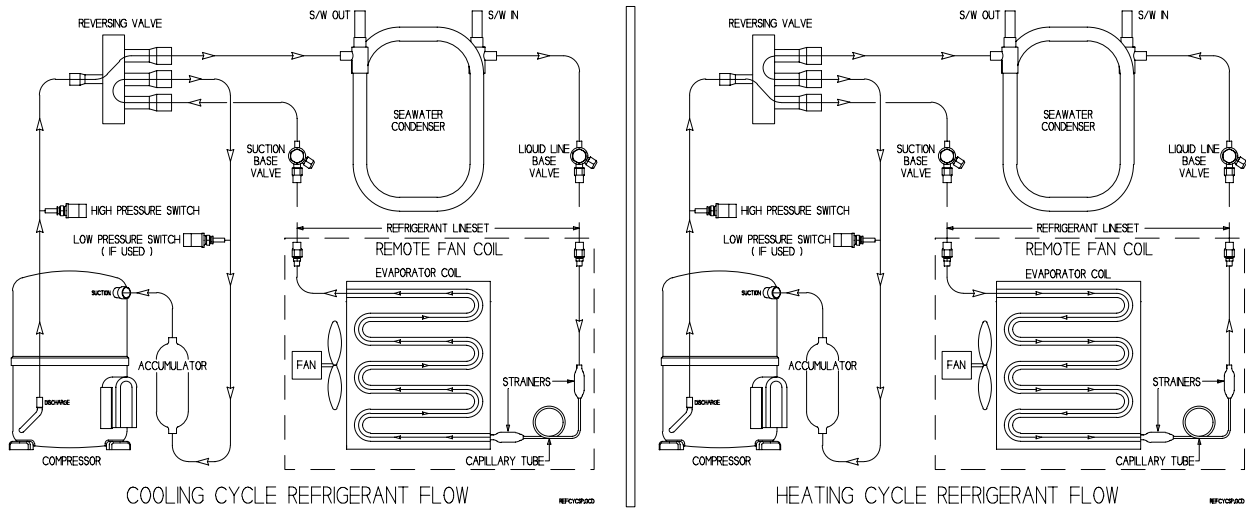

Figure 6 System Refrigerant Flow Diagram

III Installation of Basic Components

/ / / WARNING / / /

FAILURE TO COMPLY WITH THE INSTALLATION INSTRUCTIONS CONTAINED IN THIS MANUAL COULD PRODUCE HAZARDOUS CONDITIONS RESULTING IN THE INJURY OR DEATH OF THE OCCUPANTS AND THE DESTRUCTION OF THE BOAT. MAKE SURE THAT THE WARNINGS ON THE LAST PAGE OF THE MANUAL ARE FULLY UNDERSTOOD AND FOLLOWED.

ALL INSTALLATION TECHNIQUES SHOULD COMPLY WITH THE ABYC "STANDARDS FOR RECOMMENDED PRACTICES FOR SMALL CRAFT" SECTION A-6 and E-8.

IF THERE ARE ANY PARTS OF THIS MANUAL THAT ARE NOT CLEAR PLEASE CONTACT Aqua-Air® FOR FURTHER ASSISTANCE.

i i i i i

A. Fan Coils

Fan coils are ideally suited for installations in closets, under bunks or seats.

THEY SHOULD NEVER BE MOUNTED IN THE ENGINE ROOM OR BILGE AREA WHERE THEY COULD DRAW TOXIC FUMES INTO THE UNIT AND THEN DISCHARGE THEM INTO THE LIVING AREA.

In all applications the fan coil should be installed so that the air discharge is at least three feet above the floor. The best possible location is to have the air discharging at or near the ceiling level. The reason for mounting the air discharge as high as possible is because cold air is denser than ambient air and its natural tendency is to fall to the lowest point in the room after leaving the discharge grille.

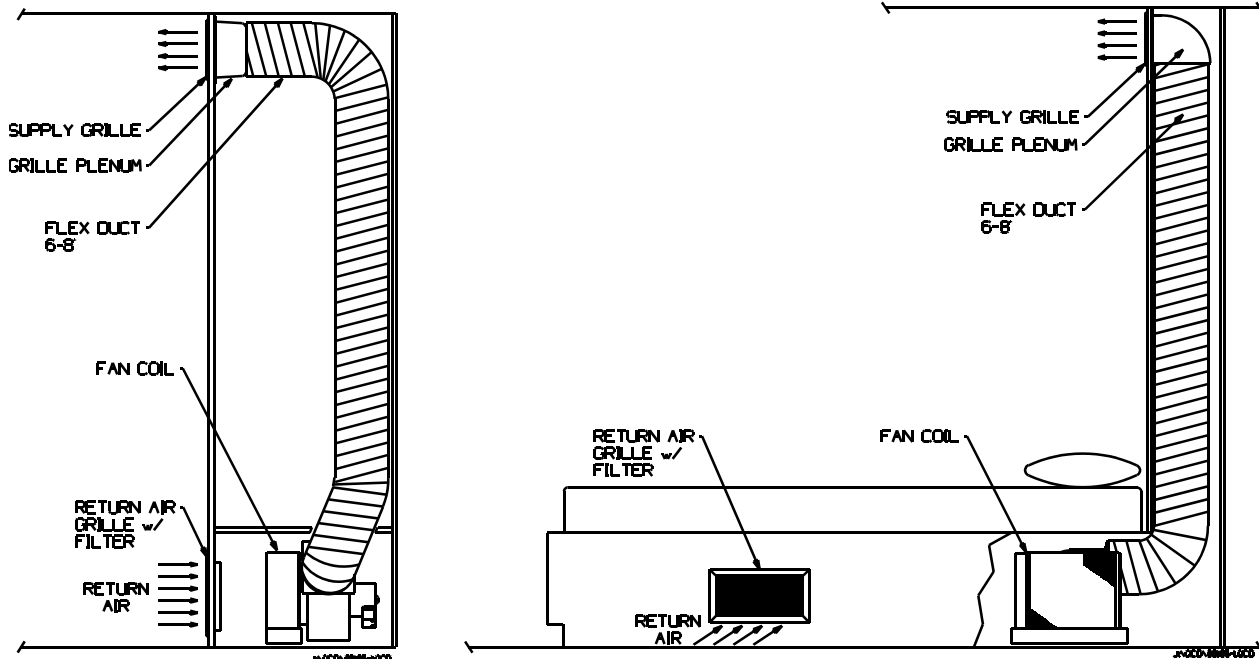

Figure 7 Typical Draw-Thru Fan Coil Installations

The unit must be mounted with the drain pan at the bottom of the unit as condensate from the evaporator is collected here. Each fan coil has two drain fittings that connect into a common tee. The drain line (minimum $\frac{1}{2}$ " ID) should be run either overboard or into a shower sump. It is not advisable to run the drain lines into the bilge where the condensate can become stagnant and foul smelling when mixed with seawater. On a hot, humid day several pints of water can be removed from the air by the self contained unit.

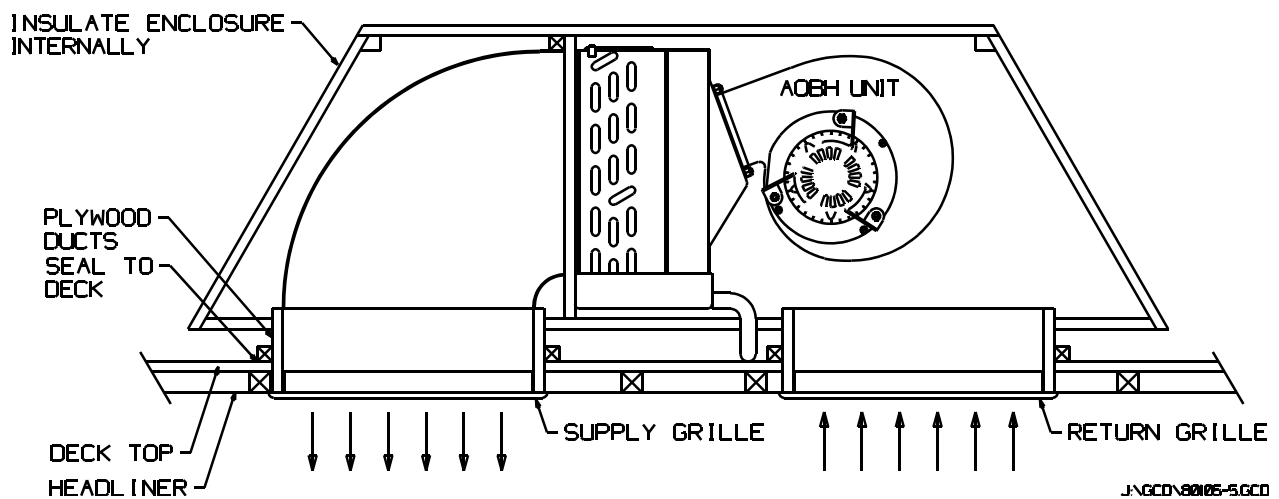

Figure 8 Overhead Blow-thru Fan Coil Installation

Insulated flex duct should be connected to the plastic blower discharge collar by first pulling back about two inches of the insulation on the end of the flex duct that you are going to attach to the blower. Slip the inner duct over the collar so that at least one of the duct reinforcing wires is up against the flat part of the collar. Install three sheet metal screws around the perimeter of the collar to hold the duct in place. Wrap a piece of duct tape around the duct that is on the collar. Slip the duct insulation back over the duct that is attached to the collar and duct tape in place.

The correct minimum grille sizes for each fan coil are shown in Table 2. Return air grilles can be larger than listed (this is one case where bigger is better), however, supply grilles should not be any larger than 25% over the recommended sizes. A supply grille that is too large will not properly disperse the air into the room causing hot spots. In either case the grilles must NOT be any smaller than the minimums listed. Small grilles cause decreases in system performance, fan coil icing or (in the heating mode) unit shut down due to high head pressures.

Minimum Grille and Flex Duct Sizes			
Model Number	Supply Grille in² / cm²	Return Grille in² / cm²	Minimum Duct Diameter, in/mm
AQO-04,5	32 / 206	64 / 412	4" / 100mm
AQO-07,8	40 / 258	72 / 464	5" / 125mm
AQO-10	48 / 309	100 / 645	5" / 125mm
AQO-12 AQOC-12 AQC-12	60 / 387	120 / 774	6" / 150mm
AQO-16 AQOC-16 AQC-16 AQC-16L	72 / 464	144 / 929	6" / 150mm
AQOH-20,24	120 / 774	200 / 1290	8" / 200mm
AQOH-30,36	160 / 1032	288 / 1858	10" / 250mm
AQB-04,5	8" x 8" 20cm x 20cm	64 / 412	NONE
AQB-07,8	8" x 8" 20cm x 20cm	72 / 464	NONE
AQB-10	10" x 10" 25cm x 25cm	100 / 645	NONE
AQB-12 AQBH-12	12" x 12" 30cm x 30cm	120 / 774	NONE

Minimum Grille and Flex Duct Sizes			
AQB-16 AQBH-16	12" x 12" 30cm x 30cm	144 / 929	NONE
AQL-12 AQE-12	8" x 16" 20cm x 40cm	120 / 774	NONE
AQL-16 AQE-16	8" x 16" 20cm x 40cm	144 / 929	NONE

Table 3

It is very important that there is adequate space for air to return to the fan coil. While the fan coil does not have to be directly behind the return air grille there must be an air path of the same area between the return air grille and the fan coil. Never mount the front of the fan coil any closer than two inches from a bulkhead as this will restrict the air flow into the unit.

A return air filter must be in place on the return air grille. This will prevent dirt and lint from being drawn into the fan coil, reducing performance. The most common type of filter material is an expanded aluminum type. This is the type used on all return air grilles supplied by Aqua-Air® that have return air filters. These filters should be checked on a monthly basis, during normal usage, and cleaned as necessary.

WARNING

TO AVOID AN ELECTRICAL SHOCK FROM A PIECE OF EQUIPMENT THAT HAS DEVELOPED AN INTERNAL SHORT ALWAYS GROUND ANY AQUA-AIR® SYSTEM IN THE MANNER DESCRIBED BELOW:

1. USE SUITABLE SIZED WIRE (SEE TABLE 4) WITH A GROUND WIRE TO FEED POWER TO:
 - a. AQS1 or AQS3 SERIES THERMOSTAT or
 - b. TEMPWISE 2001 THERMOSTAT or
 - c. CONDENSING UNIT EQUIPPED WITH A TEMPWISE or
 - d. CONDENSING UNIT WITH INTERNAL POWER RELAY
2. MAKE SURE THAT THE GROUND WIRE IS CONNECTED ON THE OTHER END AT THE CIRCUIT BREAKER PANEL.
3. CONNECT A GROUND WIRE FROM THE FAN COIL(S) TO THE THERMOSTAT GROUND LUG.
4. CONNECT A GROUND WIRE FROM THE SEAWATER PUMP TO THE GROUND LUG ON THE CONDENSING UNIT OR PUMP RELAY
5. CONNECT A GROUND WIRE BETWEEN THE PUMP RELAY (IF USED) AND CONDENSING UNIT GROUND LUG.
6. CONNECT A BONDING STRAP BETWEEN THE CONDENSING UNIT GROUND LUG AND THE SHIPS BONDING SYSTEM.
7. CHECK FOR CONTINUITY BETWEEN ALL OF THE ABOVE POINTS.
8. USE CORRECTLY SIZED WIRE TERMINALS FOR ALL CONNECTIONS. USE ONLY WIRE CRIMPING TOOLS THAT ARE MANUFACTURER APPROVED FOR THE WIRE TERMINALS USED.
9. ALL WIRING SHOULD COMPLY WITH THE ABYC "STANDARDS FOR RECOMMENDED PRACTICES FOR SMALL CRAFT" SECTION E-8.

**FAILURE TO COMPLY WITH THE ABOVE INSTRUCTIONS
CAN RESULT IN SERIOUS INJURY OR DEATH**

B. Condensing Units

The Aqua-Air® condensing units are designed for installation in almost any area of the boat. They are unaffected by moisture, vibration or ambient temperatures up to 140/ F (60/C). They should not, however, be installed in a location where they will be sprayed with seawater (such as under an engineroom air inlet). They are also designed to withstand the severe jolts that can be encountered by a boat when it is in a heavy sea. All of the refrigerant components are hermetically sealed.

The condensing units can be installed wherever there is sufficient space. Install the unit in a location where it is easily accessible for service. The plywood base that is at the bottom of the unit is not a shipping base. It is meant to stay on the unit to provide a means of securely fastening the unit down to whatever surface it is mounted on. Use a minimum of four screws to hold the unit in place. It should be fastened in such a way as to allow easy removal in case service is needed at a later date.

The condensing unit is connected to the seawater hoses coming from the seawater pump and going to the seawater overboard fitting. The hose should be (at a minimum) 5/8" ID, single braid hose. Insert the hoses on the seawater condenser tubes a minimum of 1-1/2" and clamp in place with a stainless steel hose clamp.

Connect a drain hose to the drain pan connection on the front of the condensing unit. This drain hose can then be run into a shower sump or overboard.

Connect the wiring from the condensing unit to the fan coil, thermostat, pump and/or pump relay and circuit breaker panel (when applicable) according to the correct wiring diagram for the system. Verify that all components are properly grounded and bonded.

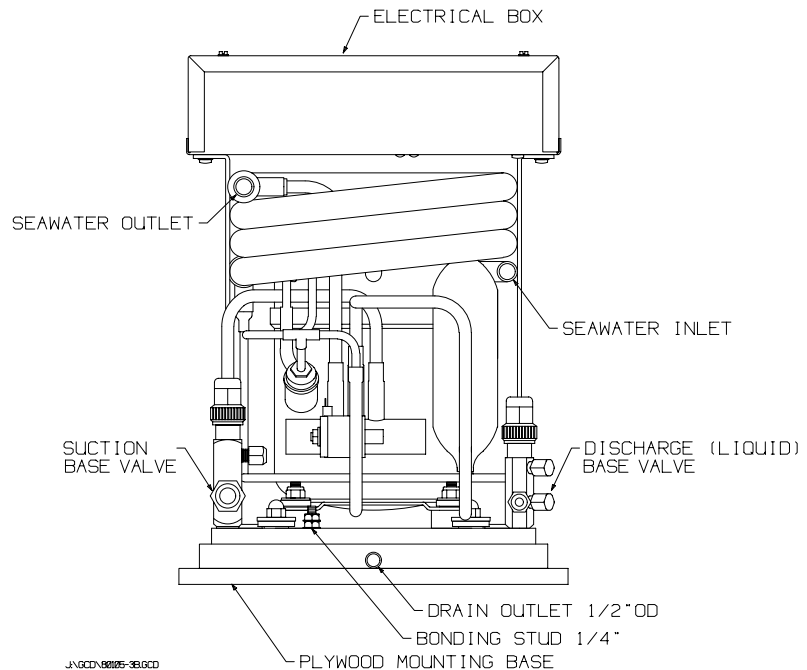

Figure 9 Typical Condensing Unit

C. Refrigerant Line Sets

When installing the connecting copper tubing between the condensing unit and the fan coil(s) several things must be kept in mind. The only type of copper tubing to use is refrigerant grade seamless soft copper. The maximum length of any line set is 50' (15.2m). The lines can be run in any manner i.e. up, down or at an angle. Try to avoid sharp bends as the tubing kinks easily.

Insulate both lines (suction and liquid) on reverse cycle systems and the suction line only on cooling only systems. Both refrigerant lines should never be insulated together in the same piece of insulation. When putting insulation on the copper lines tape the ends over to prevent anything that is in the inside of the insulation from entering the copper line. While running the lines throughout the boat the ends should remain taped over to prevent debris from entering the lines. All of the joints where the insulation meets should be taped to seal these joints. This will prevent condensation from forming on the outside of the line set.

The connections at the condensing unit and fan coil are made using flare fittings. These connections must be made with the greatest of care. The flare fittings that are used are of the 45°/single flare type. Double flares are not compatible with this type of flare joint and should never be used. When the flare is properly made it should be large enough in diameter to fill the inside of the flare nut.

D. Flaring Copper Tubing

Following is the accepted procedure for flaring copper refrigeration tubing for use with 45°/refrigeration flare fittings:

1. Use a copper tube tubing cutter to get a good square cut on the end of the tubing to be flared. Never cut the tubing with a hacksaw.
2. Ream the inside of the tube to remove any burrs. Make sure that none of the copper filings fall inside of the tube.
3. Place the flare nut on the tube with the threaded end of the flare nut facing the end of the tubing to be flared.
4. Insert the tubing in the flaring block as shown in Figure 10. The tubing should extend no more than 1/3 of the depth of the flare block flare. If too much tubing extends above the block then the flare will be too large and

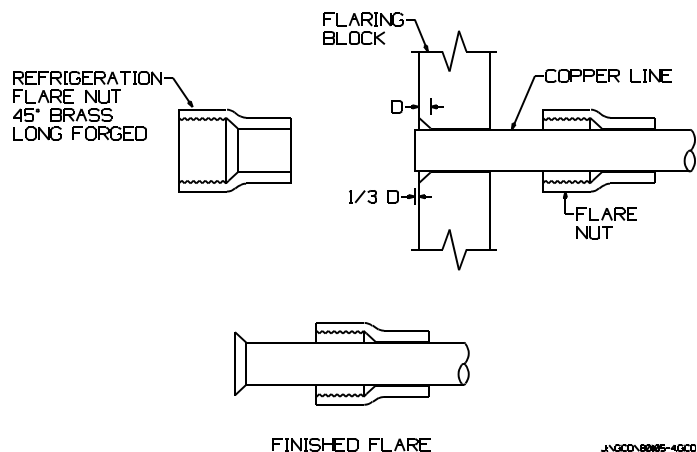

Figure 10 Flaring Copper Tubing

the flared tube will not fit into the flare nut. If not enough tubing extends above the block then the flare will be too small and will be squeezed out of the flare upon tightening causing the connection to leak refrigerant.

5. To form the flare place a drop of refrigerant oil (no other type of oil is acceptable) on the end of the flaring tool spinner. Turn the spinner into the tube three quarters of a turn then back one quarter. Continue this until the spinner will no longer turn.
6. Remove the flaring block and pull the flare nut up and over the flared end of the copper tubing. Verify that the flare fills the interior flared portion of the flare nut.

E. Thermostats

1. AQS1 and AQS3 Series Thermostat / Switch Assemblies

The thermostat switch assembly is the central distribution point for the split system electrical power.

The control panel should be mounted over a suitably sized hole (see templates in the back of the manual) using four screws. The plastic cover for the rear of the control must be installed to prevent someone from accidentally touching the exposed electrical connections.

The wires extending from the back of the control panel end in a terminal strip which should be securely mounted. After all of the wiring is completed, the covers that were supplied with the control panel (one for the terminal strip and one for the back of the control) must be installed.

The copper temperature sensing bulb must be mounted in the return air flow to the fan coil. There are two plastic clips on the face of the fan coil that are specifically for mounting this

sensor. The sensing bulb must never be mounted with the bulb in direct contact with the fan coil. The bulb should not be mounted on a surface that would be warmer than the surrounding air (i.e. an engine room bulkhead or the hull side).

Fig. 11
AQS3
Series
Thermostat

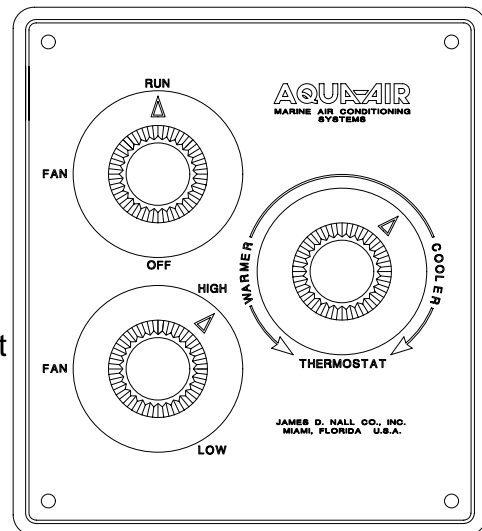

2. *Tempwise 2001 TW2D Series Digital Thermostat*

The display panel should be mounted over a suitably sized hole (see templates in the back of the manual) using the double-sided tape provided.

The display head should not be mounted in an area that is exposed to direct sunlight or other heat sources as this will affect the air temperature sensor that is mounted in the display head.

The control module box should be mounted close to the fan coil so that the fan motor wire can easily be attached to the control module terminal block.

All wiring connections for the unit will be made on the terminal strip inside the control module box. Connect the fan coil motor wire to the control module box. Replace the control module cover after wiring.

Install the display cable phone wire connecting the display panel to the control module box.

Figure 12
TW2D Series
Display Head

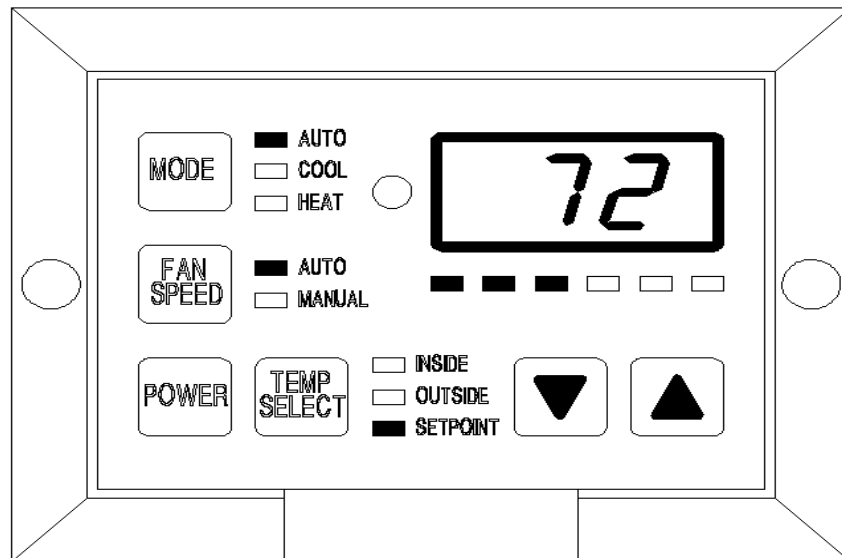

3. *Tempwise 2001 TW2-01B or W Digital Thermostat Display Head with 'T' Series Condensing Units*

The control module for the digital thermostat is already factory mounted on the condensing unit.

The display panel should be mounted over a suitably sized hole (see templates in the back of the manual) using the double-sided tape provided.

The display head should not be mounted in an area that is exposed to direct sunlight or other heat sources as this will affect the air temperature sensor that is mounted in the display head.

Install the display cable phone wire connecting the display panel to the control module box located on the condensing unit.

Connect the fan coil motor wire to the control module box.

Recommended Wire and Circuit Breaker Sizes			
Unit Capacity BTU/H	Voltage	Wire Size AWG	Circuit Breaker Rating, Amps
5,000	115	14	10
7,000	115	14	15
10,000	115	12	20
12,000	115	12	20
16,000	115	10	30
7,000	230	14	10
10,000	230	12	15
12,000	230	12	15
16,000	230	12	20
20,000	230	12	20
24,000	230	12	20
30,000	230	10	30
36,000	230	10	30

Table 4

F. Seawater Pumps

The seawater pumps supplied by Aqua-Air® are all centrifugal, non-self priming pumps. They must be installed in the following manner:

1. The pump must be mounted securely at a point in the hull that is beneath the waterline of the boat under ALL conditions (at rest, under way or in a heavy sea). The position of the pump should be as close as possible to the centerline of the boat, no further forward than the front of the engine compartment and no further aft than the propeller stuffing boxes or aft engine compartment bulkhead. Mount the pump as low as possible in the hull. The pump should always be mounted in a horizontal position and never on its head or end. See Figure 5 below.

Figure 13

Seawater Pumps can be mounted in any horizontal position (within the range shown at right) and will still be self-purging.

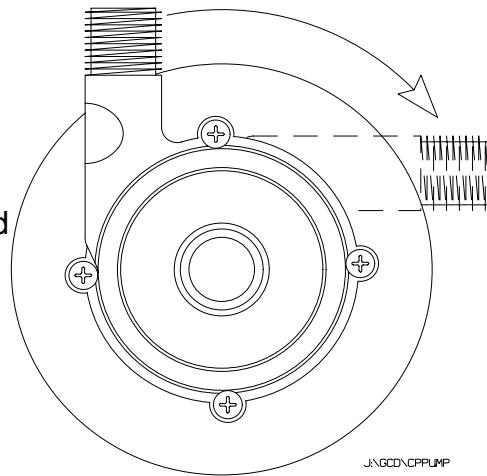

2. To make the system self purging there must be a steady uphill run from the seawater inlet to the seawater strainer through the pump up to the condensing unit and then overboard (See Figure 14). This will allow any air that enters the seawater inlet to bleed off naturally through the seawater system.
3. Connect the pump wire to the condensing unit according to the applicable wiring diagram. The ground wire must be connected to the green ground lug.
4. On a system with more than one condensing unit connected to a single seawater pump the pump will be wired to the pump relay.
5. The seawater pumps CANNOT be run without a supply of water. If they are run dry internal damage will be caused voiding the pumps warranty.

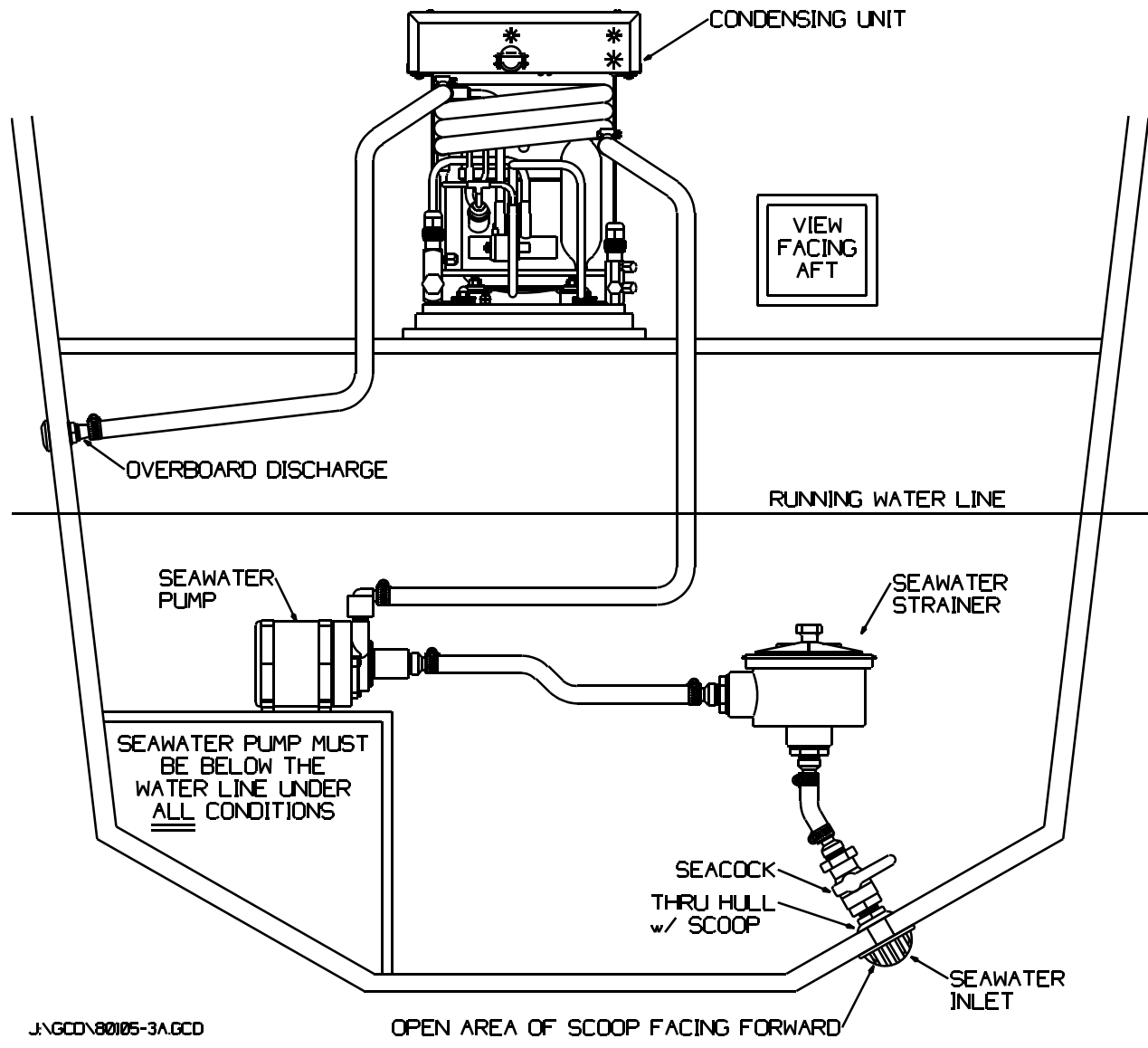

J:\GCD\80105-3A.GCD

Figure 14 Typical Seawater Circuit

IV. Before Starting the System for the First Time

Below is a preliminary check list that should be verified before operating the system for the first time:

1. The fan coil is securely fastened in place.
2. The supply and return air grilles meet the minimum area requirements
3. There is a return air filter installed
4. The insulated duct is installed with a minimum of bends and without any kinks that would restrict the air flow.
5. All electrical covers (either on the thermostat or the condensing unit) are in place.
6. The thermostat temperature sensing bulb or sensor is in the return air flow but not touching the evaporator coil or housing.
7. The fan coil drain pan is draining properly. This can be checked by pouring water into the pan and verifying that it drains.
8. All wire harnesses or phone wires connecting the thermostat or display head are properly connected to the unit or the control module box.
9. The flare joints on the condensing unit and fan coil have been made according to the Aqua-Air[®] instructions
10. The pump and/or pump relay wires are correctly connected to the condensing unit.
11. The electrical power line from the ship's distribution panel is properly connected to the thermostat (AQS1 or AQS3 or TW2) or to the condensing unit according to the applicable wiring schematic for the equipment used. Make sure that a time delay type circuit breaker is used.
12. The copper refrigerant lines connecting the condensing unit to the fan coil unit are properly insulated and sealed. The line set should be fastened every 18" (.5m) throughout the vessel.
13. The condensing unit is securely fastened down and is accessible for service.
14. The flare nuts on the fan coil are insulated. This should be done after checking the system for leaks.
15. The seawater system is piped in the recommended way so as to be self purging of air.
16. The pump is mounted well below the waterline of the boat.
17. There should be a properly sized seawater strainer between the seawater inlet and the pump.
18. The seawater inlet is a scoop type with the open portion of the scoop facing forward.
19. There should be a separate overboard fitting for each condensing unit. It should be mounted no more than 2" above the waterline.
20. The seawater inlet should be no further than 6" from the centerline of the boat.

V. System Leak Checking & Charging

The following instructions should be used when initially leak checking and charging the Aqua-Air® Direct Expansion Split System with Refrigerant 22.

| | | WARNING | | |

Title VI of the EPA Clean Air Act, Section 608.c.1 states the following:

“Effective July 1, 1992, it shall be unlawful for any person, in the course of maintaining, servicing, repairing, or disposing of an appliance or industrial process refrigeration, to knowingly vent or otherwise knowingly release or dispose of any Class I or Class II substance used as a refrigerant in such appliance (or industrial process refrigeration) in a manner which permits such substance to enter the environment. De minimis releases associated with good faith attempts to recapture and recycle or safely dispose of any such substance shall not be subject to the prohibition set forth in the preceding sentence.”

Personnel handling Refrigerant 22 (which is classified as a Class II substance) must be EPA certified and must use EPA approved refrigerant recovery equipment.

In the past it was an accepted practice to use the refrigerant contained inside the condensing unit to purge the air from the refrigerant line sets. This is no longer legal and is not recommended by Aqua-Air®. The only acceptable means of purging the refrigerant line sets and charging the unit with refrigerant are outlined below. Any deviation from these procedures can result in Federal prosecution for the illegal venting of refrigerants.

| | | WARNING | | |

The condensing unit is shipped with an initial refrigerant charge sufficient for approximately a 30' (10m) line set. The fan coils are shipped with a dry nitrogen charge. The refrigerant line sets that you have installed currently have air in them.

The first procedure you will perform is to evacuate the line set and fan coil of all air and its inherent moisture content. At the same time you will be checking the integrity of the refrigerant flare connections that you have made at the condensing unit and fan coil(s).

The second procedure is the actual release of the refrigerant that is contained in the condensing unit into the system.

To perform these procedures you will need the following tools:

1. Four valve refrigeration charging manifold with check valve type self sealing refrigerant hoses.
2. Vacuum pump capable of evacuation down to at least 25 microns.
3. Ratchet wrench with a 1/4" square opening
4. 9/16" box wrench
5. Adjustable wrench
6. Thermometer
7. Can of Refrigerant 22 (usually a standard 30 or 50 pound drum)

A. Leak Checking the System

1. Verify that the flare connections at the condensing unit base valves, at the fan coil(s) and any refrigerant tee's that are in the refrigerant line sets are all tight.
2. Using the 9/16" box wrench remove the lower charging port brass cap on the liquid line base valve.
3. Attach the suction gauge hose (usually the blue hose) from the refrigeration gauge manifold set to the charging port.
2. Attach the vacuum hose from the refrigeration gauge manifold set to the vacuum pump.
3. Attach the refrigerant hose from the refrigeration gauge manifold set to the can of refrigerant. The valve on the refrigerant can should remain in the OFF (counter clockwise) position.
4. Verify that all hose connections are tight
5. Turn the vacuum pump on and fully open both the vacuum valve and the refrigerant valve on the refrigeration gauge manifold set.
6. Allow the vacuum pump to run until the suction gauge indicates the system has pulled down to at least 28 in. Hg.
7. Close both the vacuum valve and the refrigerant valve on the refrigeration gauge manifold set. Note the exact reading on the suction gauge.
8. Allow the system to sit for 15 minutes and then verify that the suction gauge pressure has not increased which would indicate a leak. If the gauge pressure has increased check all of the flare connections again and return to step 6 of this procedure. Once the system will hold the vacuum for the 15 minutes proceed to the next step.
9. Continue to evacuate the system down to at least 29.5 in Hg. and then close the vacuum valve on the refrigeration gauge manifold set. Allow the system to sit for an hour and then verify that the pressure has not risen. If it has risen then there is a leak. Check the flare fittings again and tighten or re-flare as necessary and return to step 6. If the pressure has not risen continue on to the next step.
10. With the refrigerant tank upright (so that you are getting refrigerant gas and not liquid) open the tank valve which will allow refrigerant to enter the line set and the fan coil. Keep the valve open until the suction gauge indicates a pressure of 0 psig then close the refrigerant tank valve.
11. Remove the suction gauge hose from the charging port and replace the brass cap on the port. Tighten the cap with the 9/16" box wrench.
12. Remove the valve stem caps from the top of both base valves with

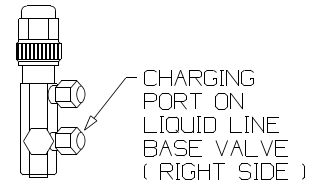

- an adjustable wrench.
13. Using the ratchet wrench fully backseat (turn counterclockwise) the valve stems on both base valves. This allows the refrigerant that was stored in the condensing unit to enter the refrigerant line set and fan coil.
 14. Replace and tighten the valve stem covers with the adjustable wrench.

The system is now ready to be run to verify that the refrigerant charge is correct.

B. Charging the System

1. Remove the charging port cap on the condensing unit suction base valve and the upper charging port on the liquid line base valve with the 9/16" box wrench.
2. Attach the suction gauge hose (usually the blue hose) from the refrigeration gauge manifold set to the suction base valve charging port.
3. Attach the discharge gauge hose (usually the red hose) from the refrigeration gauge manifold set to the liquid line base valve upper charging port.
4. Verify that all of the valves on the refrigeration gauge manifold set are in the closed (clockwise) position.
5. Attach the refrigerant hose from the refrigeration gauge manifold set to the refrigerant tank (this may already be done if continuing from the leak check procedure).
6. Remove the valve stem caps from the top of both base valves with an adjustable wrench.
7. Frontseat (turn clockwise) both valve stems one full turn. This will allow pressure to enter the refrigeration gauge manifold set.
8. Using the thermometer measure the following:
 1. Room temperature that the fan coil is serving
 2. Seawater temperature
9. Using the charging tables provided verify that the refrigerant pressures fall within $\pm 10\%$ of the values on the chart.
10. If the suction refrigerant pressure is low add refrigerant to the system. If they are within the normal parameters then go to step 14.
11. To add refrigerant to the system first open the valve on the refrigerant tank and verify that the tank is in the upright position. This will insure that only refrigerant gas (and not liquid) is introduced into the system. If you need to remove refrigerant from the system (an overcharge condition) see the separate section titled " Refrigerant Recovery from the System".

12. Slowly open the refrigerant valve on the refrigeration gauge manifold set. This will begin to allow refrigerant into the system. Continue to do this at short intervals until the system pressures are within parameters.
13. Once the system is fully charged close the valve on the refrigerant tank and verify that the refrigerant valve on the refrigeration gauge manifold set is closed.
14. Using the ratchet wrench fully backseat (turn counterclockwise) the valve stems on both base valves.
15. Replace the valve stem covers on both base valves and tighten the caps with the adjustable wrench.
16. Remove the charging hoses from both base valves and replace the brass caps on the charging ports. Tighten the caps with the 9/16" box wrench.

C. Recovering Refrigerant from the System

If a situation occurs where the system refrigerant pressures are higher than what is shown on the refrigerant charging charts, refrigerant will have to be removed from the system. This refrigerant CANNOT be directly vented to the atmosphere (see the warning at the beginning of this section). It must be "recovered" using an EPA approved recovery unit and DOT approved refillable recovery cylinder. As there are numerous types of recovery units available we will not give you an exact recovery procedure. The best thing to do is to follow the procedures set forth by the recovery unit manufacturer for vapor (gas) recovery.

VI. System Operation

B. Systems Using the AQS1 or AQS3 Series Thermostat

1. Verify that the OFF-FAN-RUN switch is in the OFF position.
2. Turn the unit circuit breaker ON.
3. Turn the thermostat to the desired setting (either cooling or heating).
4. Set the fan speed control to HIGH
5. Verify that the seawater inlet valve is ON and the seawater strainer is clean.
6. Turn the OFF-FAN-RUN to the FAN position. This will start the fan motor and seawater pump. Look over the side of the boat and verify that seawater is coming out of the seawater overboard. If it does not after 15 seconds stop the put the OFF-FAN-RUN in the OFF position and find out why there is no seawater flow.
7. Turn the OFF-FAN-RUN switch to the RUN position. The compressor will now start and begin either cooling or heating.

8. To set the thermostat to maintain a certain temperature, turn the thermostat toward the center position until a single click is heard. The thermostat is now set to maintain the current room temperature. To change the room temperature by a few degrees rotate the knob about 1/8" at a time and then wait 15 minutes for the room temperature to adjust.
9. Set the fan speed control to the desired setting. On the heating cycle run the fan on low speed for about 15 minutes and then increase to medium speed. This will allow the unit to build up temperature. In the cooling cycle the fan can be run at any speed. In either mode unit capacity decreases as fan speed decreases.
10. It is not advisable to turn the system on and off rapidly. It is usually a good idea after turning the system off to allow at least five minutes to pass before starting the unit again.
11. To turn the system OFF turn the OFF-FAN-RUN switch to the OFF position.

B. Systems Using the Tempwise 2001 Digital Thermostat

1. Verify that the seawater inlet valve is ON and the seawater strainer is clean.
2. Turn the unit circuit breaker ON.
3. Press the POWER button on the face of the Tempwise 2001 one time. The LED display will now indicate the current room temperature.
4. Press and release the MODE button until the desired operating mode is reached (AUTOMATIC operation, COOLING only, HEATING only or MOISTURE CONTROL mode).
5. View the current thermostat set point by momentarily pressing either the < (increase temperature) or > (decrease temperature) key. To change the set point continue to press the < or > key until the desired set point is reached.
6. Fan speed operation initially is in the AUTO(matic) mode. This means that the fan speed will be automatically selected based upon how close the room temperature is to set point. The fan speed will be at its lowest setting at set point. To change the fan speed setting press the FAN key until the desired fan speed is achieved. Continuing to hold the FAN key will scroll through the six fan speeds and then return to the AUTOMATIC mode.
7. For further operating information on the TW2 thermostat please refer to the thermostat operation manual.

C. Reverse Cycle Systems

Most Aqua-Air® units are reverse cycle heat pump units. This type of system derives its heat from the seawater that is pumped through the seawater condenser. When the water temperature reaches 40°F there is an approximate 50% loss in heating capacity. As the water temperature reaches 35°F there will be little or no heating available. This should be kept in mind when considering the practicality of a reverse cycle system for the area that you will be operating in during the winter months.

VII Maintenance

A. Fan Coils

1. The fan motors should be lubricated on a yearly basis with SAE 20 oil
2. The drain pans should be checked for proper drainage by pouring a quart of water into the pan. The water should drain within thirty seconds.
3. Clean all return air filters at the beginning of the boating season and then regularly on a monthly (or sooner as use dictates) basis.

B. Seawater System

1. The seawater pump requires no maintenance
2. The seawater strainer should be cleaned at the beginning of the boating season and then regularly on a monthly (or sooner as use dictates) basis.

VIII Winterizing

Condensing Unit.

Turn the seawater inlet off. Remove the seawater hose from the seawater pump outlet. This will allow the water to drain from the unit as long as the system is piped correctly.

Seawater Pump

With the seawater inlet off loosen the screws on the front of the pump. This will allow any water in the pump head to drain.

Seawater Strainer

Drain and clean the strainer

Seawater Inlet

Remove the hose at the inlet valve and remove as much water from the valve as possible.

Seawater Outlet

Remove the hose at the seawater outlet. Install a cap over the fitting to prevent any water from entering the fitting.

| | | WARNING | | |

Aqua-Air Manufacturing (a division of the James D. Nall Company, Inc.) hereafter referred to as the "Manufacturer" makes the following warnings in regard to the use of its products. Even though these warnings are comprehensive in nature, there are certain dangers that might arise which, at this time, are unforeseeable. A thorough understanding of the dangers outlined below will help as a guide for spotting other potentially dangerous situations. This understanding is very important in assuring your safety.

Electricity

Aqua-Air® products operate on voltages ranging from 24 to 480 volts of alternating current (A.C.) Power. Because of the danger involved with these voltages, all metal components (bases, cabinets, units) must be grounded in some manner to the ship's grounding system. Some of the relays, switches and thermostats used in the Aqua-Air® systems are not ignition protected. Because of this, the ventilation blower on a boat should be run for five minutes prior to and during the operation of any Aqua-Air® product or system. All electrical connections must be sealed or covered in such a way as to prevent contact by unauthorized personnel. Such contact could lead to permanent injury or death.

Electrolysis

Any electrical leakage of a component can cause electrolysis. This could lead to a deterioration of a thru-hull which could cause leakage of water into the boat which could result in sinking the boat. All Aqua-Air® products must be kept clean and dry. They should be periodically inspected for electrical leakage. If detected, the faulty component should either be repaired or replaced.

Refrigerant

All Aqua-Air® products utilize refrigerant 22 (monochlorodifluoromethane). This refrigerant is non-toxic and non-flammable. This refrigerant contains no oxygen and will therefore no support life. When burned this refrigerant deteriorates into potentially lethal gases. If a refrigerant leak is discovered, evacuate all personnel from the are and prohibit the use of any item using an open flame. Due to the high pressures involved in refrigeration systems, eye protection, gloves and long-sleeved clothes should be worn during servicing of a system. Extensive frost burns can occur to the eyes and skin if they come into contact with liquid refrigerant.

Ventilation

To either cool or heat air, Aqua-Air® systems move air through a heat exchanger by means of either a propeller fan or blower system. This process naturally causes a suction on one side of the unit and a pressurized area on the other. These heat exchangers or "cooling units" as they are referred to in our brochures must be installed so that this suction-pressure action does not (1) pressure an area to the extent of causing structural failure of the area which could cause injury and does not (2) cause a suction in an area where vapors from batteries, fuel or other operating equipment exist. If a cooling unit were installed in this way then these vapors could possibly be discharged into a living space where they could be hazardous. The best way to prevent the introduction of dangerous gases into a living space is to make sure all living spaces are carefully sealed from all other spaces. It is never advisable to completely seal an area without some sort of auxiliary ventilation in the event of lethal gas or fumes escaping from any source.

Condensate

All Aqua-Air® direct expansion cooling units and self contained units produce condensate when operated in the cooling mode. The self contained units and condensing units can produce condensate during operation in the heating mode. This water must be drained overboard. If allowed to drip on a wood, dry rot can form causing structural failure. If allowed to drip on electrical components, deterioration of the components can occur. When the cooling unit is in operation, a negative pressure is exerted on the condensate line. Always locate condensate outlets as far as possible from sources of fumes or dangerous gases. These fumes or gases could be drawn into the system due to this negative pressure resulting in a potentially hazardous situation.

| | | WARNING | | |

Never sleep in an enclosed area in a boat when any equipment, which functions as a direct result of the combustion of a volatile fuel, is in operation (such as engines, generators, oil-fired heaters, etc.). At any time their exhaust system could fail leading to a build-up of dangerous gases within the enclosed area.

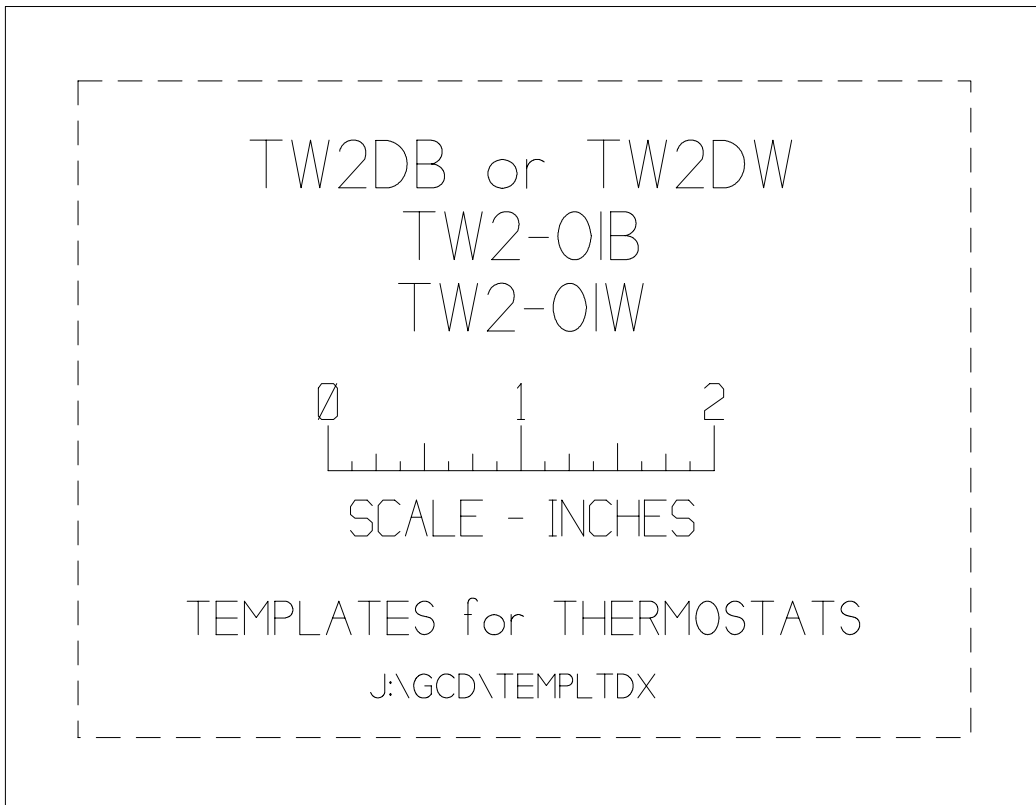
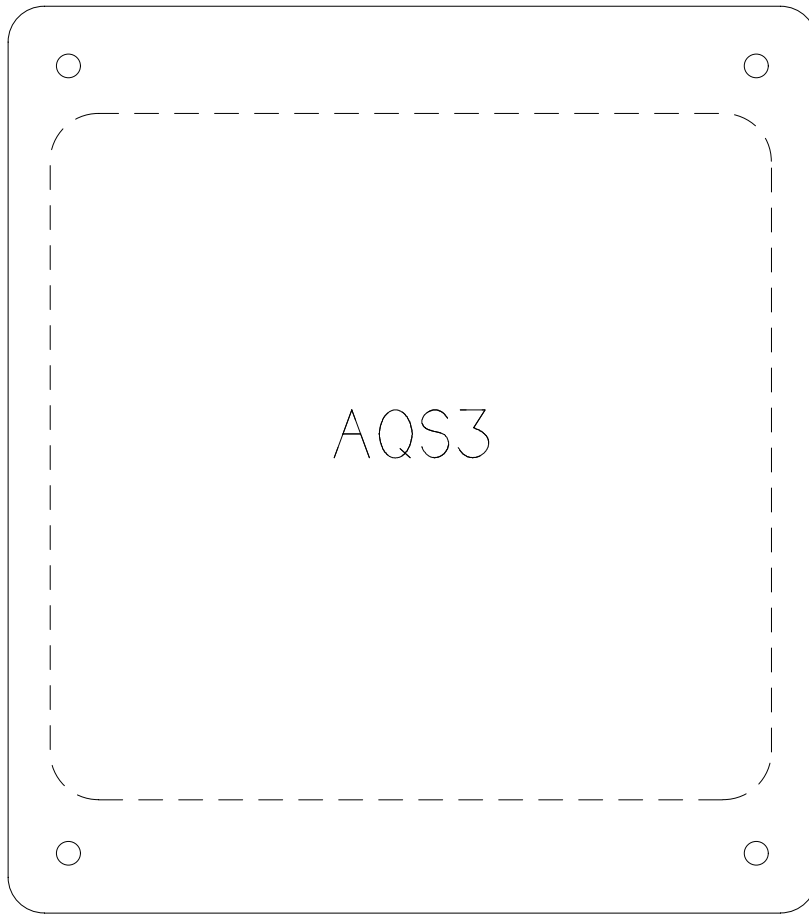

REFRIGERATION CHARGING CHARTS R-22 COOLING CYCLE

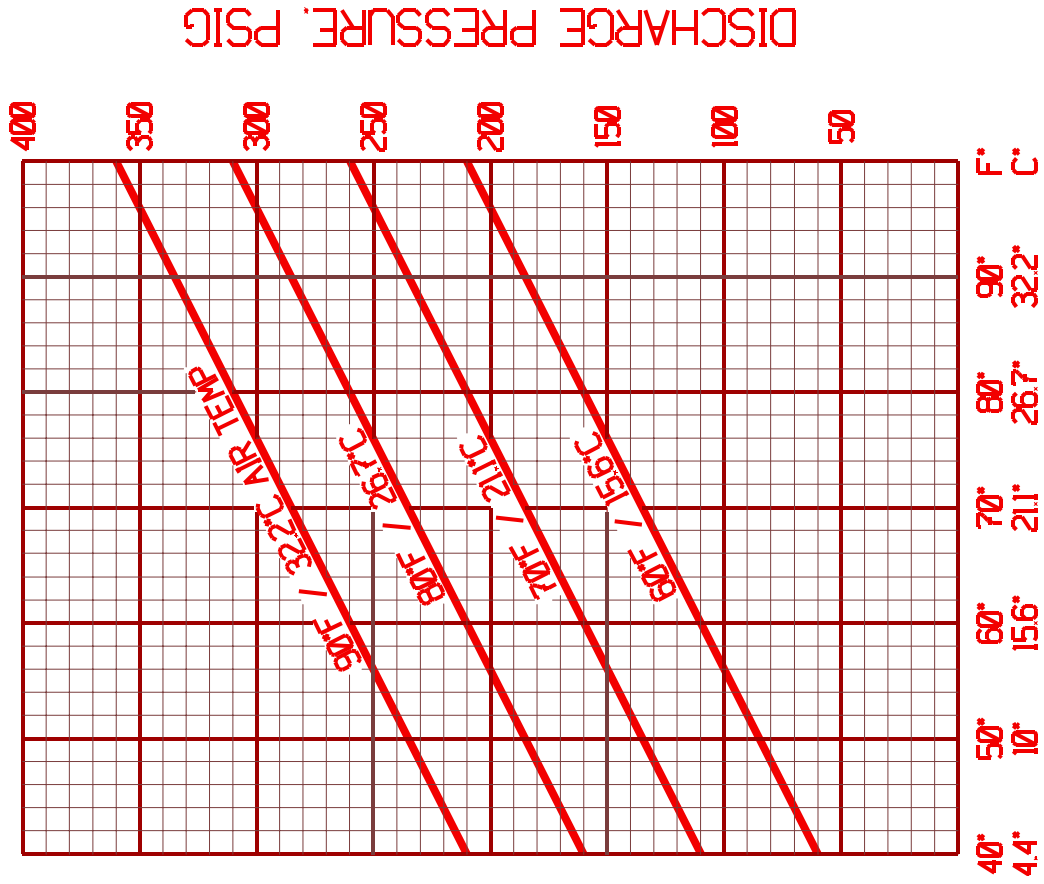

SEAWATER TEMPERATURE

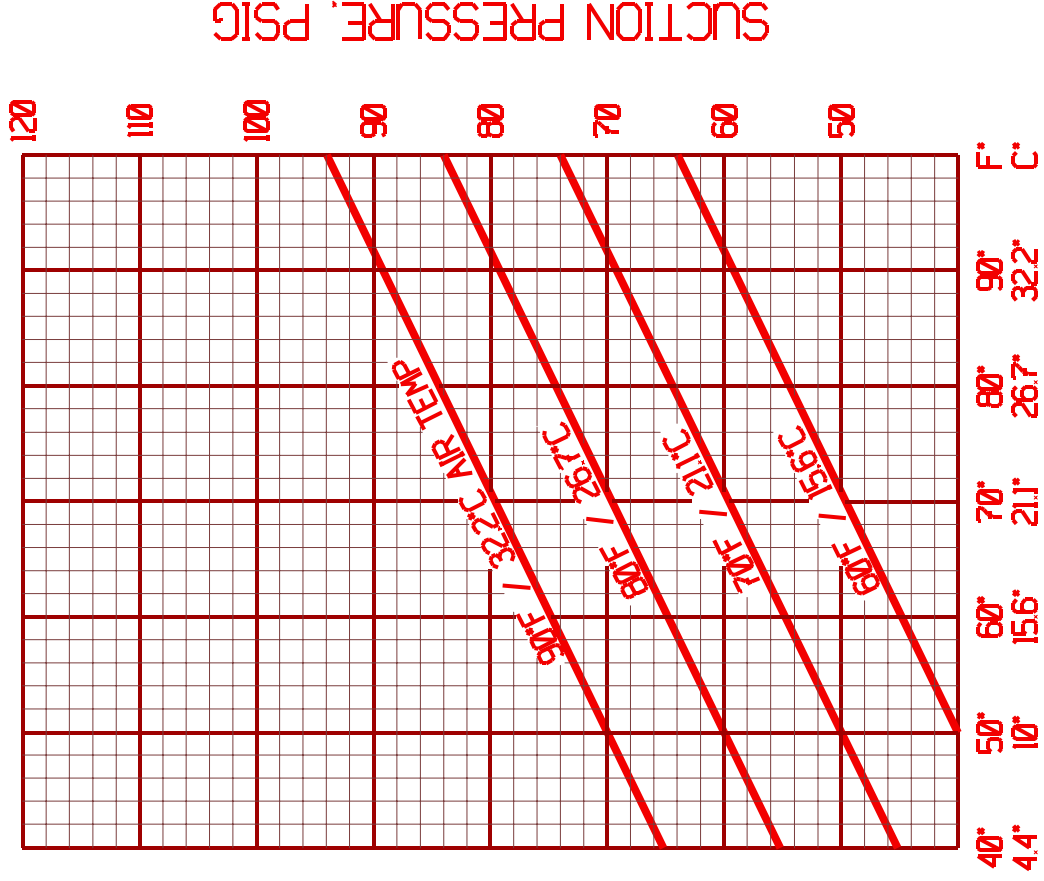

SEAWATER TEMPERATURE

JAGG01R220FRG000

Refrigerant Line Set Sizing

SYSTEMS USING ONE
CONDENSING UNIT &
ONE FAN COIL

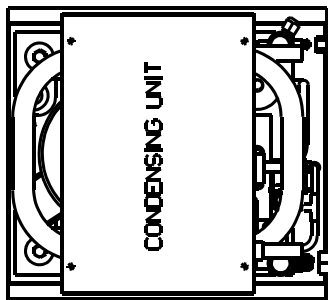

CONDENSING UNIT REFRIGERANT LINE SIZES

UNIT CAPACITY	SUCTION	LIQUID
5-12,000	3/8"	1/4"
16,000	1/2"	1/4"
20-24,000	1/2"	3/8"
30-48,000	3/4"	3/8"

FAN COIL REFRIGERANT LINE SIZES

UNIT CAPACITY	SUCTION	LIQUID
4-12,000	3/8"	1/4"
16,000	1/2"	1/4"
20-24,000	1/2"	3/8"
30-48,000	3/4"	3/8"

SYSTEMS USING ONE
CONDENSING UNIT &
TWO FAN COILS

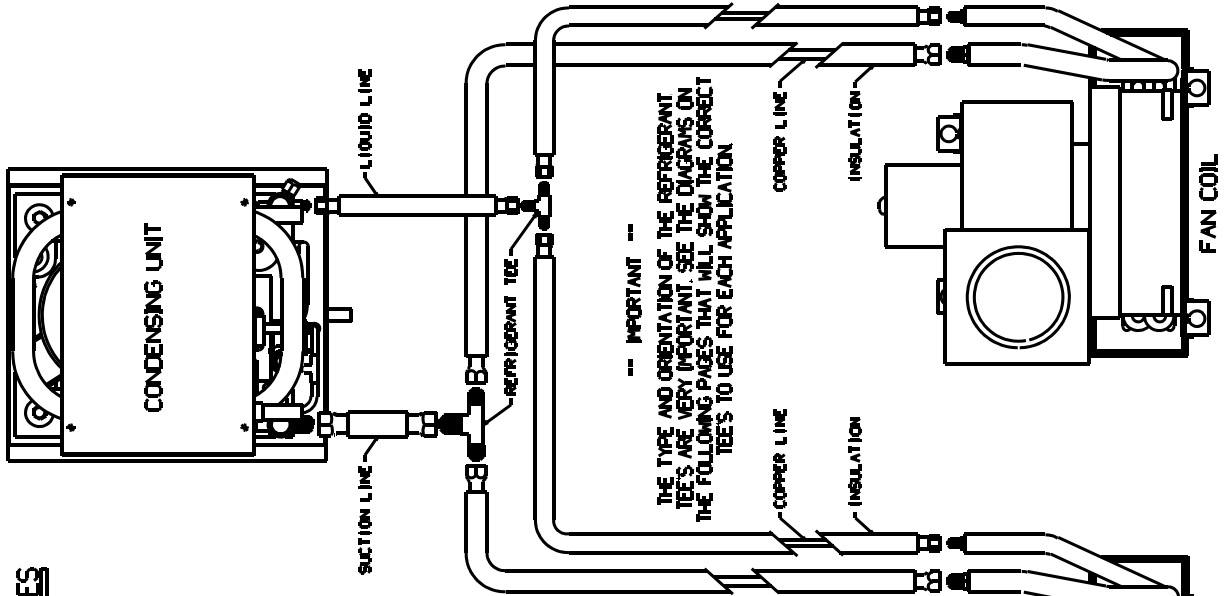

INSULATE FLARE NUT CONNECTION
AFTER LEAK CHECKING

J-950-996-7800

Tee Arrangements for Refrigeration Line Sets on Multiple Evaporator Systems

The purpose of this guide is to show some of the recommended line set and refrigeration tee arrangements for different size condensing unit and evaporator combinations.

The important thing to note on multiple evaporator systems is the orientation of the tee's when you have an evaporator capacity mismatch i.e. a 4,000 and 8,000 BTU/H fan coil connected to a 12,000 BTU/H condensing unit (shown below right).

See the drawing on the next page for Diagram A and B.

CONDENSING UNIT	FAN COIL		DIAGRAM	SUCTION LINE TEE			LIQUID LINE TEE				
	1	2		PART NUMBER	A	B	C	PART NUMBER	A	B	C
10,000	5,000	5,000	A	131210-06	3/8"	3/8"	3/8"	131209-04	1/4"	1/4"	1/4"
12,000	7,000	5,000	B	131210-06	3/8"	3/8"	3/8"	131209-04	1/4"	1/4"	1/4"
	8,000	4,000	B	131210-06	3/8"	3/8"	3/8"	131209-04	1/4"	1/4"	1/4"
16,000	8,000	8,000	A	131310-06	3/8"	3/8"	1/2"	131209-04	1/4"	1/4"	1/4"
	12,000	4,000	B	131310-08	1/2"	3/8"	3/8"	131209-04	1/4"	1/4"	1/4"
20,000	10,000	10,000	A	131310-06	3/8"	3/8"	1/2"	131301-04	1/4"	1/4"	3/8"
	12,000	8,000	B	131310-08	1/2"	3/8"	3/8"	131301-06	3/8"	1/4"	1/4"
	16,000	4,000	B	131311-13	1/2"	1/2"	3/8"	131301-06	3/8"	1/4"	1/4"
24,000	12,000	12,000	A	131310-06	3/8"	3/8"	1/2"	131301-04	1/4"	1/4"	3/8"
	16,000	8,000	B	131311-13	1/2"	1/2"	3/8"	131301-06	3/8"	1/4"	1/4"
	20,000	4,000	B	131311-13	1/2"	1/2"	3/8"	131310-04	3/8"	3/8"	1/4"
30,000	20,000	10,000	B	131312-01	3/4"	1/2"	3/8"	131310-04	3/8"	3/8"	1/4"
36,000	20,000	16,000	B	131311-12	3/4"	1/2"	1/2"	131310-04	3/8"	3/8"	1/4"
	24,000	12,000	B	131312-01	3/4"	1/2"	3/8"	131310-04	3/8"	3/8"	1/4"

SINGLE CONDENSING UNIT
WITH TWO EQUAL
CAPACITY FAN COILS

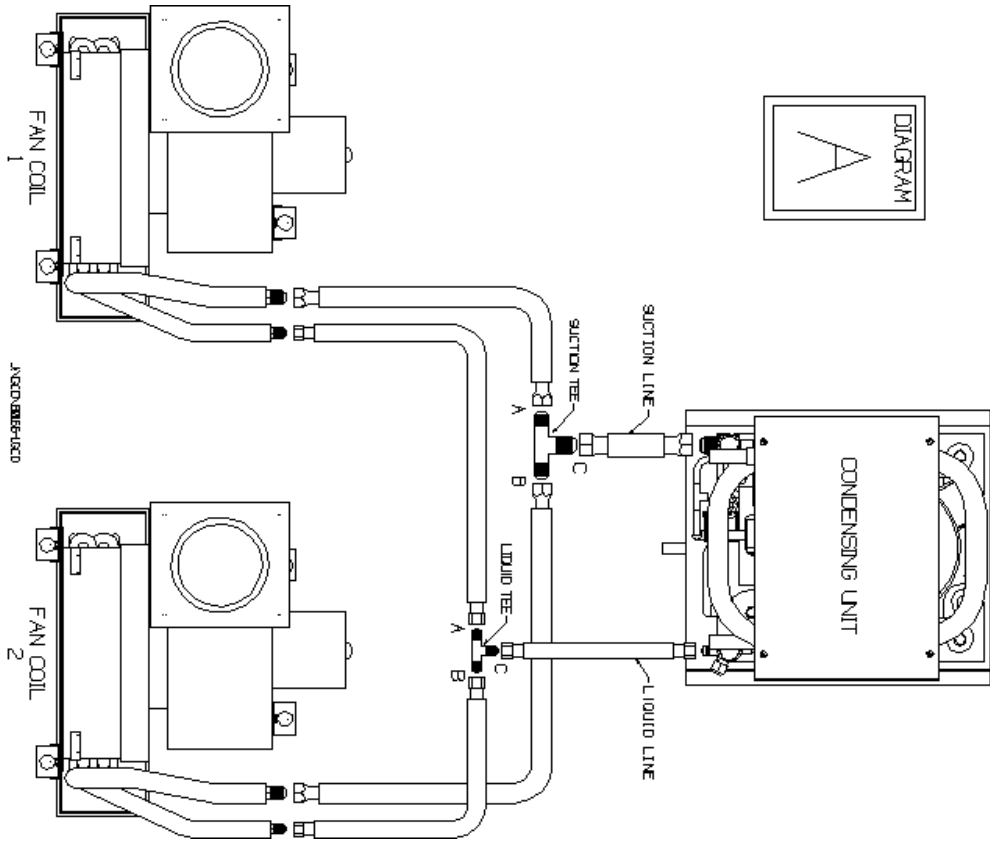

SINGLE CONDENSING UNIT
WITH TWO DIFFERENT
CAPACITY FAN COILS

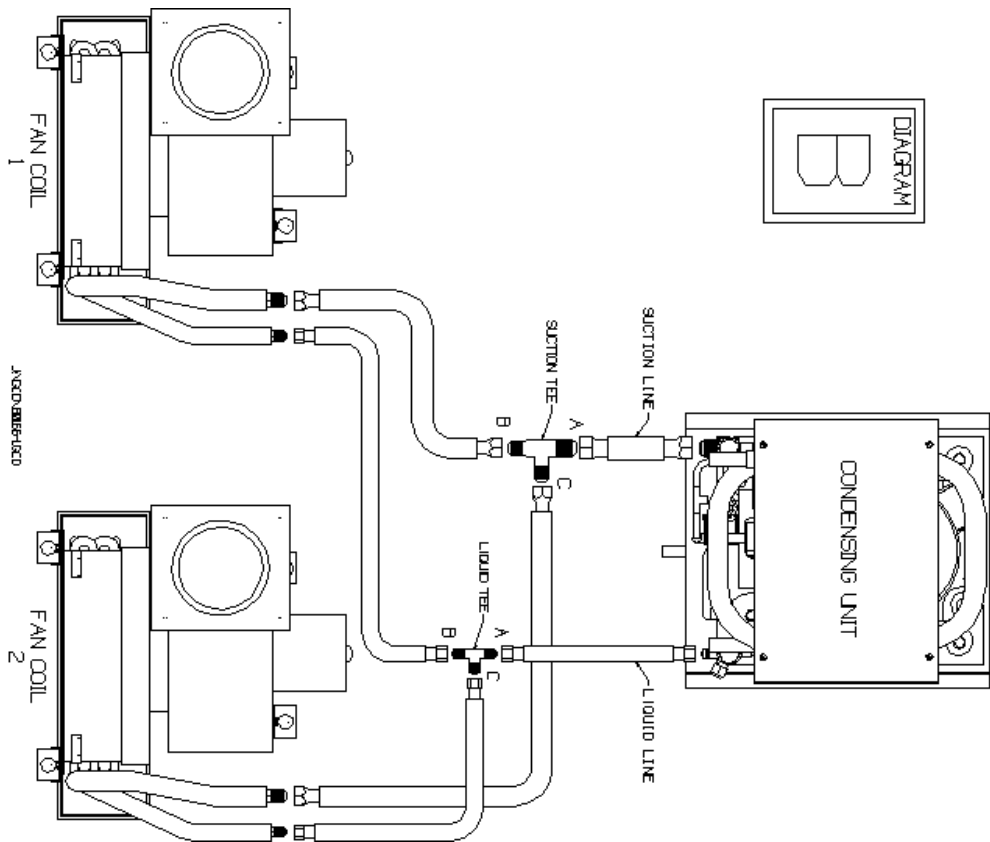

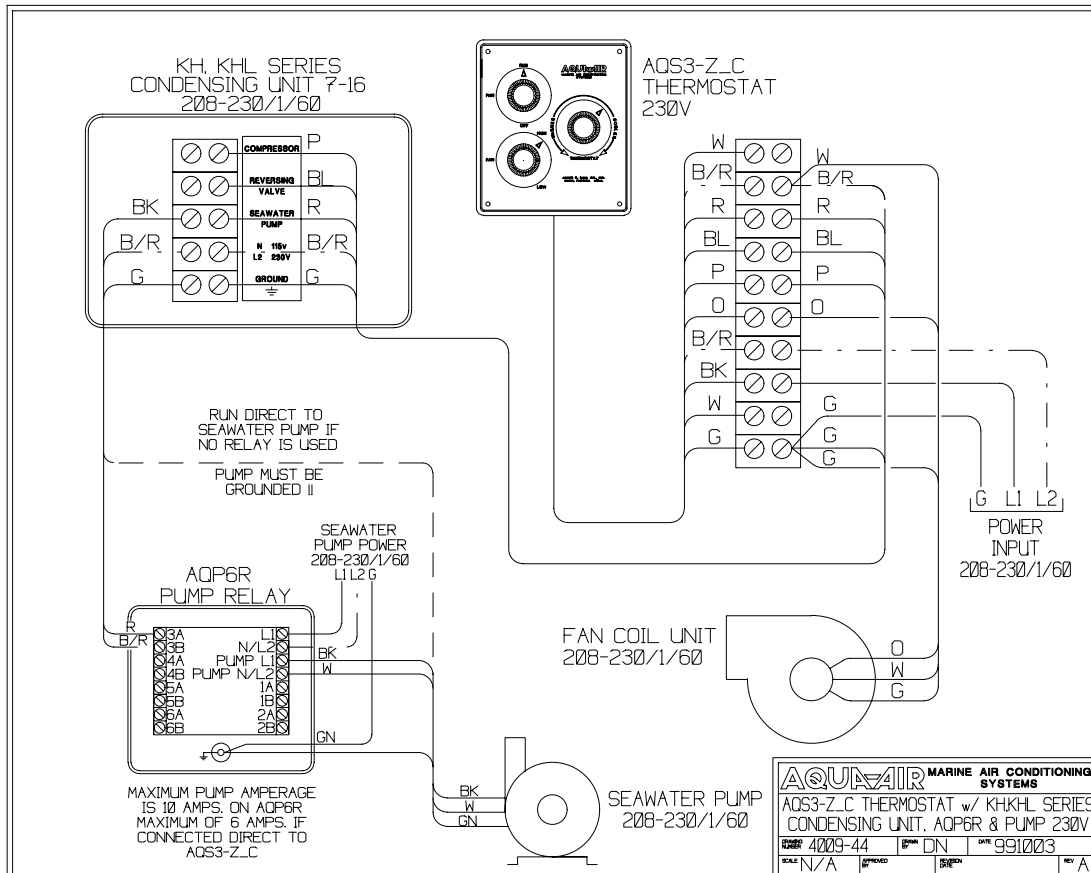
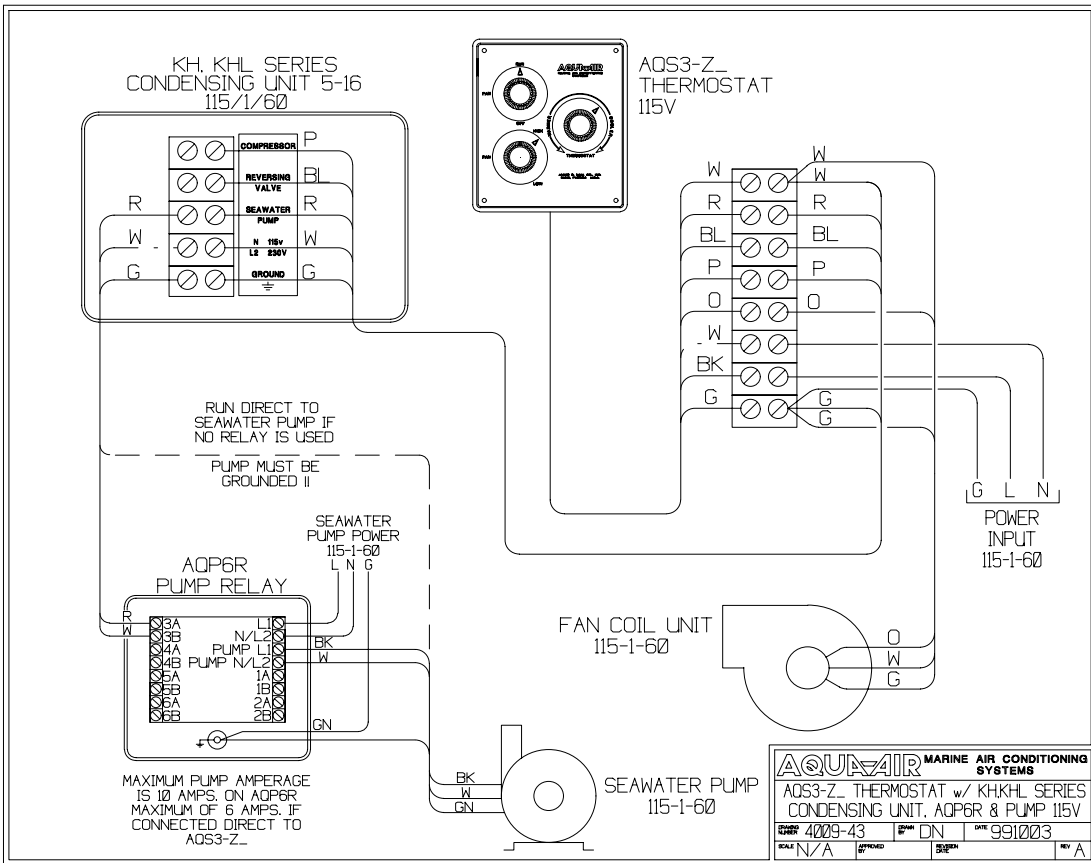

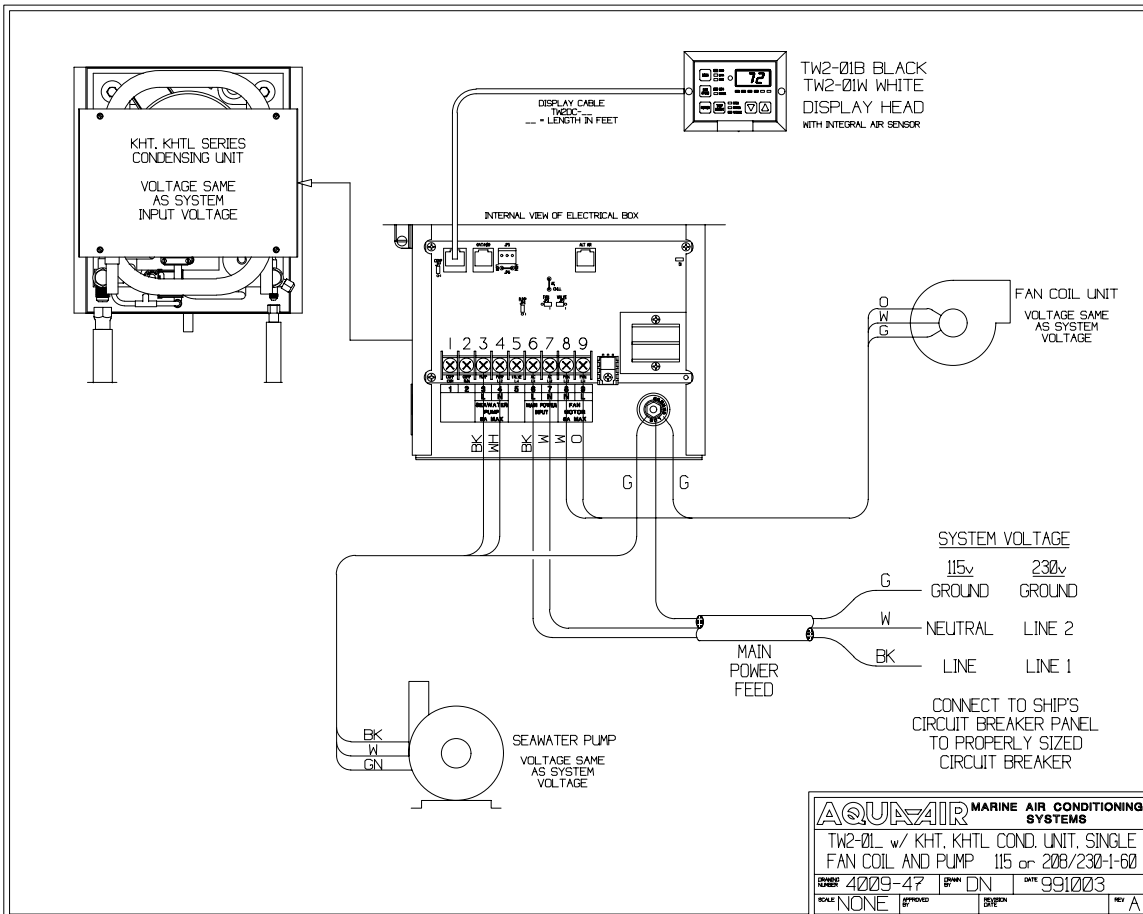
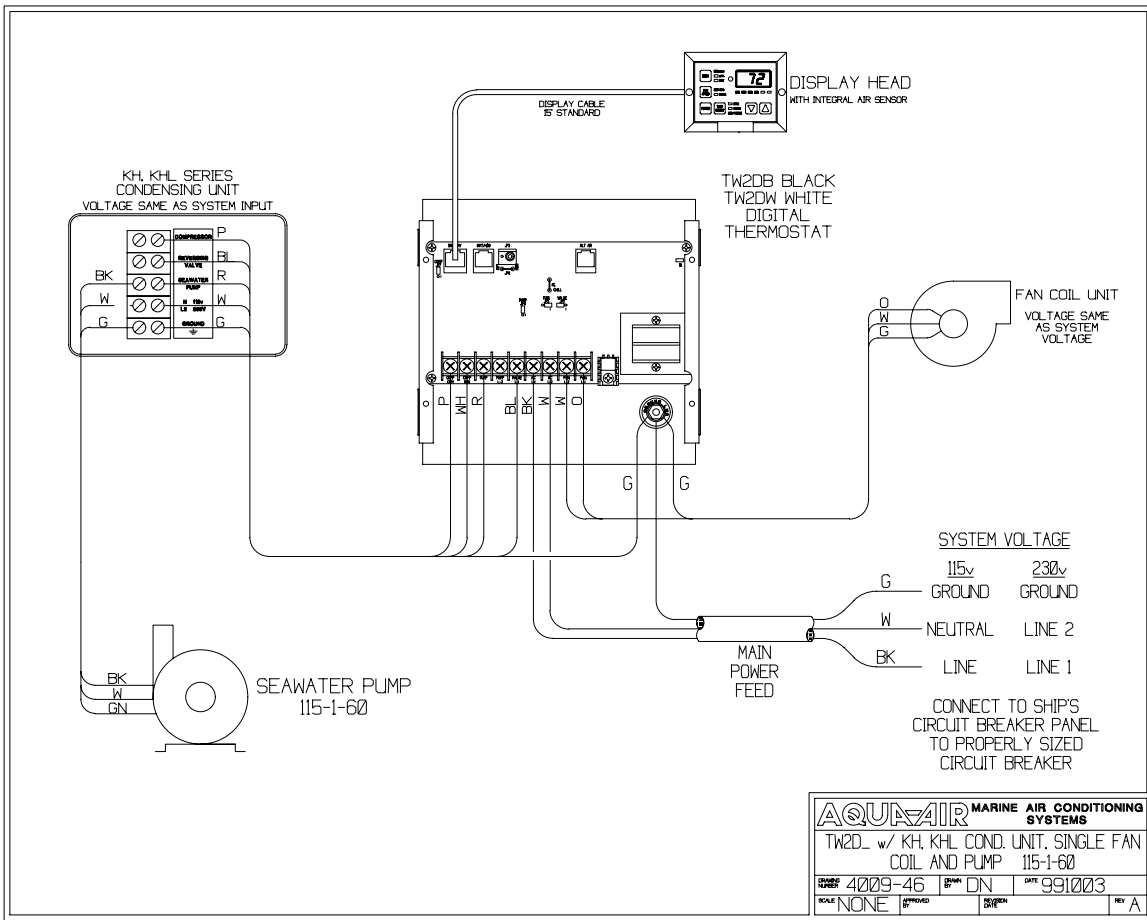

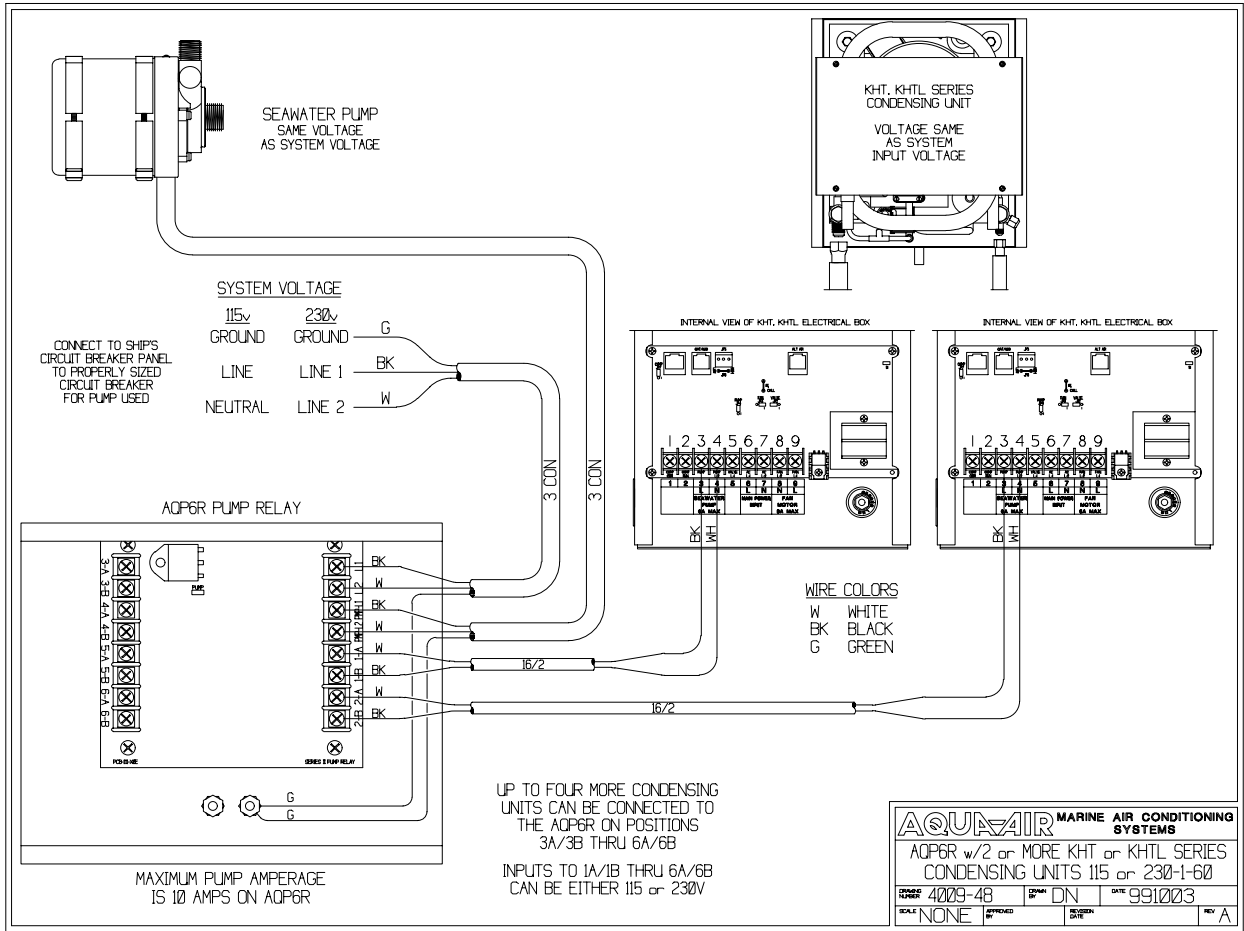

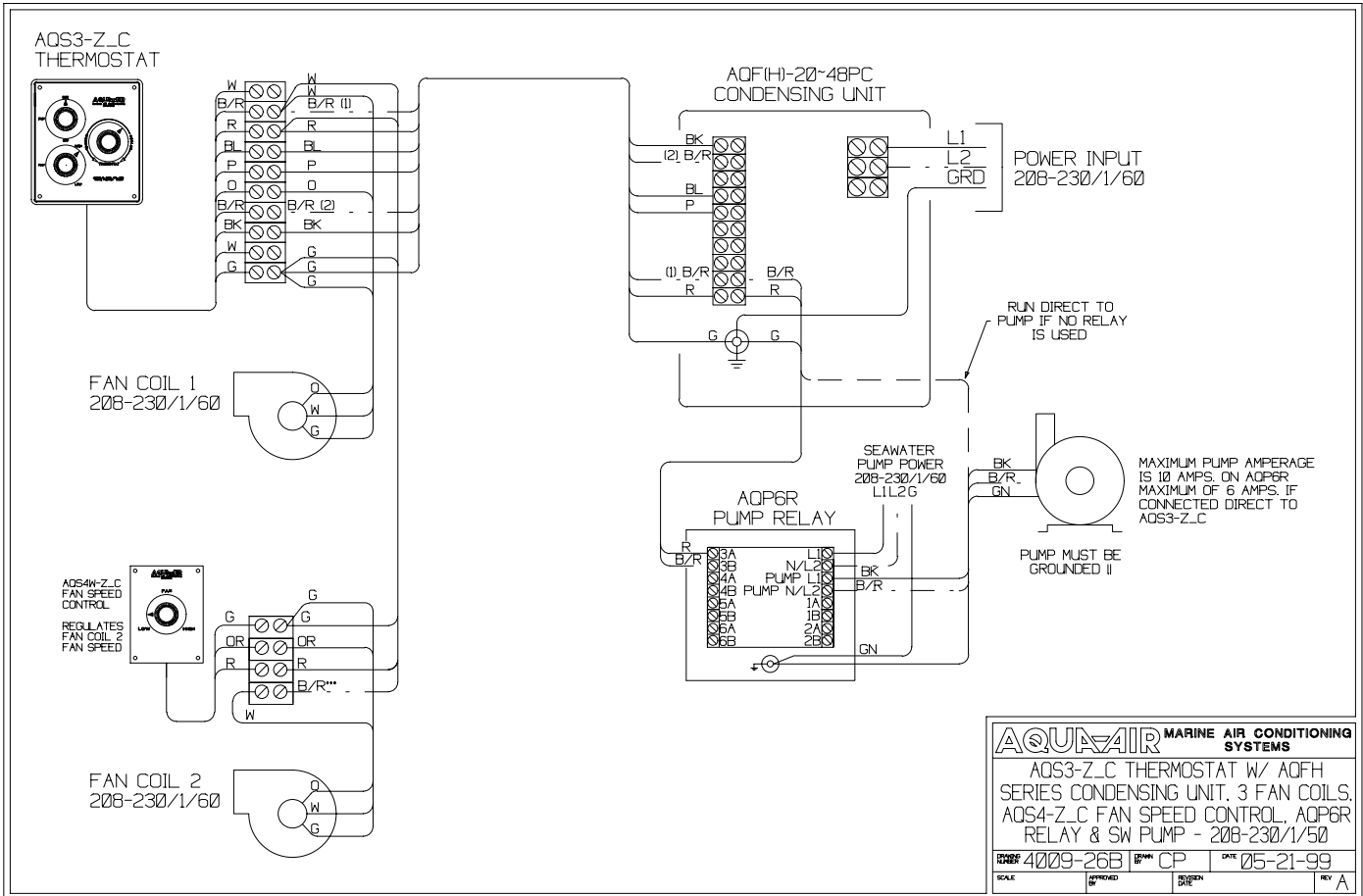
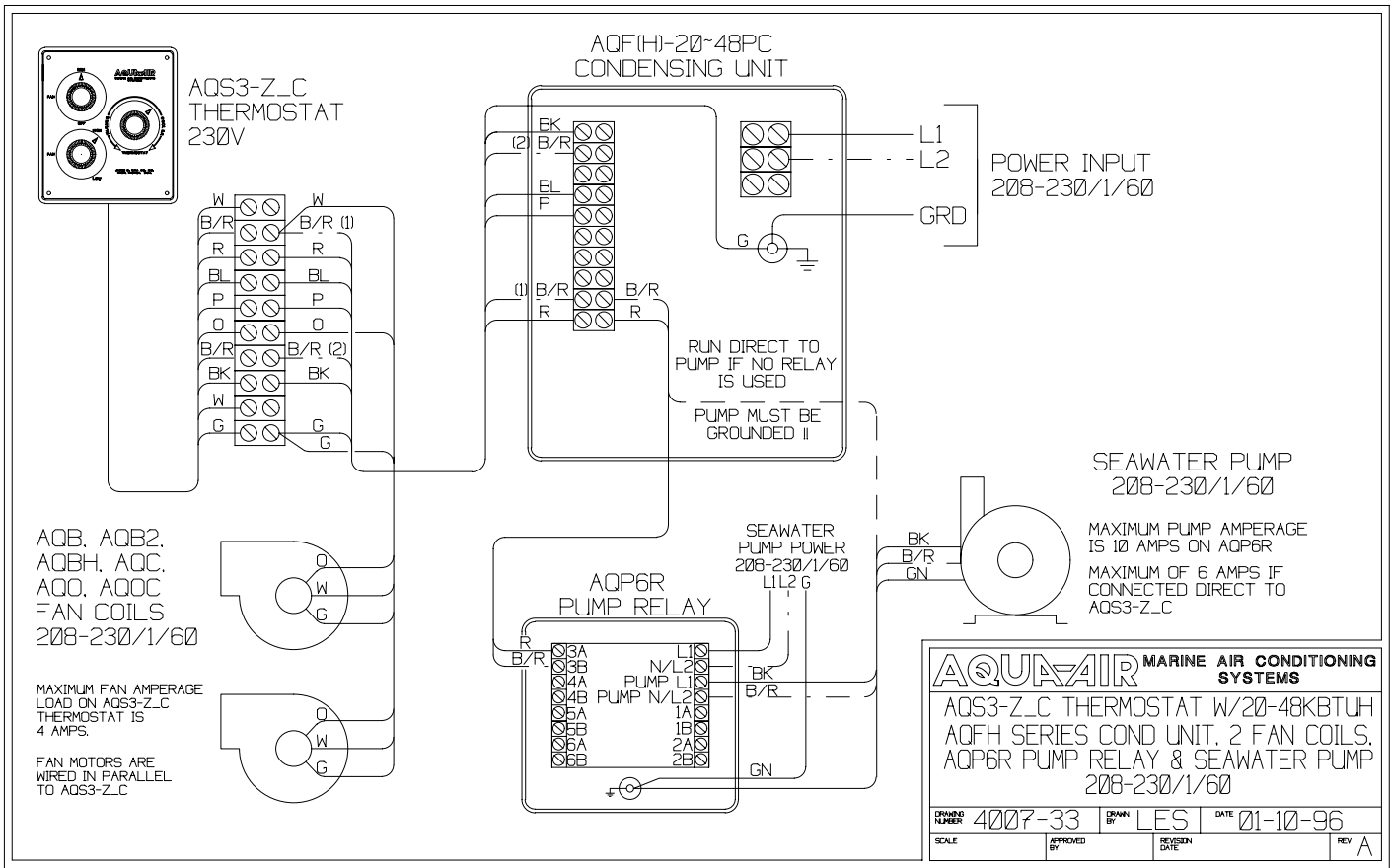

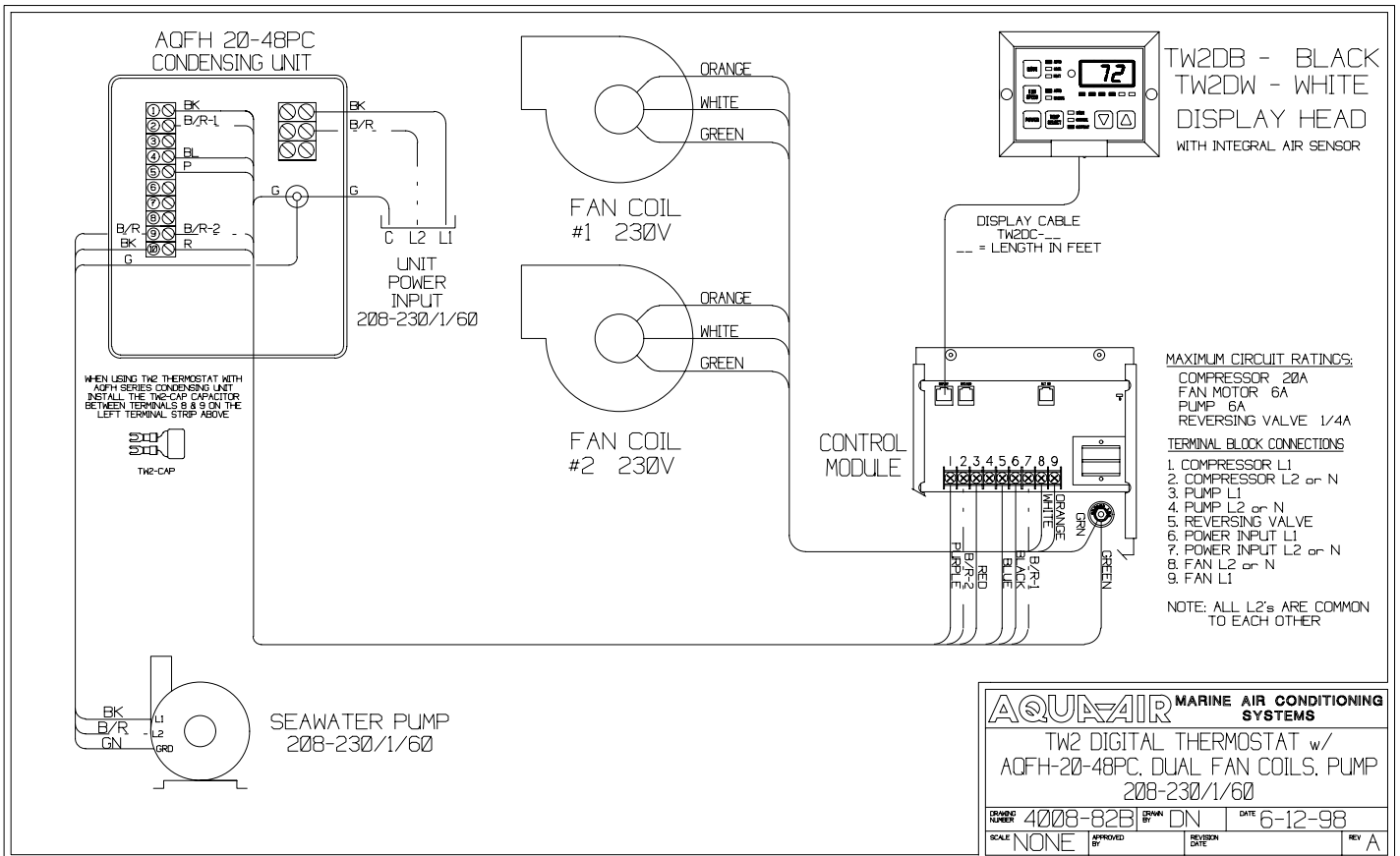
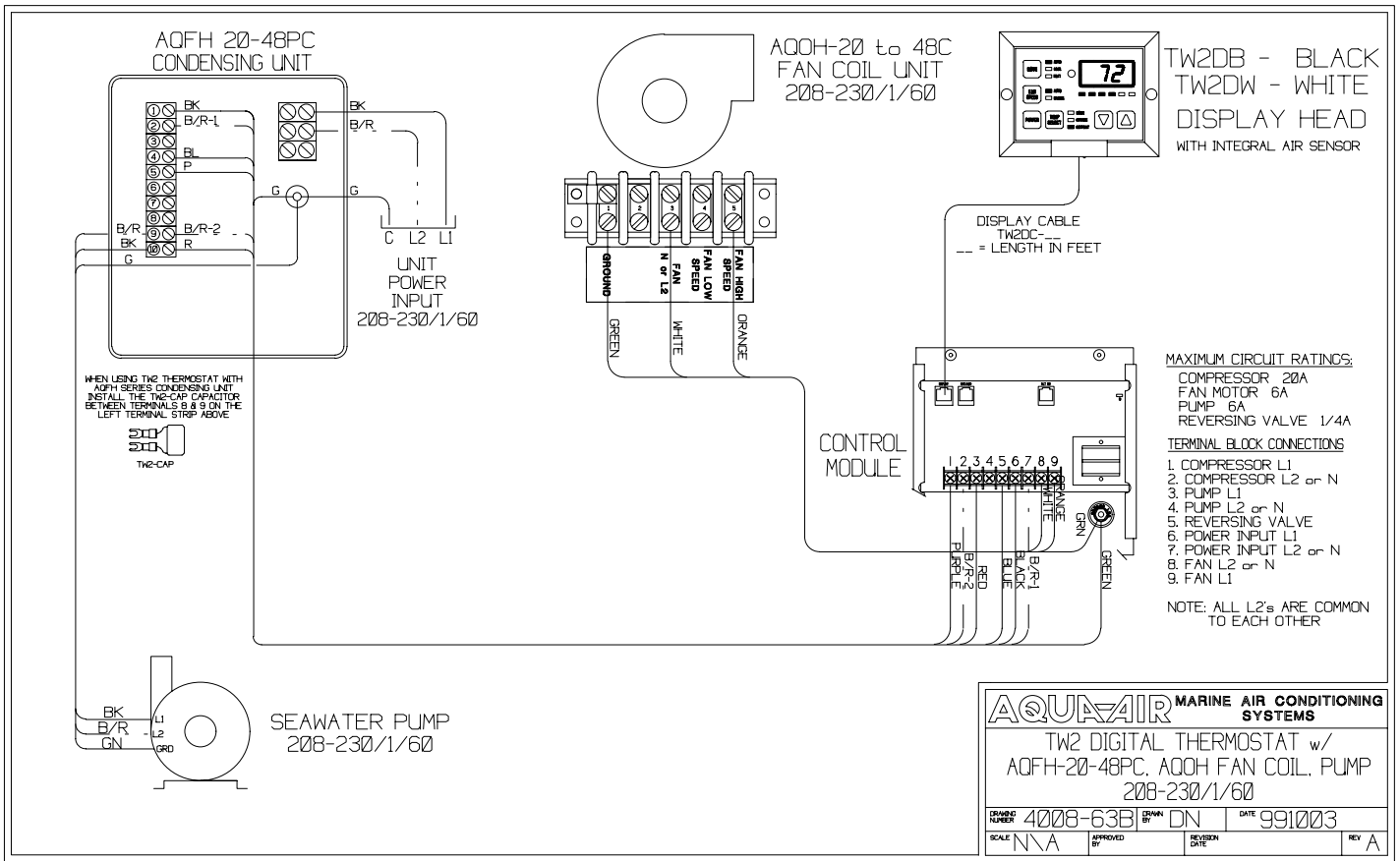

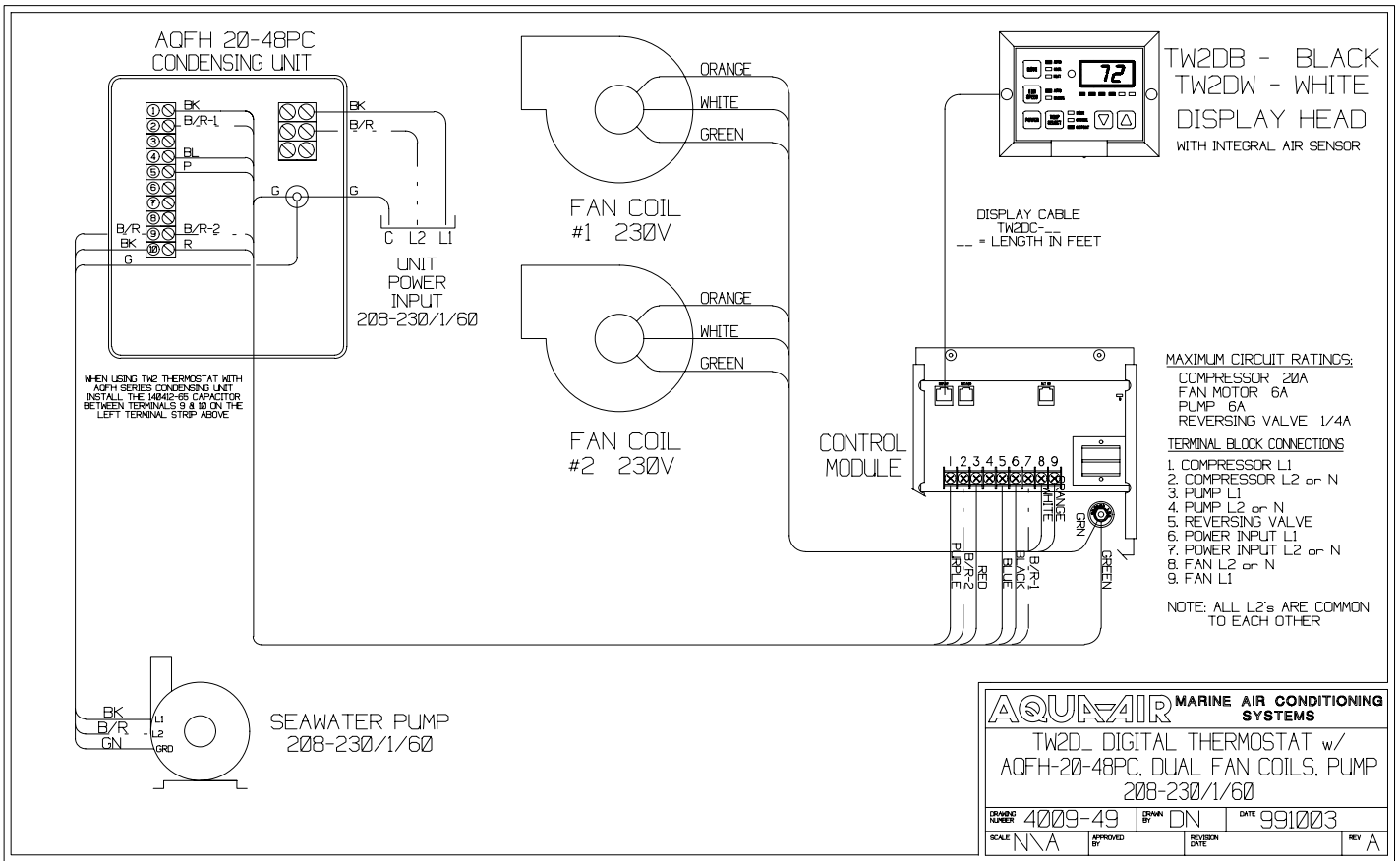

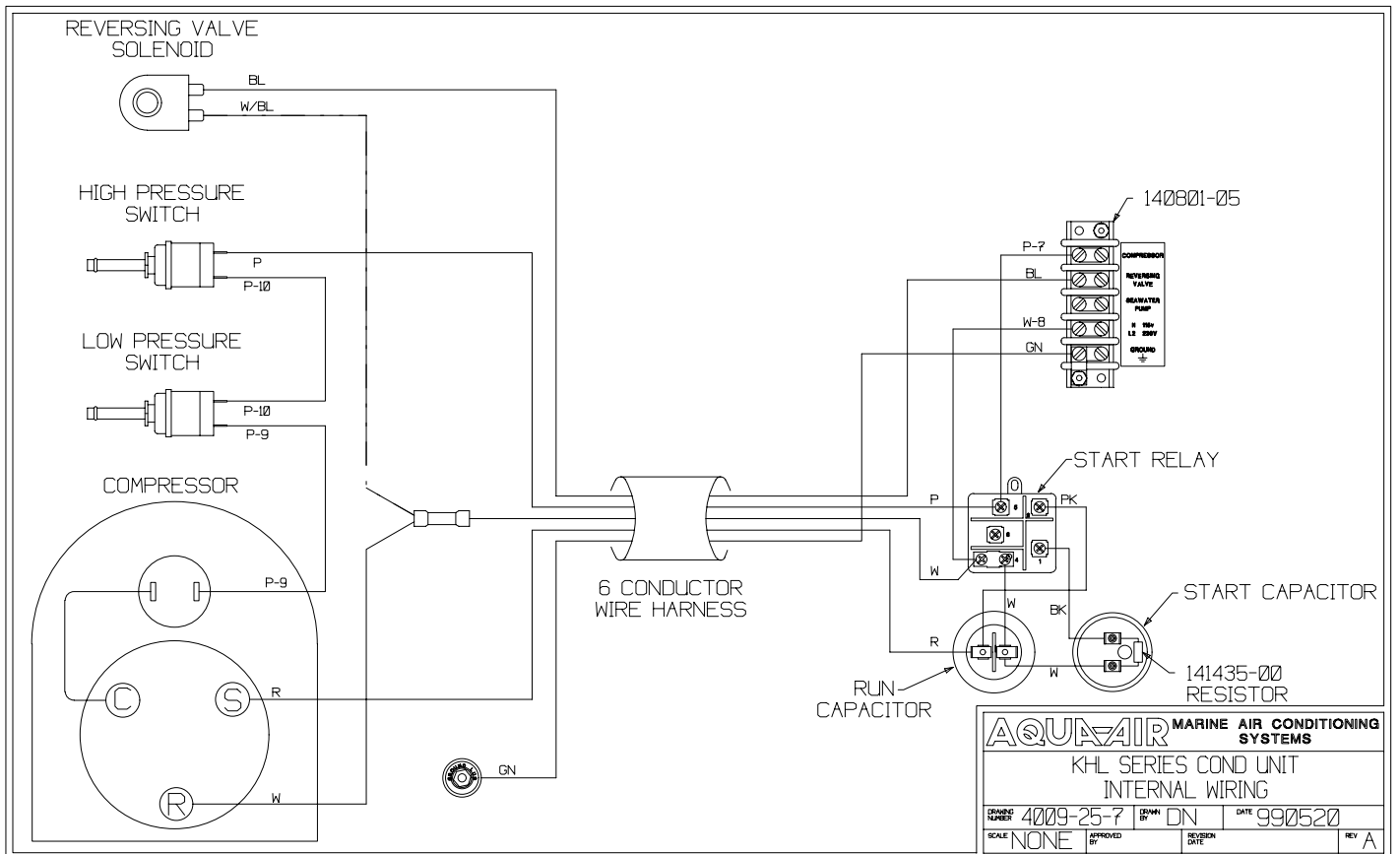
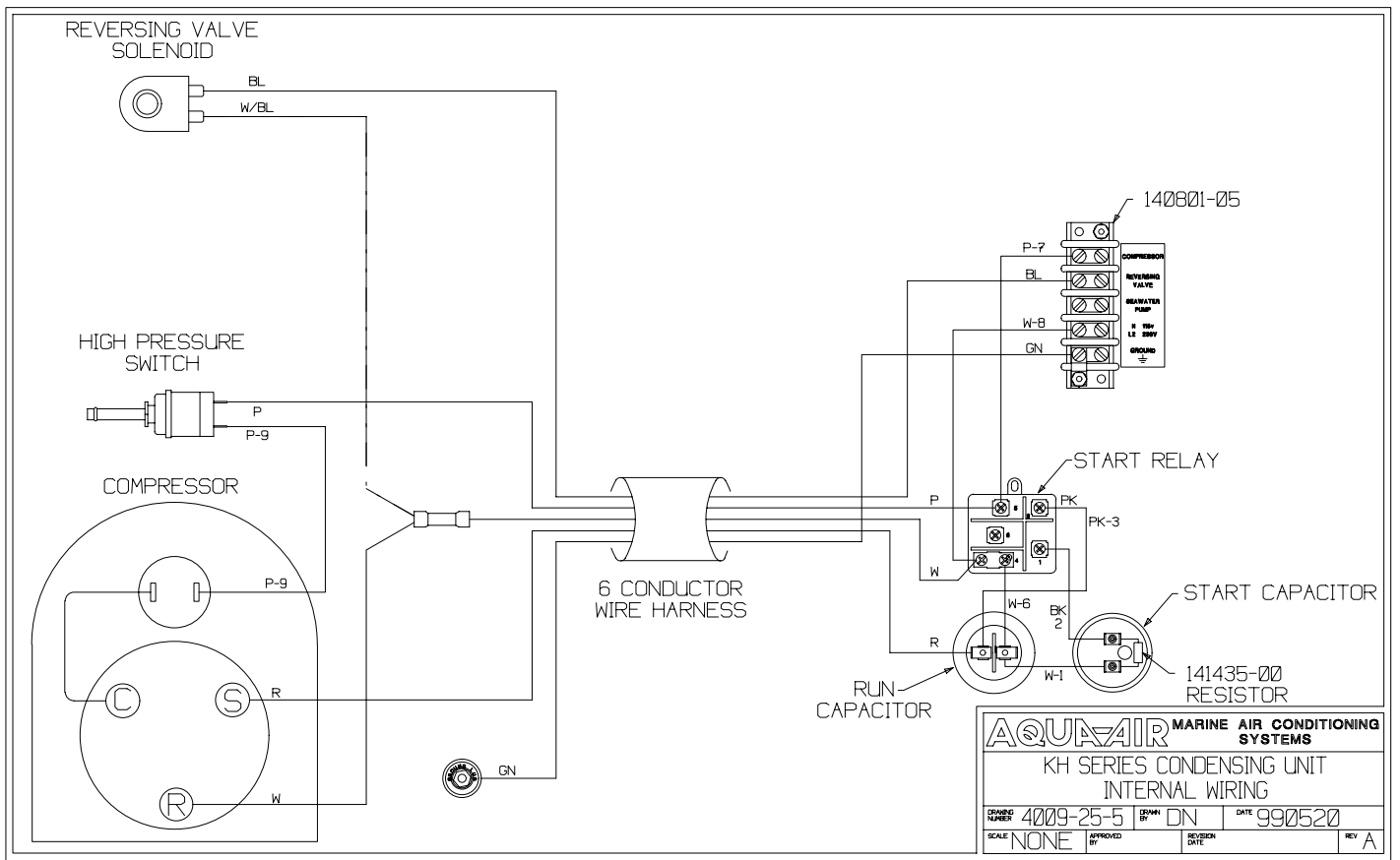

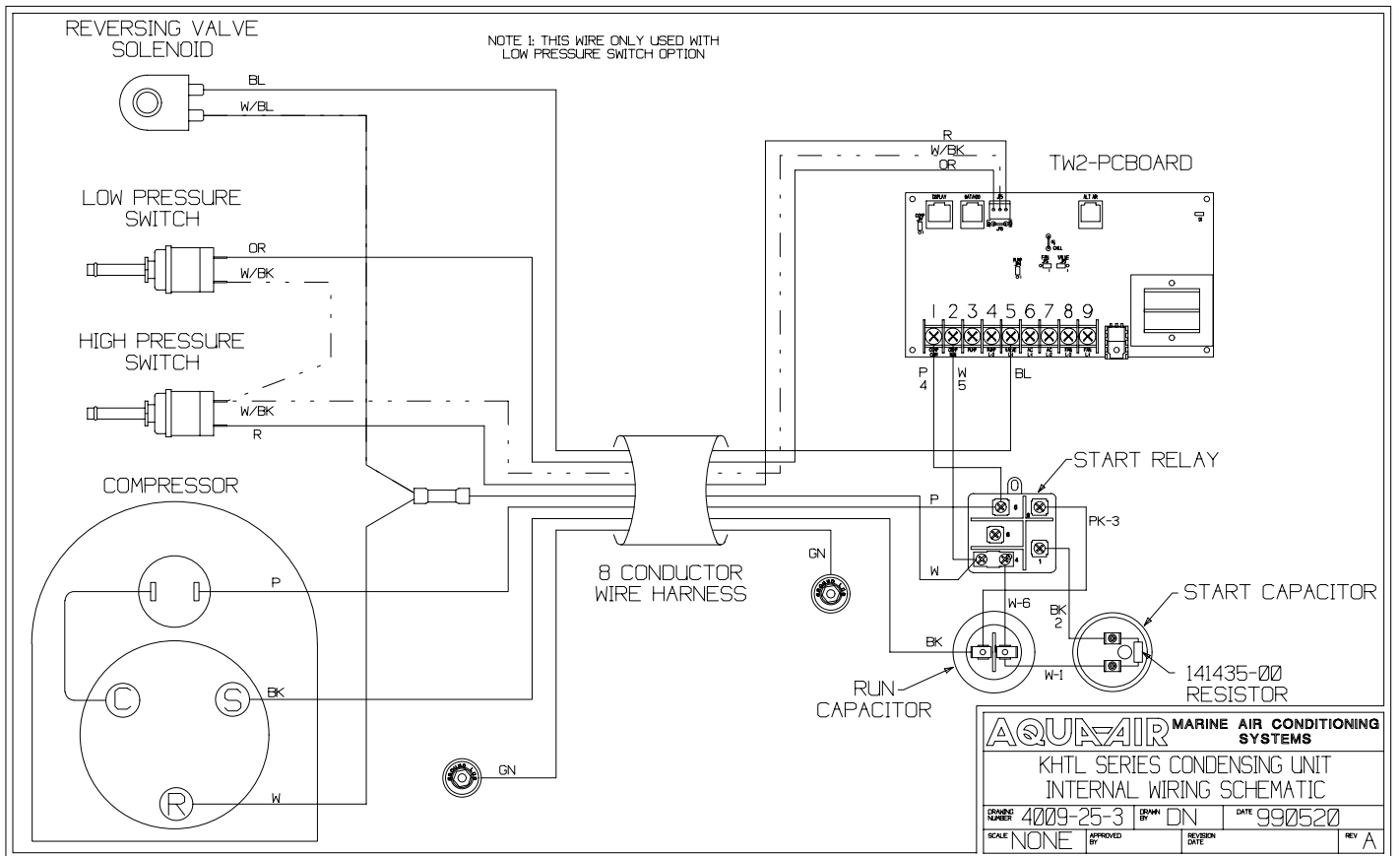
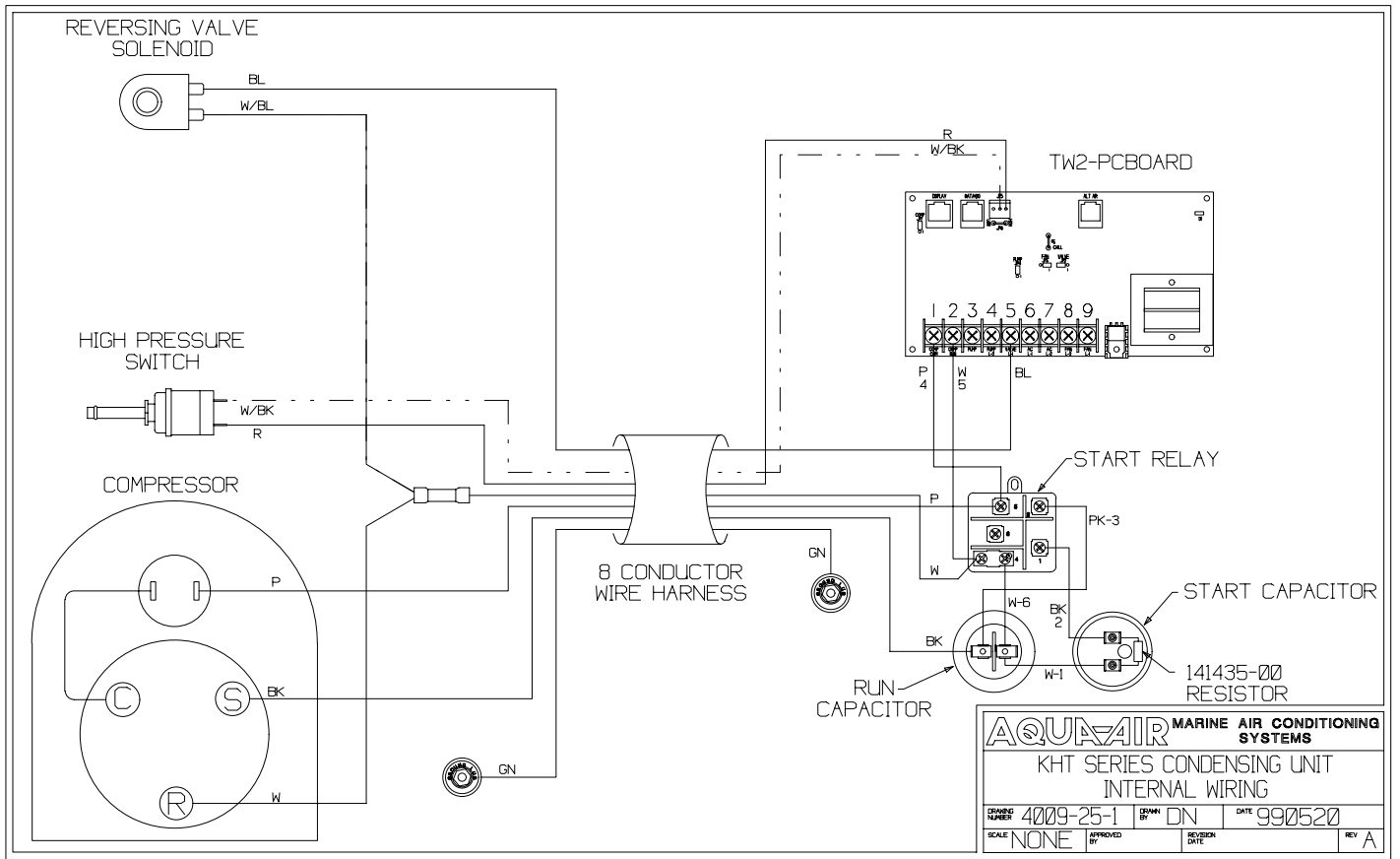

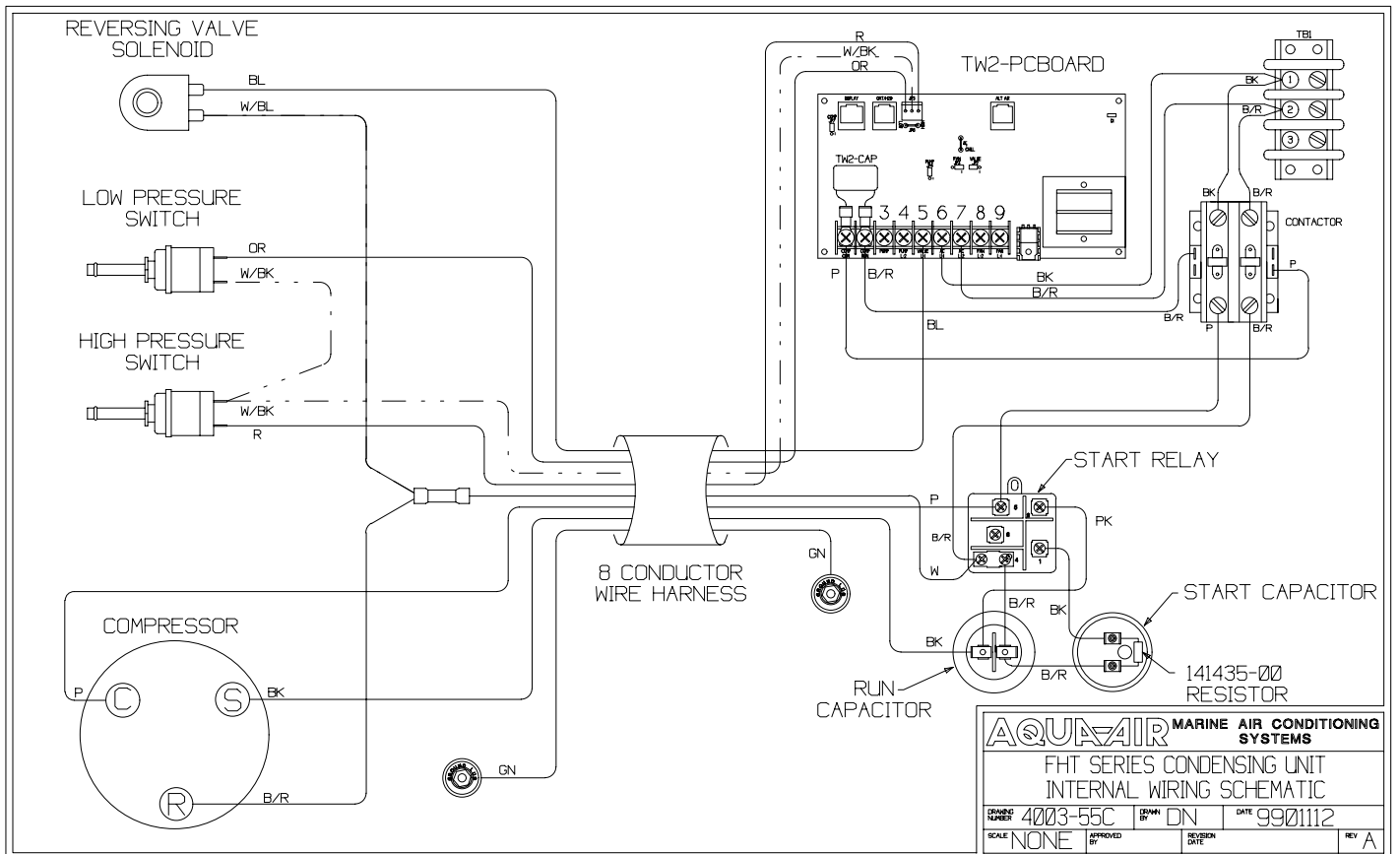
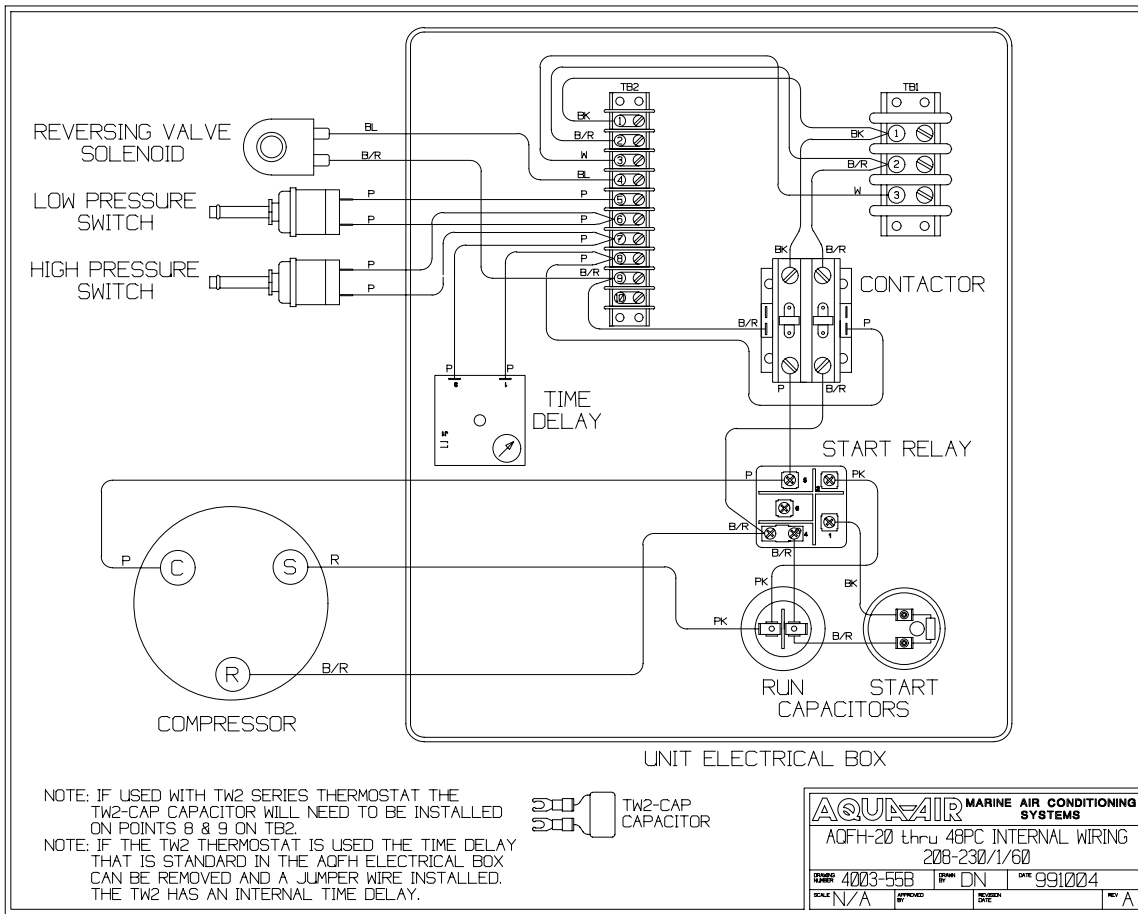

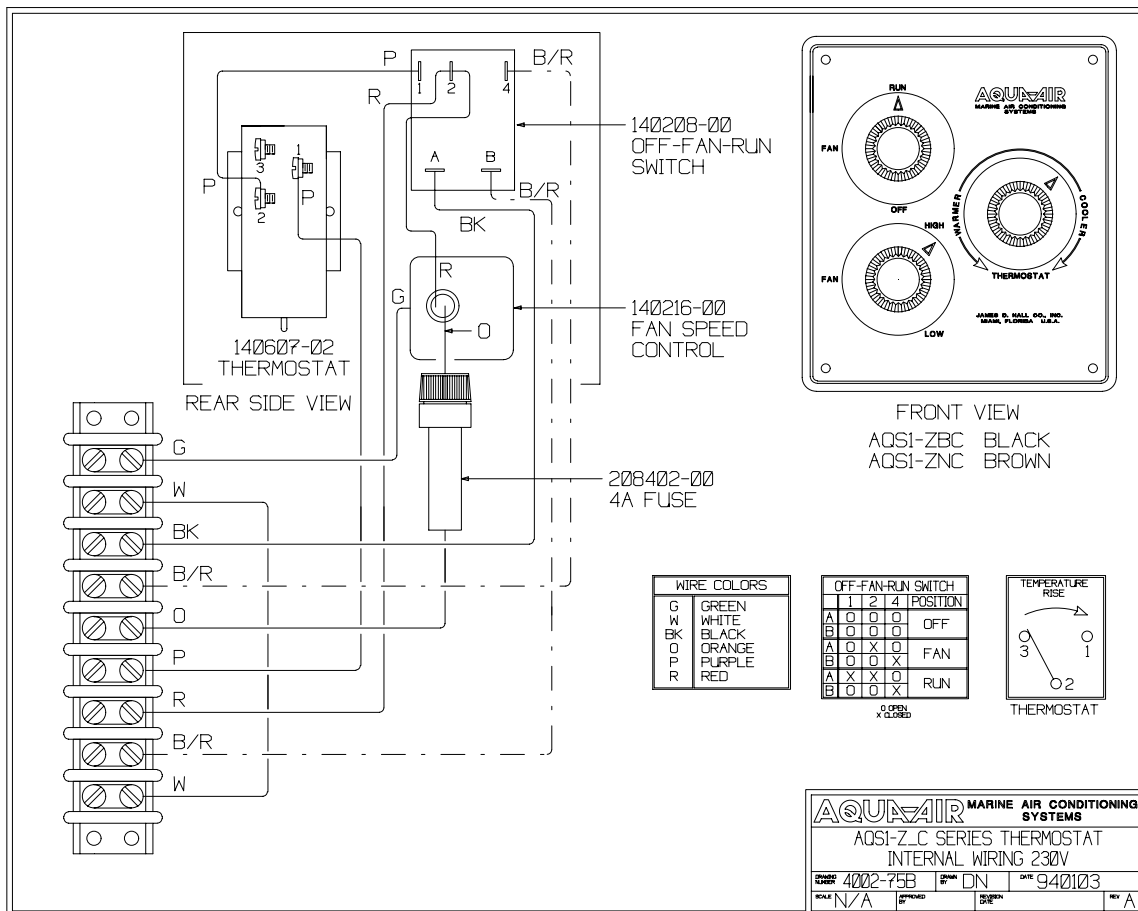
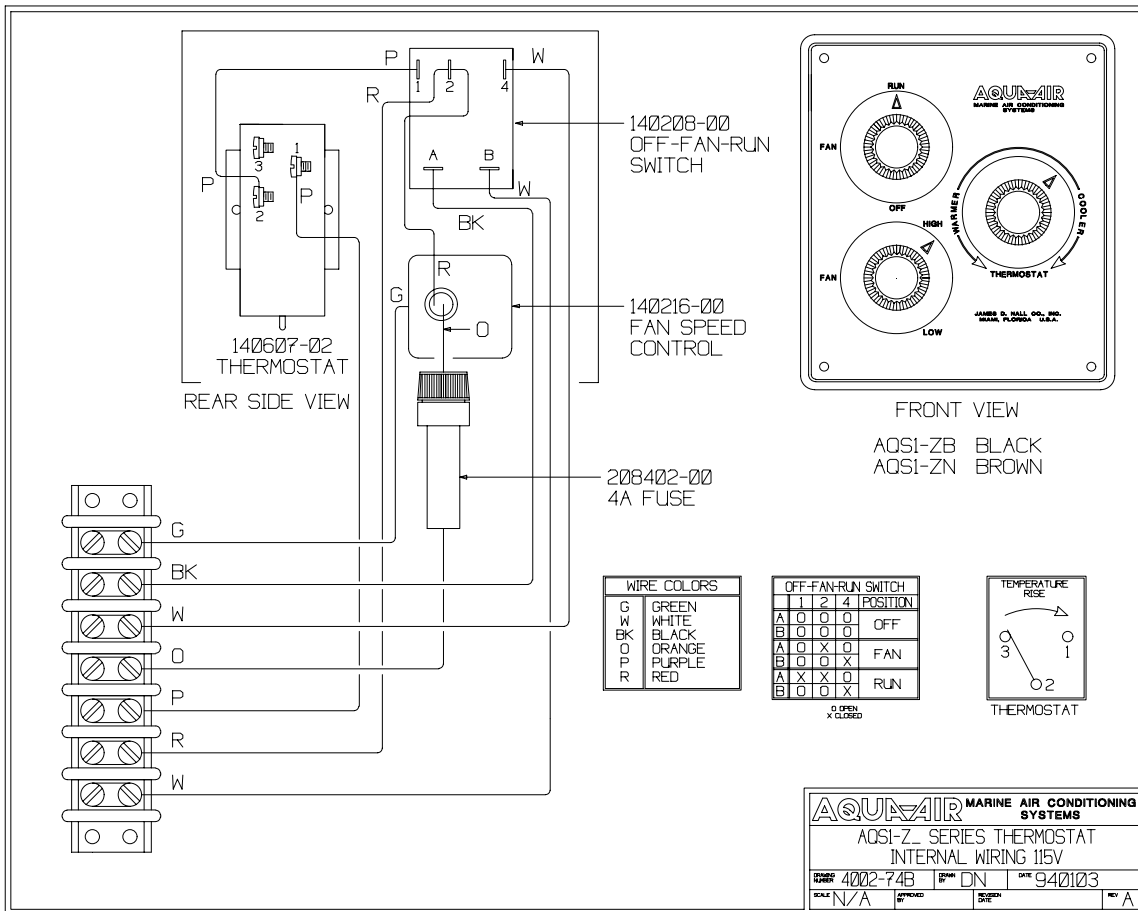

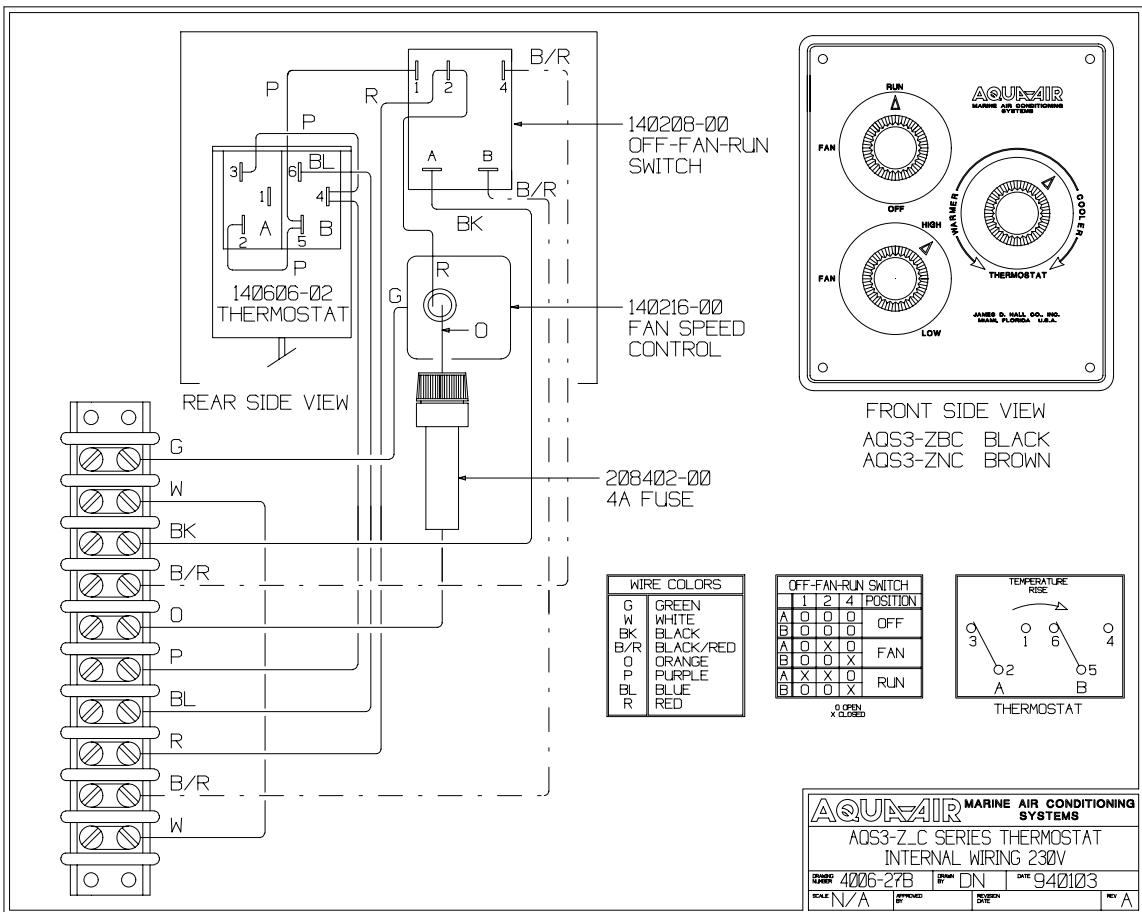
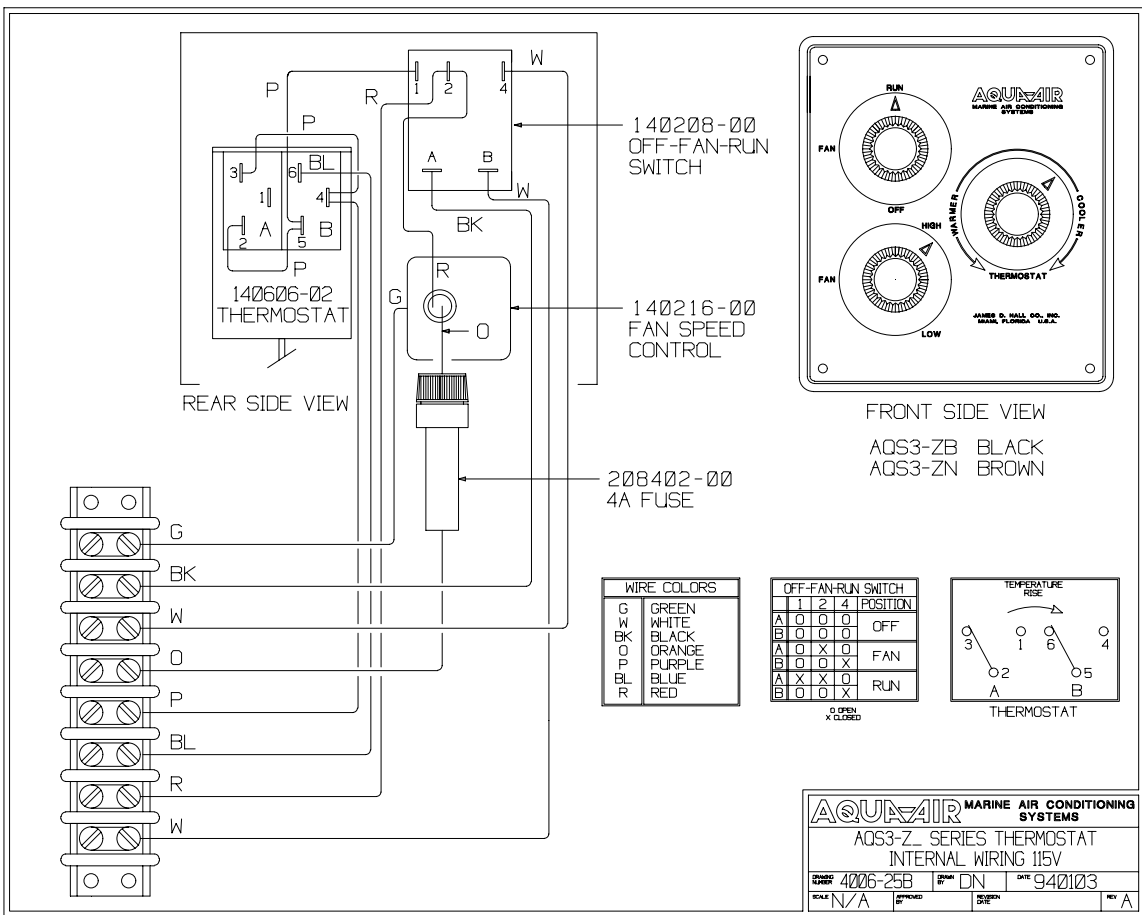

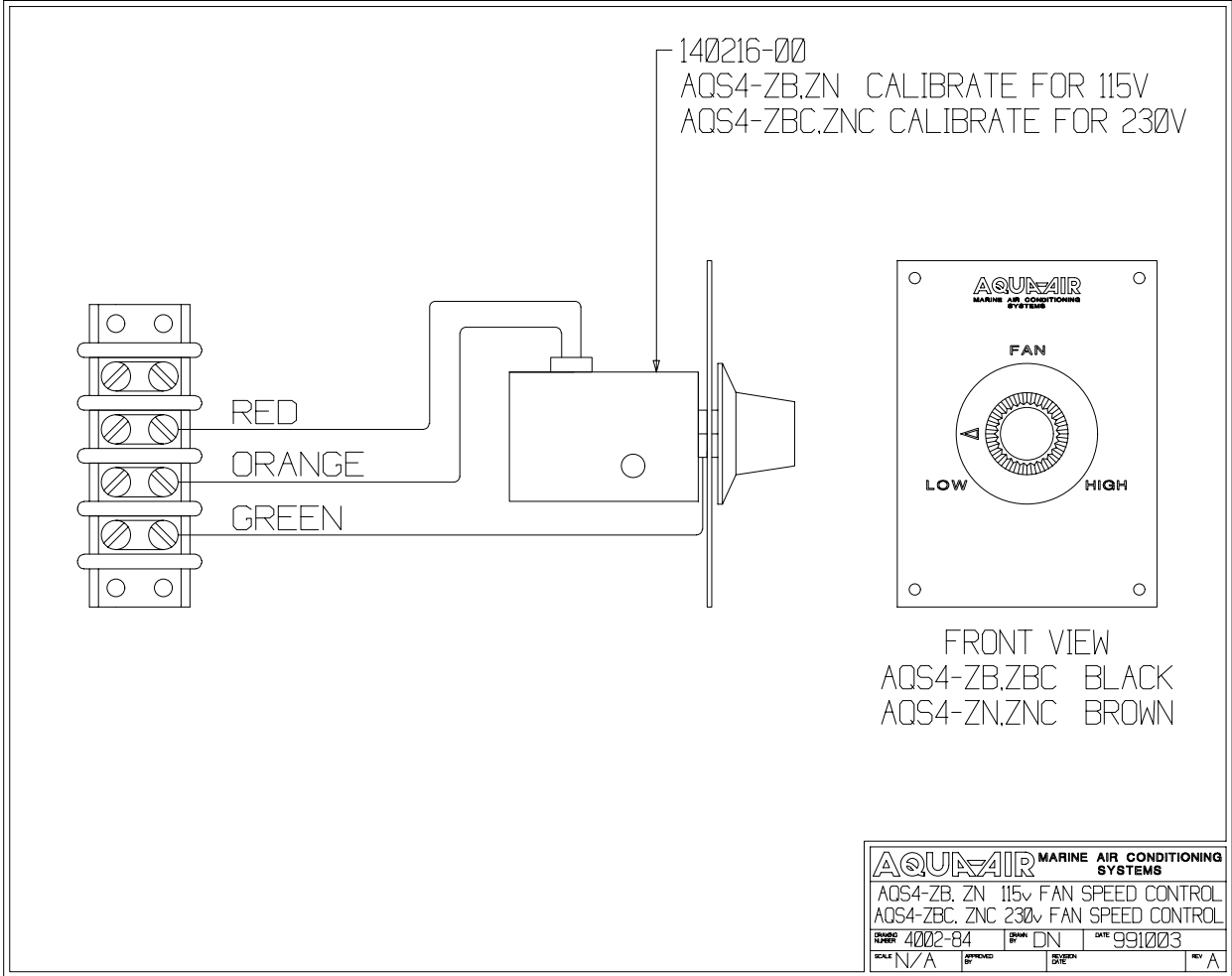



DX PRODUCT LIMITED WARRANTY PERIODS

The warranty period on all Aqua-Air DX (Direct Expansion) products is **one year**. Parts and labor are covered per warranty allowance schedules.

For new Aqua-Air DX system installations using **TW2** microprocessor controls, parts will be warranted for an additional year. All equipment in the system, including pumps, pump relays and associated parts will be covered for **two years**.

The TW2 microprocessor controls used in a retrofit on Aqua-Air or any other manufacturer's marine air conditioning equipment will carry a one year warranty. New TW2 controls or components of the microprocessor control system purchased to replace out of warranty controls or components will have a one year warranty.

Non-warranty replacement parts and components, other than TW2 controls or components, will be warranted for a period of 90 days. This warranty is for parts only, no labor is included. The exception to this category is replacement compressors which carry a one year warranty, including parts and labor from the date they were sold.

Parts and components supplied by Aqua-Air Manufacturing for replacement on any Aqua-Air unit under warranty will be warranted for the remainder of the original warranty period only.

Replacement parts or components used on competitors equipment will have a 90 day warranty. The exception is those parts used in the refrigeration circuit of any competitive brand of air conditioning equipment, which will carry no warranty.

All warranties begin when the customer takes possession of the equipment. The warranty is extended to all owners of the equipment commencing the date the original owner takes possession of it. Verification of original purchase will be required. All warranties are limited to the terms and periods set forth here. Any and all implied warranties are excluded.

Fuses and MOV's are used as safety devices to protect Aqua-Air equipment against over-voltage conditions caused by induced lightning or inductive switching environments. These are not covered under warranty.

Aqua-Air will repair or replace, at its option, components found to be defective due to faulty materials or workmanship, after the component has been examined by Aqua-Air or its authorized servicing dealer. Additionally, Aqua-Air will pay labor costs, as outlined in its Schedule of Limited Allowances, for the removal and replacement of the component. This limited warranty extends to Aqua-Air DX products that have been installed, operated and maintained in accordance with written guidelines available from Aqua-Air.

Aqua-Air reserves the right to change its warranty policies and procedures as well as its warranty allowances without notice.

Aqua-Air equipment is designed and manufactured for long term, trouble free operation when properly operated and maintained. It is strongly recommended that you read your owners manual and fully understand the operations of your Aqua-Air equipment. Any questions you have regarding the operations of your Aqua-Air system or warranty coverage can be directed to your authorized Aqua-Air dealer or to Tech Support at Aqua-Air Manufacturing (800) 457-3928.

G:\DX Dealer Handbook\80105-3a.WPD rev 1/00

i:\wordpfct\80105-1a,2a,3a.wpd

***AQUA-AIR MANUFACTURING, division of the James D. Nall Co., Inc.
1050 East 9th Street, Hialeah, Florida 33010 U.S.A.
Ph. 305-884-8363 Fax 305-883-8549 E-mail sales@aquair.com***