

AQUA AIR

MARINE AIR CONDITIONING
SYSTEMS

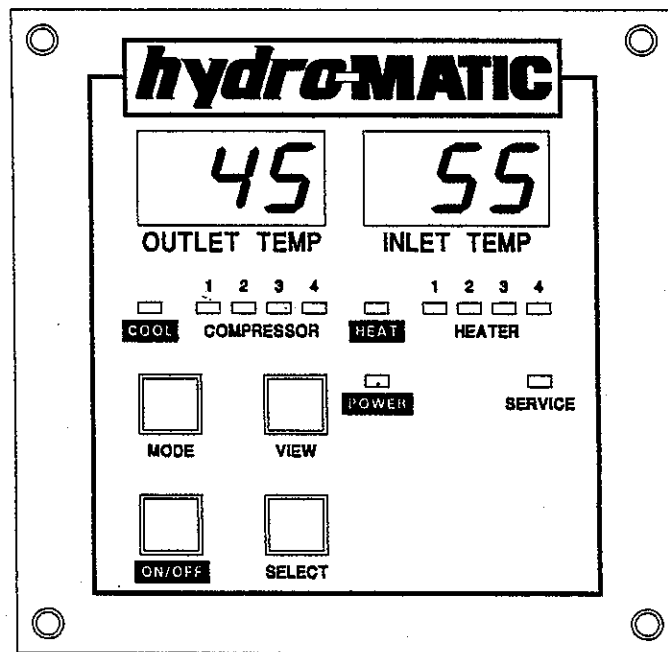

HYDROMATIC CHILLER CONTROL OPERATIONS MANUAL

Contents

Introduction1
System Features1
Operator Controls & Display Panel2
Modes of Operation4
Using the Hydromatic Control.4
Program Mode5
Programmable Parameters7
Theory of Operation	11
Fault Detection & Failsafe Protocols	17

80969-01.wpd

AQUA-AIR MANUFACTURING, division of the James D. Nall Co., Inc.
1050 East 9th Street, Hialeah, Florida 33010 U.S.A.
Ph. 305-884-8363 Fax 305-883-8549

List of Figures

1: Hydromatic Display Panel.2
2: Heating & Cooling Cycles.11
3: Typical Cooling Cycle (Reverse Cycle Units)13
4: Typical Heating Cycle (Reverse Cycle Units)14
5: Typical Cooling Cycle (Immersion Heat Units)15
6: Typical Heating Cycle (Immersion Heat Units)16

List of Tables

View Mode Displays5
Hydromatic Programming Quick Guide7
Sensors Equipped Programming Table10
Failsafe and Fault Handling17

INTRODUCTION

Hydro-matic HMC-1 is a microprocessor-based digital thermostat designed to control chilled water systems. The HMC-1 is capable of controlling multi-stage compressor and heater outputs. This document supports the two models available: the **2-Station Hydro-matic** (1 to 2 stage compressor/heater) and the **4-Station Hydro-matic** (1 to 4 stage compressor/heater). Each control is available in either **reverse cycle** or **chill cycle** for 120 VAC or 240 VAC. The Hydro-matic is factory configured to customer specifications for operating voltage, cycle functions (reverse or chill) and the number of compressor stages.



IMPORTANT: Verify that the **Programmable Options** meet your specific system requirements *before* powering up your system.

SYSTEM FEATURES

Staging Delays

Microprocessor controlled staging delays insure that all the complex inter-timing functions of the system are automatically maintained.

Separate heating and cooling modes

By the push of a single button, the system automatically switches all external hardware to the desired Mode (heat or cool).

Programmable protection level

The failsafe level can be programmed to fit individual requirements.

User configurable output voltage

The external contactors circuits used to control the actual compressors and heaters can be made to be any voltage from 12 VAC to 120 VAC for low voltage outputs where safety and cost are major considerations.

User Over-ride switches

The user can over-ride the control systems by simply enabling or disabling any combination of the controlled hardware. A multi-colored LED indication is supplied when this function is in use.

Dual Display Capability

As with many large vessels it may be advantageous to have one display in the Captain's or Engineer's quarters and another locally at the system's site. Hydro-matic can support two control panels for convenient use in remote locations.

Automated valve unloading

The Hydro-matic unloads the head pressure of the compressor via the optional unloading valves, enabling easier compressor starts.

Intelligent compressor sequencing

The Hydro-matic sequentially rotates the use of the leading or starting compressor in order to equalize each compressor's cumulative run time.

Failed compressor bypass

The Hydro-matic will automatically bypass and replace a failed compressor stage and will continue to compensate staging functions while maintaining cooling or heating operations.

OPERATOR CONTROLS & DISPLAY PANEL

Please refer to *Figure 1: Hydro-matic Display Panel* for the following discussion:

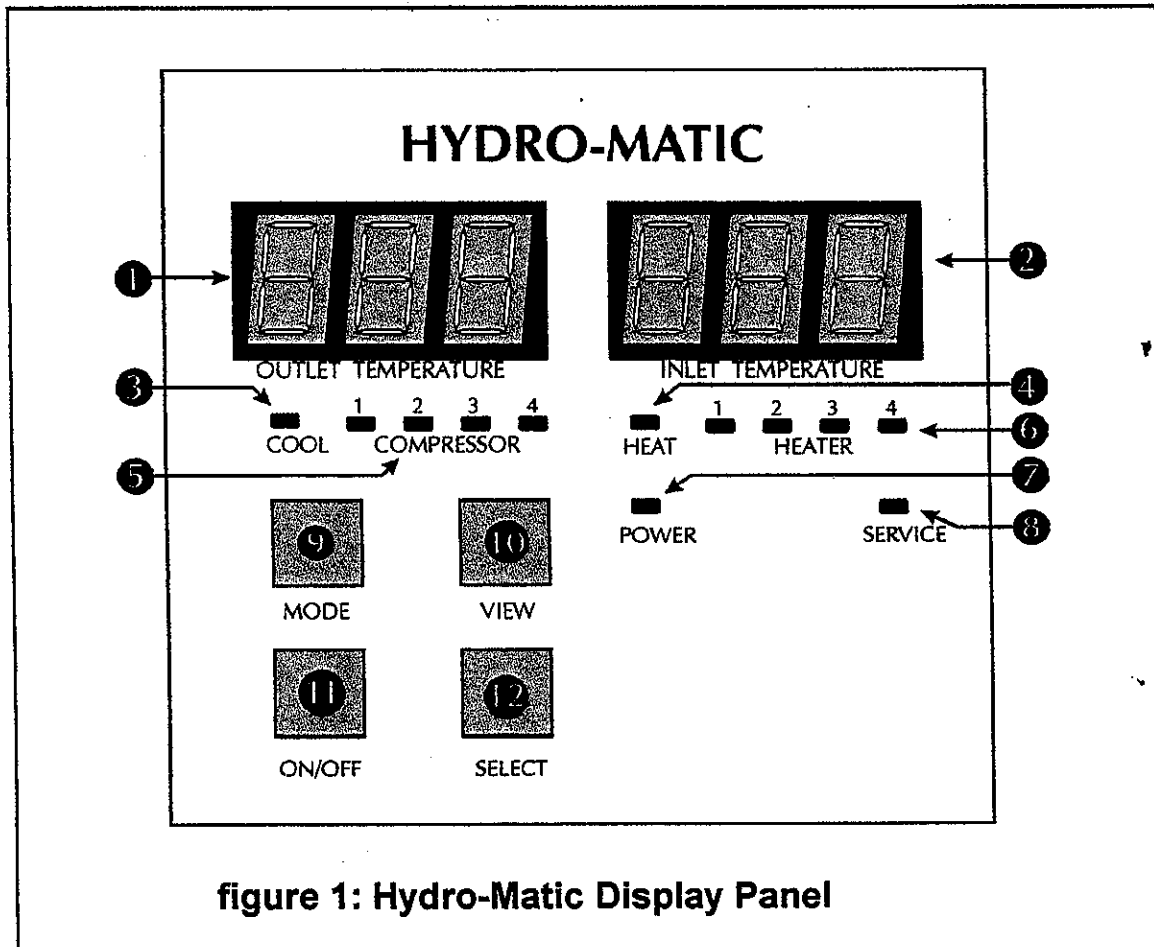

figure 1: Hydro-Matic Display Panel

1. Outlet Temp Display

The seven segment LED display indicates **outlet water temperature**, program function (in **Program Mode**) and sensor information (in **View Mode**).

2. Inlet Temp Display

This seven segment LED display indicates **inlet water temperature**, program parameter value (in **Program Mode**) and sensor readings (in **View Mode**).

3. Cool LED

When this LED is illuminated, the Hydro-matic is in **Cool Mode**.

4. Heat LED

When this LED is illuminated, the Hydro-matic is in **Heat Mode**.

5. Compressor LEDs

These LEDs indicate the active states of the compressors in the system.

6. Heater LEDs

These LEDs indicate the active states of the heaters in the system.

7. Power LED

When this LED is illuminated, it indicates that the Hydro-matic is operational (in the **On Mode**).

8. Service LED

When this LED is illuminated, it indicates that the Hydro-matic has detected a fault condition.

9. MODE Button

This button switches between **Cool** and **Heat Mode**.

10. View Mode

This button is used to view the sensor status in **On Mode**. In **Program Mode**, this button is used to select the programmable items.

11. ON/OFF Button

This button turns the control on and off. It is also used to enter **Program Mode** and to initialize Factory Default Values.

12. SELECT Button

This button changes the program values in **Program Mode**, is used to exit **View Mode**, and removes flashing fault codes from the display.

Control Board Switches and Indicators

There are 14 Override Switches on the Hydro-matic Control Board; one for each output. These switches are three position switches. Accompanying these switches are multi-color LED indicators that show what position the switch is in.

Placing an Override switch in the **Green** position sets the output for **Automatic** or normal operation. The center **OFF** position sets the output to **OFF** or De-energized state. Placing the switch in the position **Red** sets the output to **ON** or energized state.



IMPORTANT: *Extreme caution must be exercised when switching the override switches while the system is powered on!* Improper random staging or improper settings can result in extreme electrical current loading and possible electrical damage. These switches should only be used by experienced personnel with a deliberate plan of intent.

MODES OF OPERATION

Off Mode

When the Hydro-matic is in the **Off Mode**, all control outputs will be turned off, and the display will be quiescent. **Restoring Factory Defaults** and **Program Mode** can only be accessed via **Off Mode**.

On Mode

This is the primary operating mode of the Hydro-matic. Power will be supplied to the appropriate outputs as required, and all the other modes are accessible to the user. Temperatures in the display will be updated every ten (10) seconds for small changes, but responds immediately for large changes.

Cool Mode

When the Hydro-matic is in **Cool Mode**, the system will provide cooling when required

Heat Mode

Selecting **Heat Mode** causes the hydro-matic to provide heating when required.

View Mode

View Mode allows the user to examine the system's sensors and line voltage.

Program Mode

Program Mode allows the user to change any of the various program settings.

USING THE HYDRO-MATIC

To Turn the Unit On



Press the **ON/OFF** button once. This toggles the Hydro-matic from the **Off Mode** to the **On Mode**. The panel displays will light, indicating that the unit is ready for operation.

To Turn the Unit Off



Press the **ON/OFF** button once to toggle the Hydro-matic from the **On Mode** to the **Off Mode**.

Selecting Cooling or Heating



Pressing the **MODE** button toggles between **Cool** and **Heat** modes. The Cool or Heat LED will be lit, indicating which mode is currently selected. Only one of these modes can be active at a time.

Using View Mode



Enter **View Mode** by pressing the **VIEW** button. View mode will sequentially display each installed item as indicated in *Table 1*.

The sensor number is displayed in the **OUTLET TEMP** display, and the sensor reading is displayed in the **INLET TEMP** display. Only sensors that are actually equipped are displayed.

Table 1: View Mode Displays

Sensor	Left Display (Outlet Temp)	Right Display (Inlet Temp)
Comp. Water Temperature	C - (1-4)	Temperature
High Freon Pressure	H P (1-4)	1 = Contact Closed F = Sensor Open
Low Freon Pressure	L P (1-4)	1 = Contact Closed F = Sensor Open
Low Oil Pressure (see note pp.19)	O P (1-4)	1 = Contact Closed F = Sensor Open
Line Voltage	A - C	Voltage



To exit **View Mode**, press the **SELECT** button. The Hydro-matic will automatically exit **View Mode** if no buttons are pressed for 30 seconds.

PROGRAM MODE

The **Program Mode** is used to view and/or change the user-programmable options. The Hydro-matic is shipped with **Factory Default Settings** of these programmable parameters which are stored in permanent memory, and can be recalled at any time.



IMPORTANT: The Factory Default Settings may not be compatible with your equipment! If you need to customize the default parameters, fill out the form at the end of this manual.

NOTE

Note: Severe electrical disturbances can sometimes upset the Hydro-matic's operating sequences. Operator confusion related to program parameters can also cause what seem to be operational problems.

Whenever there is any doubt as to the proper operation of the Hydro-matic control unit, factory default parameters should be initialized.



Important: It is important to insure that the system has been shut down prior to programming the Hydro-matic to avoid any electrical problems. During the programming session, all control outputs are switched off automatically. If any program parameters are changed, the unit will perform a power-on reset before powering back up.

Entering Program Mode

The Program mode can be entered from **Off mode** *only*. *Table 2: Programming Quick Guide* provides information about the programmable options available, factory default values and the allowable range for each setting.



To enter program mode, press and hold the **ON/OFF** button until a "P" appears in the **Outlet Temp** display [approximately 4 seconds]. Release the button at this time and the first program menu item will appear in the **Outlet Temp** display ("P 1"). The **View** button is used to sequentially display each program item.

Using Program Mode



The current program settings are displayed in the **Inlet Temp** display. The **Select** button is used to change the program settings: *Pressing and holding the Select button will increment the setting value. Releasing and then pressing and holding the Select button will decrement the program setting value.* The rate at which the program values change will increase after 5 seconds. Releasing the button at the desired value will set the value for that program, and saves the change in permanent memory.

Exiting Program Mode



To exit **Program Mode**, press the **ON/OFF** button once. When exiting, the *Operating Voltage* and the *Firmware Version Number* are displayed. The Hydro-matic will automatically exit **Program Mode** if no buttons are pressed for 30 seconds. The voltage and firmware revision are *not* displayed in this case.

Restoring Factory Default Settings



From OFF Mode ONLY: Initialize the **Factory Default Settings** by *pressing and holding* the **ON/OFF** button until "IP" appears in the **Outlet Temp** display, indicating that the initialization process has been completed. Releasing the button momentarily displays the *Operating Voltage* and the *Firmware Version Number*.

Table 2: Programming Quick Guide

Program Number	Parameter	Default Value	Range		
			Lower	Upper	
P-1	HEAT SET POINT	108° F 42° C	95° F 35° C	118° F 48° C	
P-2	COOL SET POINT	49° F 9° C	42° F 5.6° C	58° F 14° C	
P-3	HEAT STAGING TEMPERATURE	2° F 2° C	1° F 1° C	6° F 3° C	
P-4	COOL STAGING TEMPERATURE	2° F 2° C	1° F 1° C	6° F 3° C	
P-5	STAGING TIME DELAY	60 sec	30 sec	200 sec	
P-6	SERVICE SENSOR HIGH TEMPERATURE LIMIT	135° F 57° C	120° F 49° C	145° F 63° C	
P-7	SERVICE SENSOR LOW TEMPERATURE LIMIT	35° F 2° C	25° F -4° C	45° F 7° C	
P-8	FAILSAFE LEVEL	0 = minimum protection 1 = display only 2 = maximum failsafe	2	0	2
P-9	SEA PUMP OPERATION	0 = continuous pump 1 = cycle with compressor	0	0	1
P-10	NUMBER OF HEATERS EQUIPPED*	4(2)	0 (0)	4 (2)	
P-11	NUMBER OF COMPRESSORS EQUIPPED*	4(2)	1	4 (2)	
P-12	SENSORS EQUIPPED	see program description for details	1	0	7
P-13	LINE VOLTAGE LIMIT	110 V System	80 V	80 V	100 V
		220 V System	180 V	180 V	200 V
P-14	TEMPERATURE UNITS	0 = ° Fahrenheit	USER SELECT	0	1
		1 = ° Celsius			

* NUMBERS IN PARENTHESES INDICATE 2-STATION HYDRO-MATIC SETTINGS AND RANGES

P-1. Heat Set Point

This function sets the temperature for the control to be satisfied when it is in heating mode. In other words, heating is called for when the water temperature falls below this value. It has a range of 95° F to 118° F (35° to 48° C). The factory default setting is 108°F (42°C).



Use the Select button to change the heat set point value.

P-2. Cool Set Point



This function sets the temperature for the control to be satisfied when it is in cooling mode. In other words, cooling is called for when the water temperature rises above this value. It has a range of 42° F to 58° F (5.6° to 14° C). The factory default setting is 49° F (9° C).

Use the Select button to change the cool set point.

P-3. Heat Staging Temperature



This selects the temperature spread for the heaters or compressors when the Hydro-matic is in heating mode. The inlet water temperature has to drop below the **Heat Set Point** *minus* the **Heat Staging Temperature** in order for the first compressor or heater to turn on. (See the section Theory of Operation for a more detailed description of the heating cycle) This function has a range from 1-6°F (1-3°C). The factory default value is 2°.

Use the Select button to change the heat staging temperature.

P-4. Cool Staging Temperature



This selects the temperature spread for the compressors when the Hydro-matic is in cooling mode. The inlet water temperature has to rise above the **Cool Set Point** *plus* the **Cool Staging Temperature** in order for the first compressor to turn on. (See the section Theory of Operation for a more detailed description of the cooling cycle) This function has a range from 1° to 6°F (1° to 3°C). The factory default value is 2°F or C.

Use the Select button to change the cool staging temperature.

P-5. Staging Time Delay



This program adjusts the time delay between the starting of compressors and/or heaters to prevent more than one turning on at the same time. It is the same for both heating and cooling modes. The allowable delay time range is 30 seconds to 200 seconds. The factory default value is 60 seconds.

Use the Select button to change staging time delay.

P-6. Service Sensor High Temperature Limit



The high temperature limit determines the maximum water temperature for the system before a fault condition is flagged. The temperature range for this limit is 120° F to 145° F (49° - 63° C), the factory default value is 135° F (57° C).

Use the Select button to change service sensor high temperature limit.

P-7. Service Sensor Low Temperature Limit



The service sensor low temperature limit determines whether compressors or heaters are to be used in heating mode on reverse cycle applications and if heaters are equipped. The temperature range for this limit is 25° F to 45° F (-4° to 7° C). The factory default is 35° F (2° C).

Use the Select button to change the service sensor low temperature limit.

P-8. Failsafe level

This programming option determines the actions that the Hydro-matic takes upon detection of a fault condition (see section on Failsafe Protocols for specific details of particular faults). There are 3 levels of fail-safe protection provided:

- | | |
|---------|--|
| Level 0 | No failsafe protection
No action taken |
| Level 1 | Service LED Only on Fault Detection
No action taken |
| Level 2 | Maximum Failsafe Protection
Compressor Shut Down on Fault Detection |



The factory default value is protection Level 2. Use the Select button to change the Protection Level.

P-9. Sea Pump Operation

This program option selects whether the sea water pump is on all the time (continuous) or only on when the compressor is on..

0 selects Continuous Pump (factory default).

1 selects Cycle with Compressor.

P10. Number of Heaters Equipped

This setting allows for programming the number of heaters in the system. The range is 0 to 4 (or 2 for 2-station units). The factory default setting is 4 on 4-station hydro-matics (2 on 2-station units).

P11. Number of Compressors Equipped

This setting allows for programming the number of compressors in the system. The allowable range is 1 to 4 (or 2 for 2-station units). The factory default setting is 4 for 4-station hydro-matics (2 for 2-station units).

P12. Sensors Equipped

Use the chart below to determine the correct code to enter for the sensors attached to the system:

Parameter Value	Freon High Pres Sensor	Freon Low Pres Sensor	Oil Pressure Sensor *
0			
1	√	√	√
2	√	√	
3		√	
4	√		
5		√	√
6	√		√
7			√

*see note on page 19

The allowable range of number is 0-7. The factory default is 1.

P13. Line Voltage Limit

This option programs the minimum operating voltage allowed before a low power fault is detected. Valid ranges for this parameter are 80 to 100 VAC (for 110 VAC systems) and 180 to 200 VAC (for 220 VAC systems). The factory default setting is 80 VAC for a 110 Volt system and 180 VAC for a 220 Volt system.

P14. Temperature Units

This option selects either the Fahrenheit or Celsius temperature scales for display.

0 selects degrees Fahrenheit.

1 selects degrees Celsius.

Heating/Cooling Cycles

The Cooling and Heating cycles are controlled by four factors: the inlet water temperature, the current operating mode (Heat or Cool), the programmed setpoint (items P-1 and P-2), and the programmed Staging Temperature (items P-3 and P-4). Please note that there are separate setpoints and staging temperatures for heating and cooling.

The control algorithm is the same for both heating and cooling. In Cool Mode, the control is satisfied when the inlet water temperature reaches the programmed Cool Setpoint (P-2). In Heat Mode, the control is satisfied when the inlet water temperature reaches the programmed Heat Setpoint (P-1).

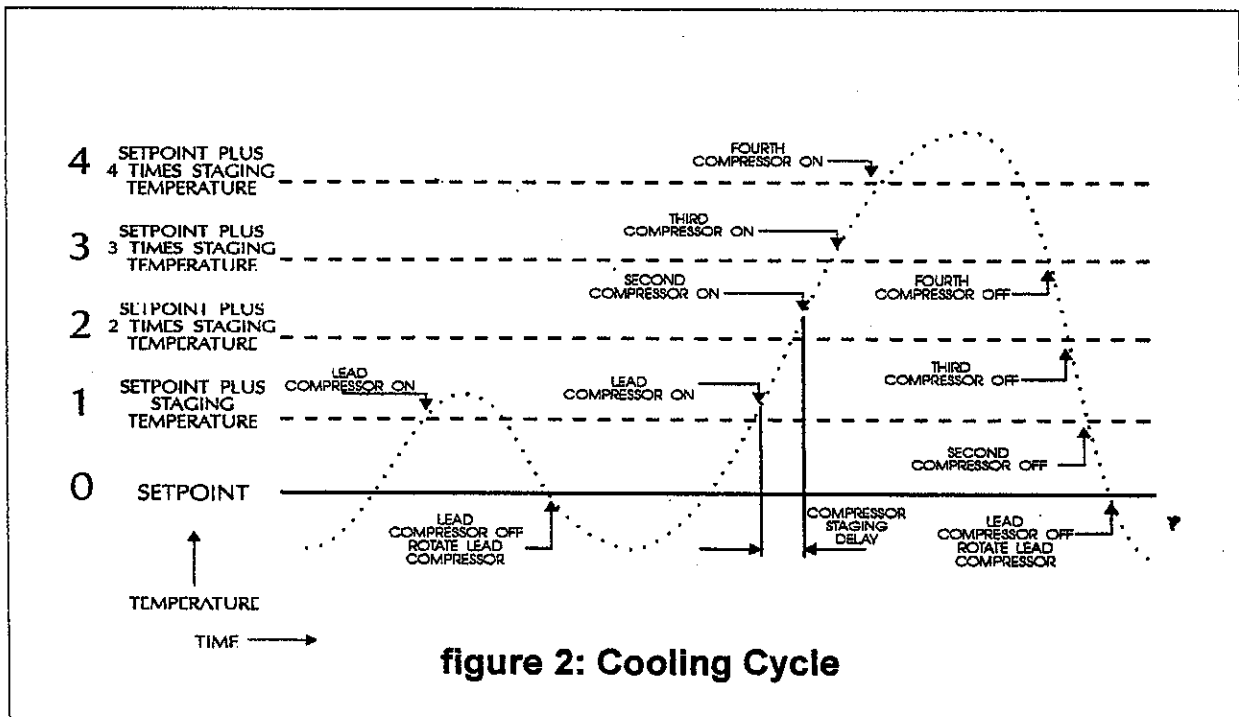

The following discussion assumes system cooling. *Figure 2, Cooling Cycle* illustrates this example. There are four staging levels of cooling. Level 0 corresponds to the programmed setpoint. Levels 1 through 4 are separated by the programmed staging temperature.

The cooling cycle starts when the inlet water temperature rises above Level 1. At this time, a lead compressor is selected and turned on. Once the inlet water temperature reaches Level 0, the compressor will be turned off and the cooling cycle is ended. The lead compressor is changed (advanced) each time to allow for equal use of all compressors. If the inlet water temperature rises above level 2 during a cooling cycle, the Hydro-

matic enables a second compressor. This second compressor will be turned off when the inlet water temperature drops below **Level 1**. The third and fourth compressors are utilized in the same way, being turned on and off as the inlet water temperature rises above and falls below their particular programmed staging temperatures. *Figures 3 through 6* illustrate the system timing of this algorithm under the various heating and cooling modes.

In addition, there is a programmable **Staging Time Delay (P-5)** to prevent more than one compressor (or heater) from turning on at the same time. This programmable staging time is the same for both **Heat Mode** and **Cool Mode**.

The decision to use a compressor or a heater in **Heat Mode** is made by comparing the **condenser sea water temperature** to the programmed **Service Sensor Low Temperature Limit (P-7)**. If the sea water temperature is *above* the limit, then compressors are used. If the sea water temperature is *below* the limit, then heaters are used. Either heaters or compressors are used, never a combination. The Hydro-matic selects the next available compressor (unless a water temperature sensor fault exists) for the temperature test. If no compressors are available, the program shuts down the last compressor enabled for two minutes. After the two minutes, the temperature is tested and the compressor is released for operation. If there are no heaters equipped, then the test for water temperature is not performed and compressors are used for heating at all times.

Electric Heaters [JMP1 & JMP2]

Four (4) station boards equipped with electric heaters and no reverse cycle heat need to have both **JMP1** and **JMP2** jumpers **INSTALLED**. This allows the heaters to follow the loop water temperature requirements without regard to the service sensor temperature. **JMP1** and **JMP2** are located next to the systems one MHz crystal and microprocessor.

The electric heater contactors must be connect the heater outputs on the Hydro-Matic board.

P-10 should be programmed for the correct number of heaters connected.

NOTE... Two Station Boards require jumper **JMP1** **REMOVED** and jumper **JMP2** **INSTALLED** for this same option.

Optional Unloader Valves

The optional unloader valves provide the logic to release residual pressure from the system. Their relative timing logic is illustrated in *Figures 3 through 6* for both Chill cycle and Reverse cycle operating modes. The unloader valves can be directly connected to the Hydro-matic control board without the use of contactors.

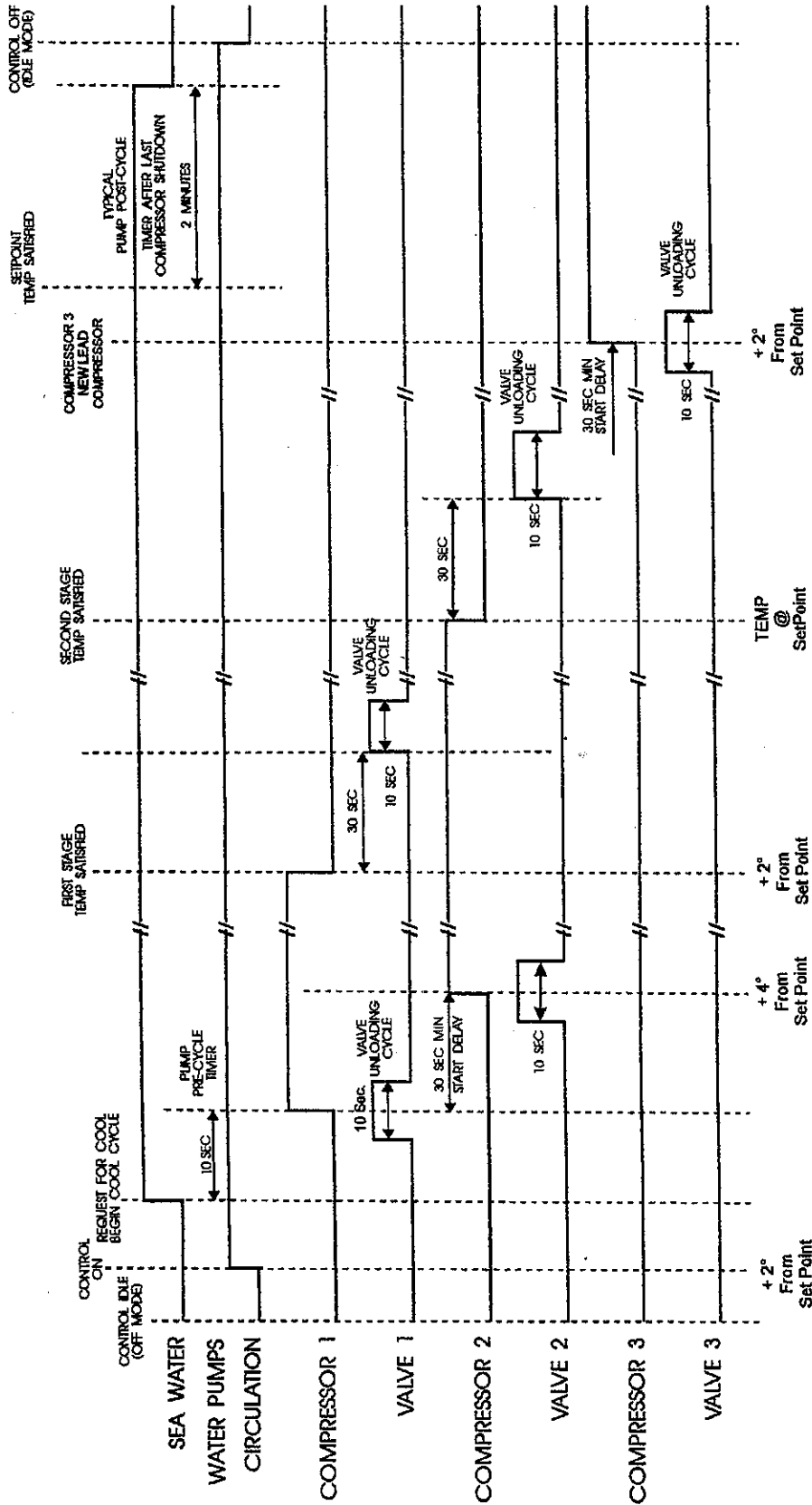

Figure 3: HYDRO-MATIC CONTROL SYSTEM TIMING
(Typical cooling cycle - Reverse Cycle Mode)

Notes:
 1. The lead compressor is automatically rotated. For illustrative purposes, this graph assumes the lead compressor is #1.
 2. A three stage compressor system is assumed in this example cycle.
 3. The sea water pump (P2) is programmed for 'Cycle with Compressor' in this example.

fig 3: System Timing for Reverse Cycle Cooling

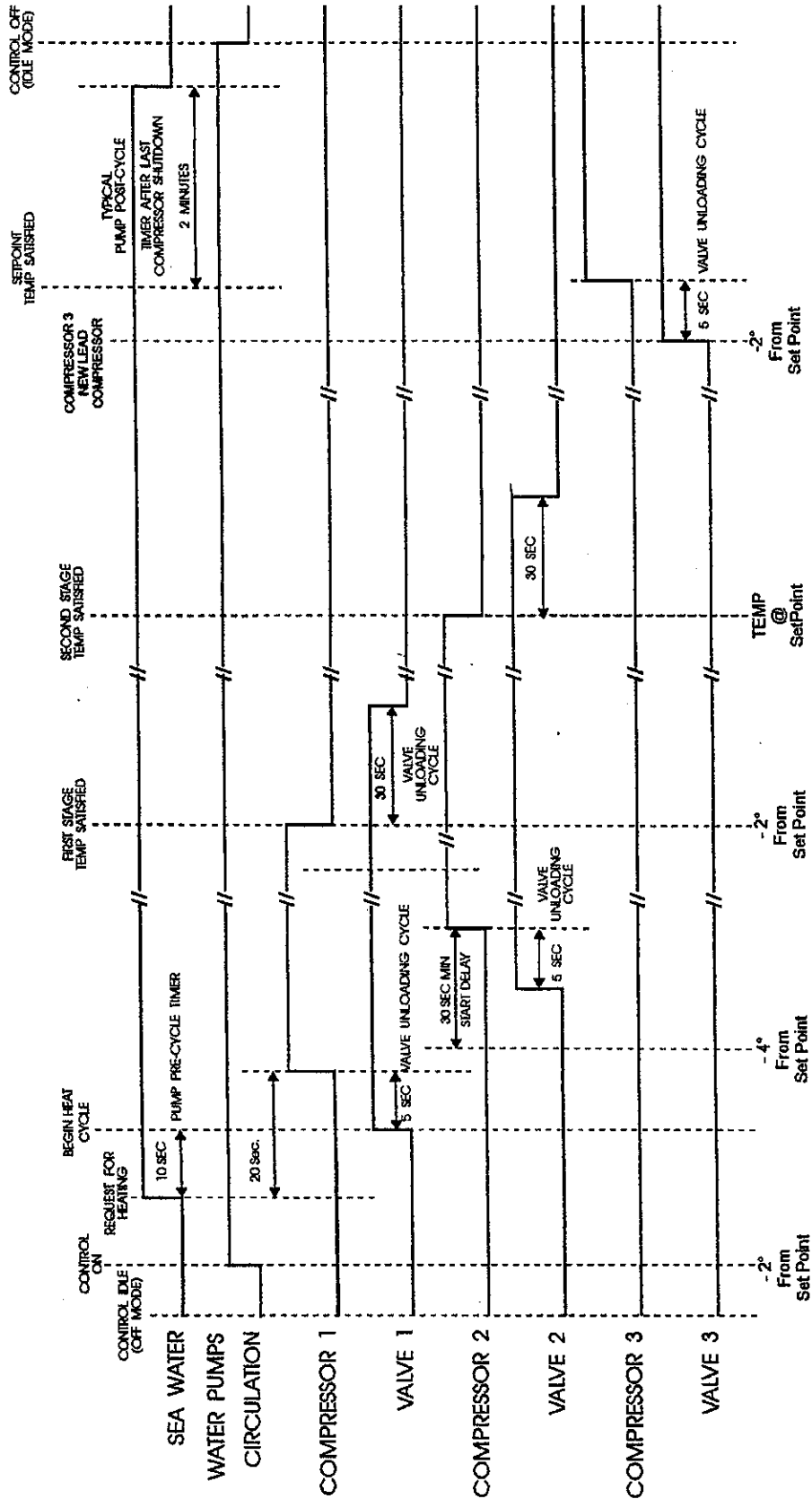

Figure 3: HYDRO-MATIC CONTROL SYSTEM TIMING
(Typical Heating cycle - Reverse Cycle Mode)

Notes:
 1. The lead compressor is automatically rotated. For illustrative purposes, this graph assumes the lead compressor is #1.
 2. A three stage compressor system is assumed in this example cycle.
 3. The sea water pump (P₉) is programmed for 'cycle with Compressor' in this example.

fig 4: System Timing for Reverse Cycle Heating

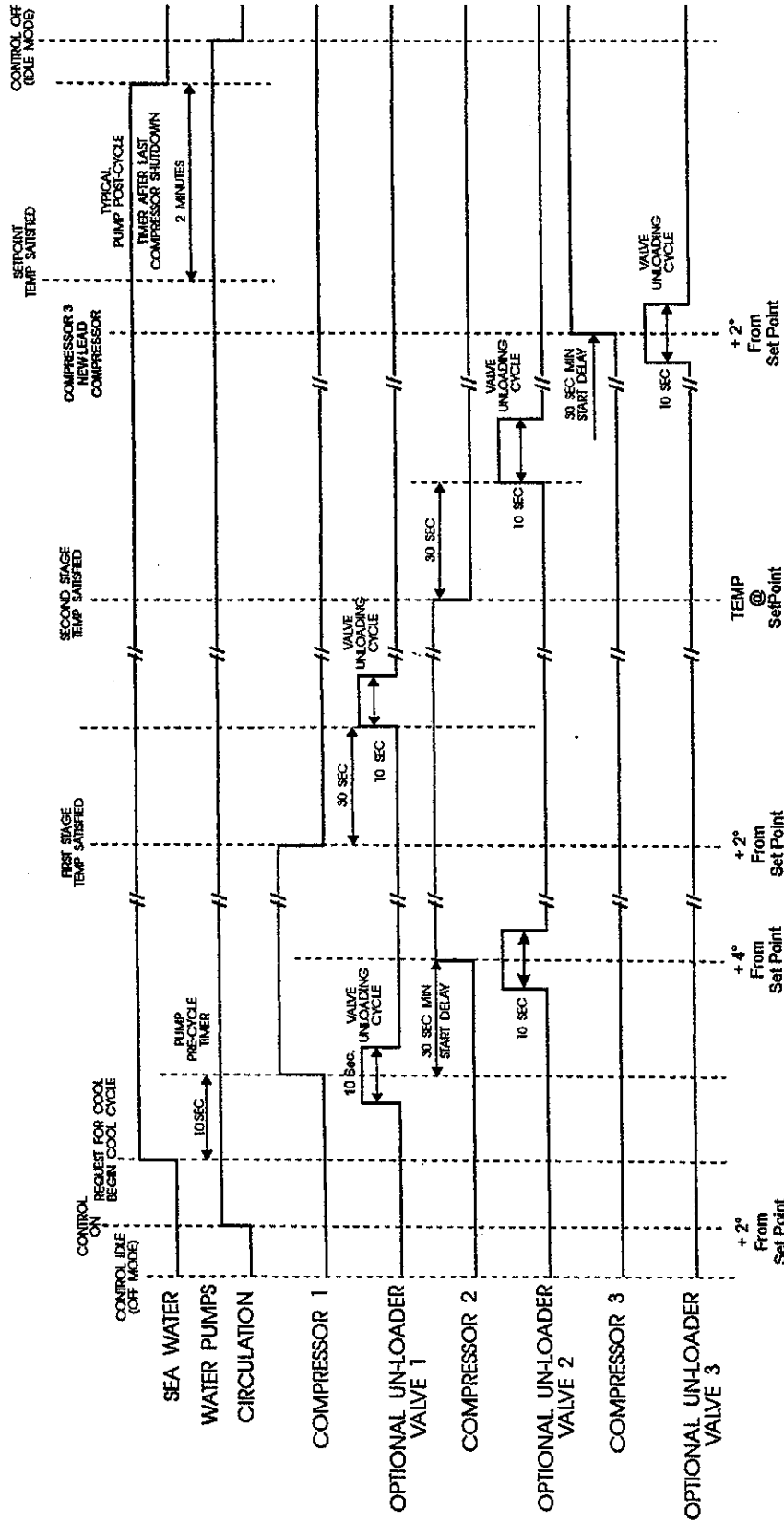

Figure 5: HYDRO-MATIC CONTROL SYSTEM TIMING
 (Typical cooling cycle - Cool Mode Only... No Reverse Cycle)

- Notes:
1. The lead compressor is automatically rotated. For illustrative purposes, this graph assumes the lead compressor is #1.
 2. A three stage compressor system is assumed in this example cycle.
 3. The sea water pump (PW) is programmed for 'Cycle with Compressor' in this example.
 4. The Un-Loader valves are optional and are used to reduce starting in-rush current.

fig 5: System Timing for Chill Cycle Cooling

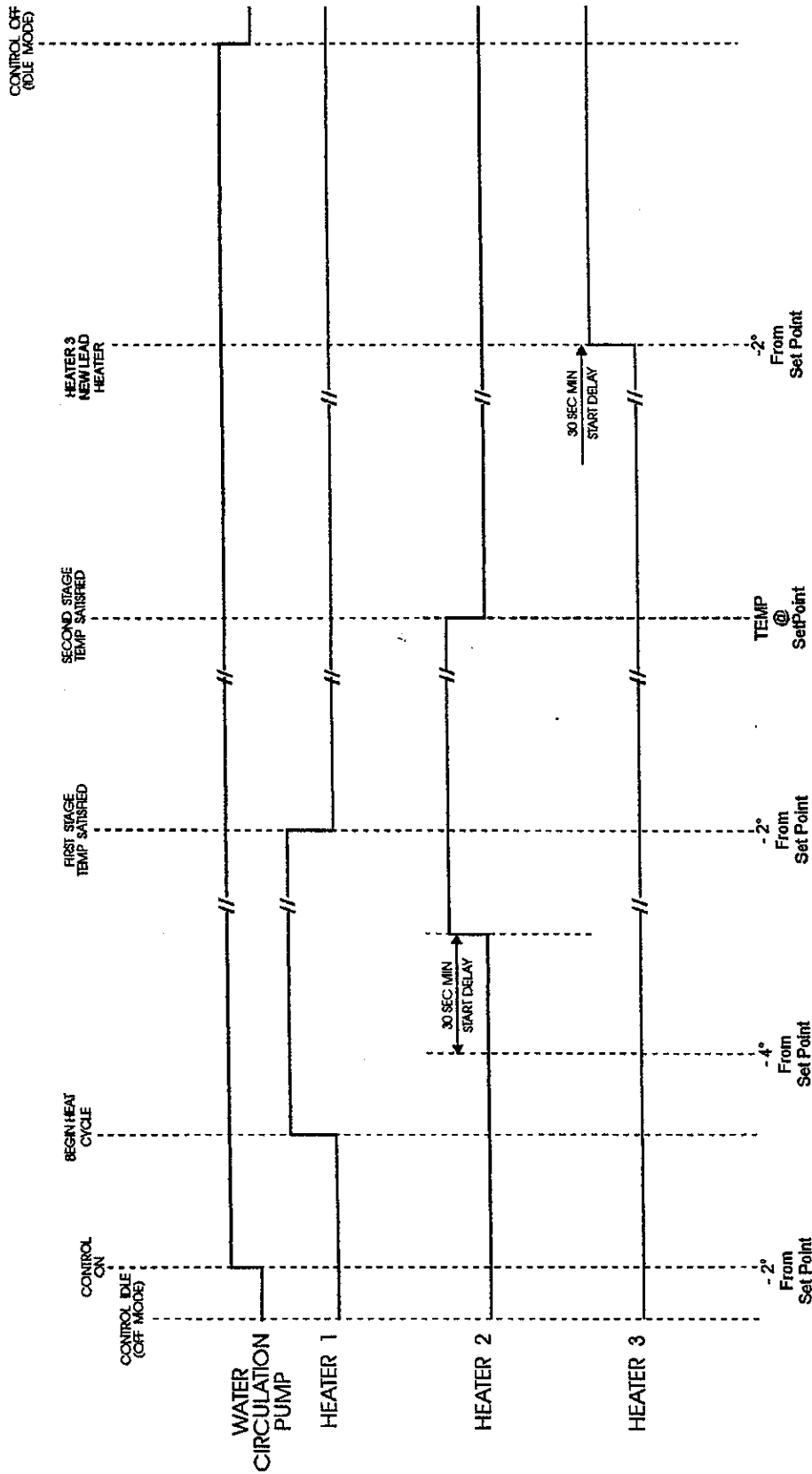

Figure 3: HYDRO-MATIC CONTROL SYSTEM TIMING
(Typical Heating cycle - Chill Cycle Mode)

- Notes:
1. The lead heater is automatically rotated. For illustrative purposes, this graph assumes the lead heater is #1.
 2. A three stage heater system is assumed in this example cycle.
 3. No sea water pump operation when electric heat is operating.

fig 6: System Timing for Chill Cycle Heating

FAULT DETECTION AND FAILSAFE PROTOCOLS

Pressure and temperature sensors are monitored for abnormal indications, which may then be flagged as faults.

Failsafe Protection

There are three levels of reaction to faults detected by the Hydro-matic:

Level 0 is the lowest level of protection; non "fatal" faults will be suppressed, and there will be no indications to the user that a fault occurred.

Level 1 is the intermediate level of protection; non "fatal" faults will be flagged and displayed, but no other actions will be taken.

Level 2 is the maximum level of protection provided; the hydromatic will indicate when a fault has occurred and will also shut down system components as required.

Fatal faults are conditions that, if they occur, could damage the control and/or system components. For this reason, reaction to these faults is mandatory and are not part of a limited failsafe scheme.

The following table lists the faults that can be detected and the action taken by the Hydro-matic for all three protection levels:

Detected Fault	Fault Code Code	Action Taken by Hydro-matic Action Taken by Hydro-matic	Failsafe Action Taken Failsafe			Service LED			Error Type
			LVL 0	LVL 1	LVL 2	LVL 0	LVL 1	LVL 2	
OUTLET TEMPERATURE	---	NO ACTION TAKEN	NO	NO	NO	OFF	ON	ON	Non-Fatal
COMPRESSOR HIGH WATER TEMPERATURE (physical sensor fault)	CS(1-4))	COMPRESSOR OFF LINE	NO	NO	YES	OFF	ON	ON	Non-Fatal
COMPRESSOR HIGH WATER TEMPERATURE (limit exceeded fault)	CL(1-4)	COMPRESSOR OFF LINE	NO	NO	YES	OFF	ON	ON	Non-Fatal
INLET TEMPERATURE	---	HEATING/COOLING OFF	YES	YES	YES	ON	ON	ON	Fatal
HIGH FREON PRESSURE	HP(1-4)	COMPRESSOR OFF LINE	YES	YES	YES	ON	ON	ON	Fatal
LOW FREON PRESSURE	LP(1-4)	COMPRESSOR OFF LINE	YES	YES	YES	ON	ON	ON	Fatal
LOW OIL PRESSURE *	OP(1-4)	COMPRESSOR OFF LINE	YES	YES	YES	ON	ON	ON	Fatal
LOW VOLTAGE **	A - C	HEATING/COOLING OFF	YES	YES	YES	ON	ON	ON	Fatal

* Note: On units equipped with variable frequency drives (VFD's) an OP fault is an indication of a drive fault.

FAULT DETECTION AND FAILSAFE PROTOCOLS



When a fault is detected, it is reported and acted upon according to the programmed failsafe level (P-8). If the **service LED** is turned on, the **Outlet Temp** display will also provide a flashing fault code. If the Hydro-matic is required to take a compressor off line because of the fault, the LED for that compressor will flash, indicating that an error has been detected.

If it is desired that the flashing fault code be removed from the display, then press the **Select** button. This **does not**, however clear the fault or return the compressor to on line status.

Inlet temperature and Low Voltage faults will result in the complete shutdown of the system. The system will remain shut down until the faults are cleared.

A compressor pressure fault (High Freon or Low Oil) is defined to be an open contact detected on a pressure sensor for a compressor that has been running at least 15 seconds. A Low Freon Pressure fault is defined to be an open contact on a pressure sensor for a compressor that has been running at least 4 minutes.

If the compressors are shut down but not taken off line when the fault occurs, the **Service LED** and fault code will be displayed for approximately 1 second.



Compressor Lockout occurs when three (3) successive pressure faults are detected during one heating or cooling cycle. At this point, the failed compressor(s) is (are) taken off line. To clear the fault and return the compressor(s) back to on line status *after the problem has been checked and corrected*, the control must be turned off (**ON/OFF** button), and then back on.

LINE VOLTAGE FAILSAFE PROTOCOLS

Line Voltage

The Hydro-matic monitors the input line voltage. This is used to protect the chiller system hardware and the Hydro-matic.



A-C will be displayed in the **Outlet Temp** display if the line voltage drops below the level set with the **Line Voltage Limit** option (P-13) during normal operation of the Hydro-matic. All outputs will be shut down until the voltage rises above the programmed limit.

If the Hydro-matic is connected to improper voltage during initial power-up, the following messages will be displayed:

A-C



A **Low Power on AC Line Fault (AC)** will occur if a system configured for 220V is connected to a 110V supply. "A-C" will flash in the **outlet temp** display and the Hydro-matic will shut down all outputs.

HPF



A **High Power Fault (HPF)** will occur if a system configured for 110V is connected to a 220V supply. "HPF" will be alternating between both the **Inlet and Outlet Temp** displays and the Hydro-matic will shut down all outputs.



IMPORTANT: If this condition has occurred, power must be removed immediately to avoid damage to the Hydromatic and associated hardware.

Note: On units equipped with variable frequency drives (VFD's) an OP fault is an indication of a drive fault.

HYDROMATIC CHILLER CONTROL SETTINGS



PROGRAM NUMBER	PARAMETER		SET VALUE	RANGE	
				MINIMUM	MAXIMUM
P-1	HEAT SET POINT			95° F 35° C	118° F 48° C
P-2	COOL SET POINT			46° F 8° C	58° F 14° C
P-3	HEAT STAGING TEMPERATURE			1° F 1° C	6° F 3° C
P-4	COOL STAGING TEMPERATURE			1° F 1° C	6° F 3° C
P-5	STAGING TIME DELAY			30 secs	200 secs
P-6	SERVICE SENSOR HIGH TEMPERATURE LIMIT			120° F 49° C	145° F 63° C
P-7	SERVICE SENSOR LOW TEMPERATURE LIMIT			25° F -4° C	45° F 7° C
P-8	FAILSAFE LEVEL	0 = minimum 1 = display only 2 = maximum failsafe		0	2
P-9	SEAWATER PUMP OPERATION	0 = continuous 1 = cycle w/ compressor		0	1 ✓
P-10	NUMBER OF HEATERS EQUIPPED *			0 (1)	4 (2)
P-11	NUMBER OF COMPRESSORS EQUIPPED *			1	4 (2)
P-12	SENSORS EQUIPPED	see program description for details		0	7
P-13	LINE VOLTAGE LIMIT	110 v System		80 v	100v
		220 v System		180 v	200 v
P-14	TEMPERATURE UNITS	0 = ° Fahrenheit		0	1
		1 = ° Celsius			

* NUMBERS IN PARENTHESES INDICATE 2 STATION HYDROMATIC SETTINGS AND RANGES